

Module Manual for LX Series Programmable Logic Controllers

Table of Contents

Chapter 1	Foreword.....	1
Chapter 2	Document Guide	3
Chapter 3	Revision History.....	5
Chapter 4	Module Overview.....	6
Chapter 5	Controller	14

Chapter 6	Power module.....	87
------------------	--------------------------	-----------

Chapter 7	Interface Module.....	105
-----------	-----------------------	-----

Chapter 8	Communication Module	125
-----------	----------------------------	-----

Chapter 9	HUB Module.....	153
-----------	-----------------	-----

Chapter 13	Installation Guide	282
-------------------	---------------------------------	------------

Chapter 14	Module accessory	305
-------------------	-------------------------------	------------

Chapter 1 Foreword

1.1 Purpose

1.2 Object

1.3 Target Products

1.4 Statement of Use

1.5 Safety Precautions

1.5.1 Safety Statement

1.5.2 Warning









Chapter 2 Document Guide

2.1 Related Manuals

Manual Name	Purpose	Content

2.2 Usage Convention

-

2.3 How to Get the Manual

Chapter 3 Revision History

Version	Revision
---------	----------

Chapter 4 Module Overview

4.1 Hardware Composition

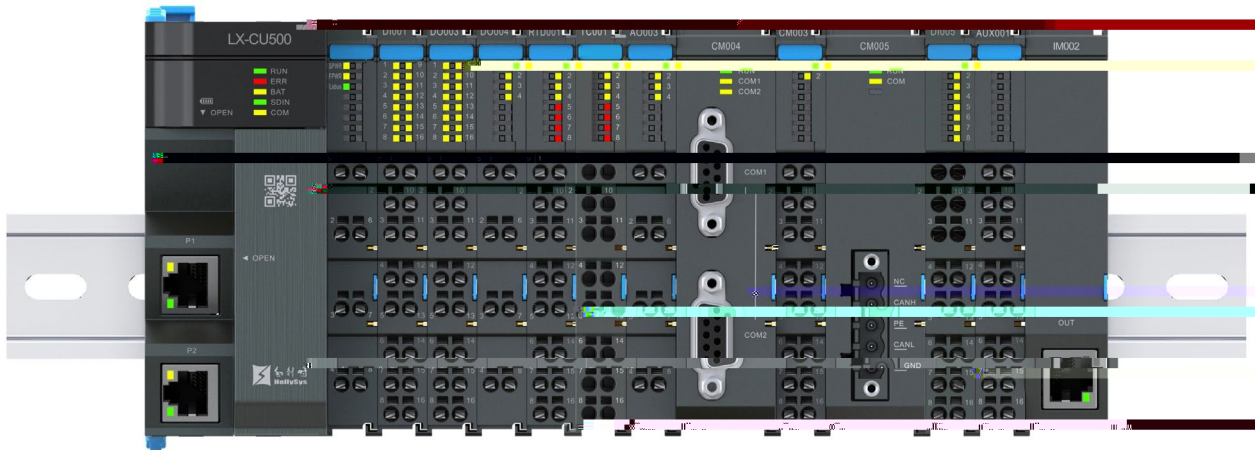

-
-
-

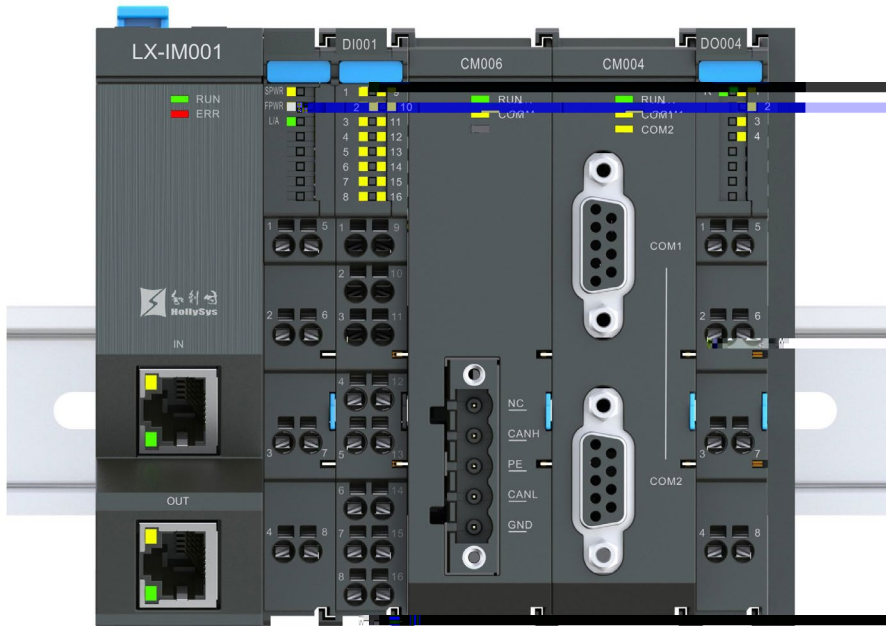

4.2 Network Configuration

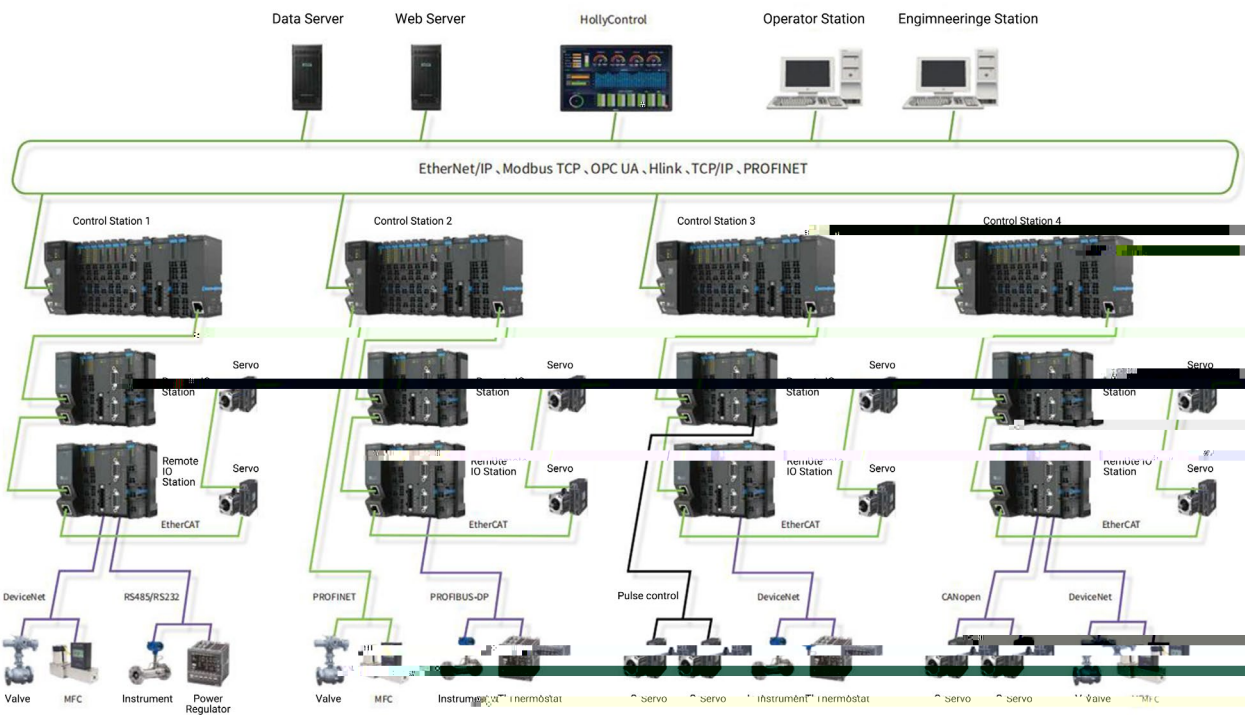





4.3 Product List

CPU Module					
Type	Module Name	Specifications		Certification	Dimensions W×H×D (mm)

Position Interface Module						
						
Pulse Output Module						
						
Encoder Module						



						
Voltage Distribution Module						
						

Analog Output Module									
					250μs/point				
						1K			
					100μs/point		600 1K		
Coupler Module									
									
Communication Module									
									

Power Supply Module						
						
HUB Module						

						

Chapter 5 Controller

5.1 Controller First Power On Configuration Guidance

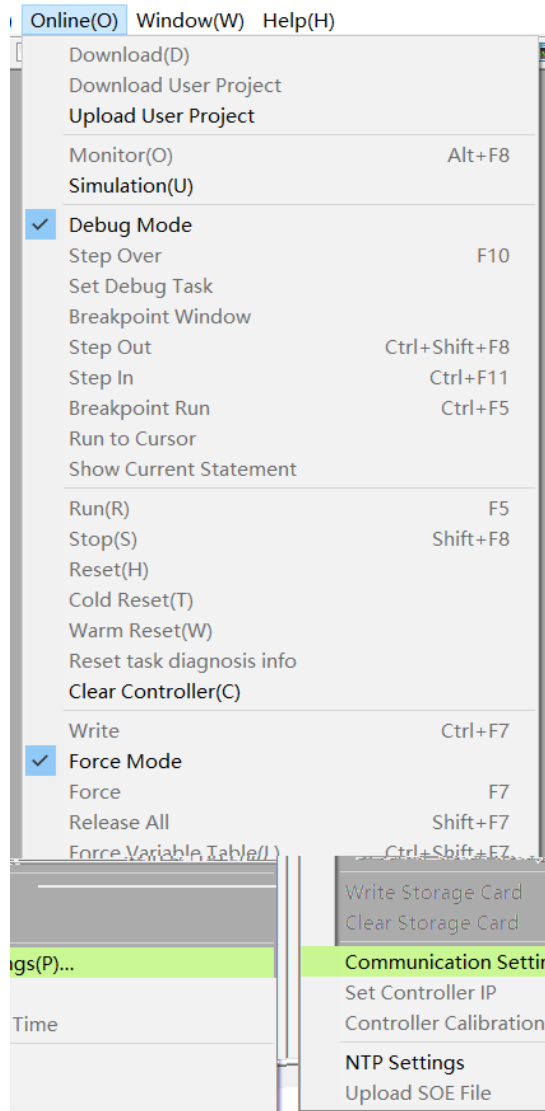

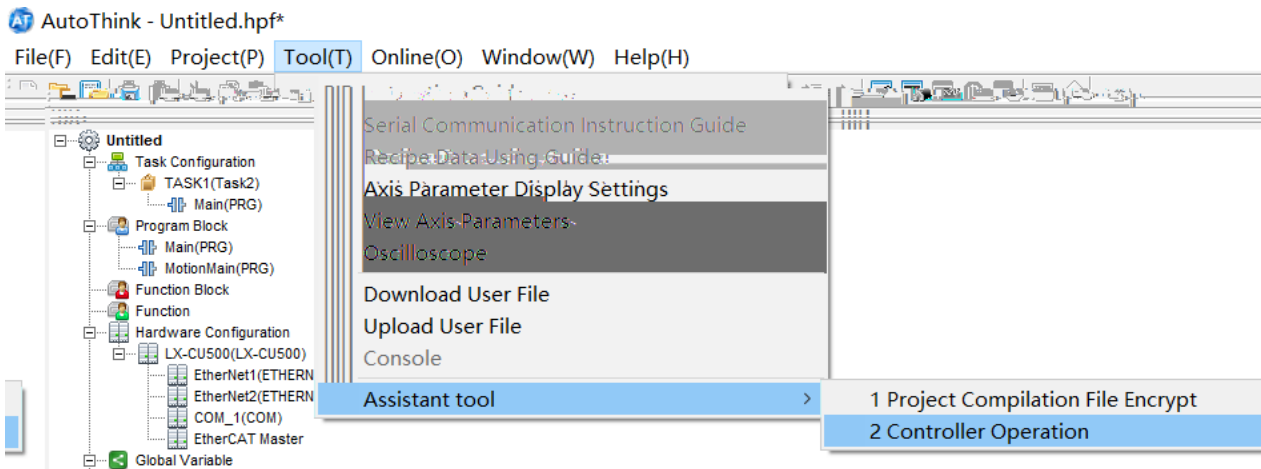
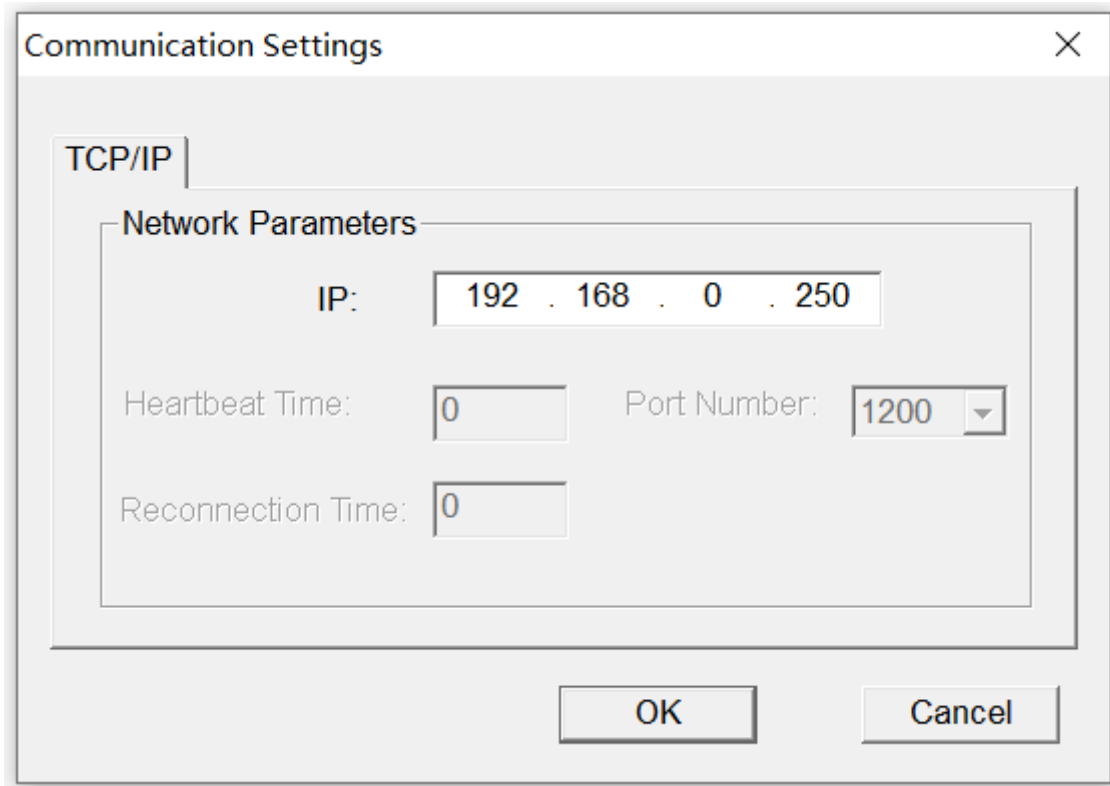

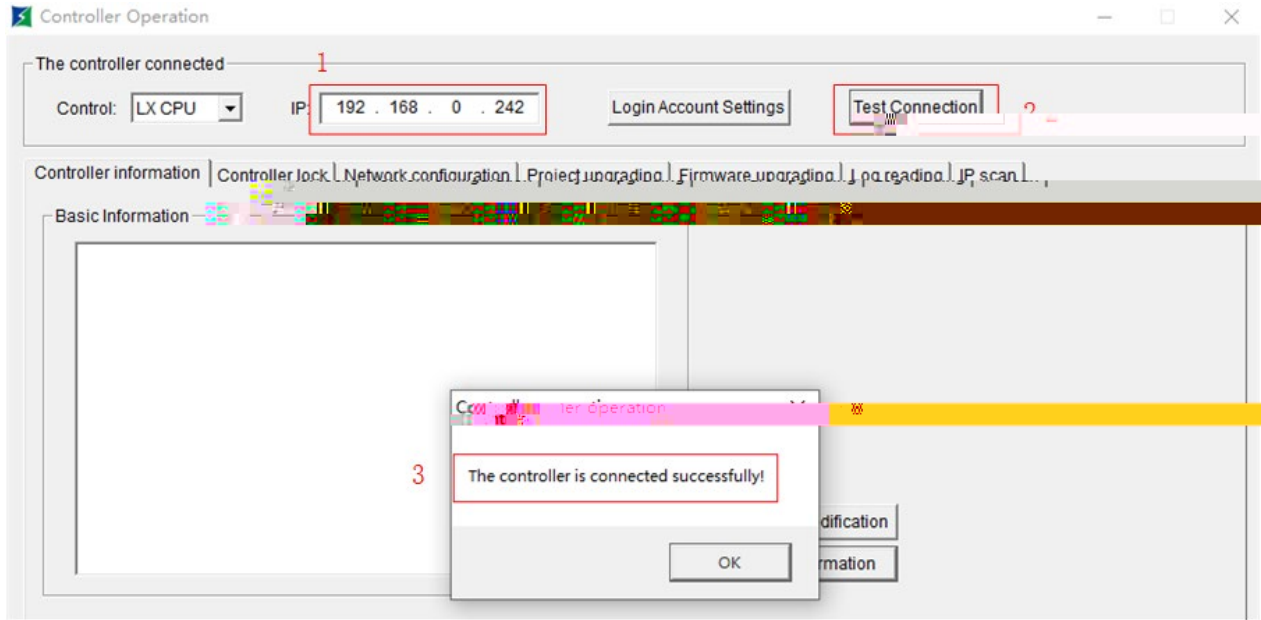

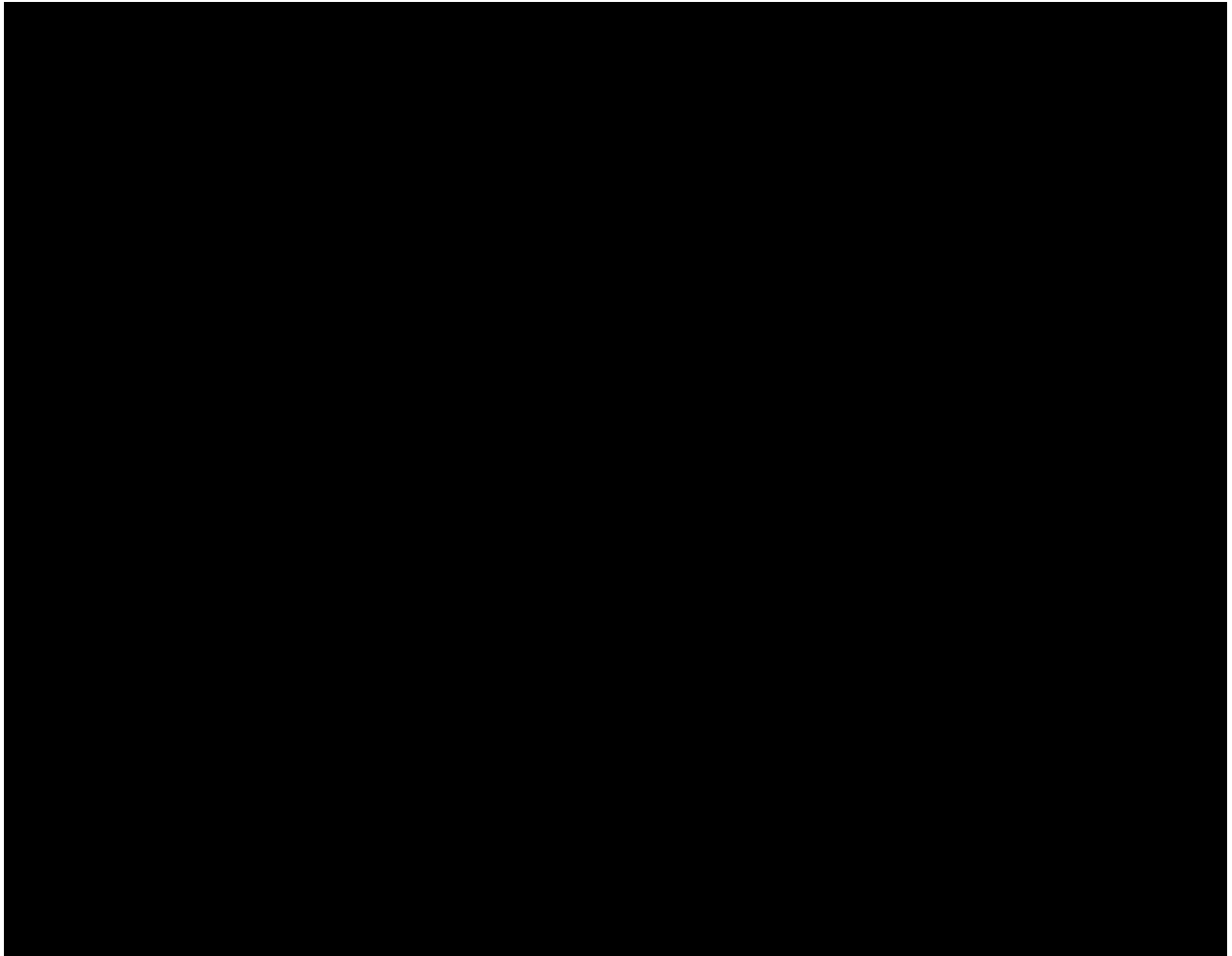

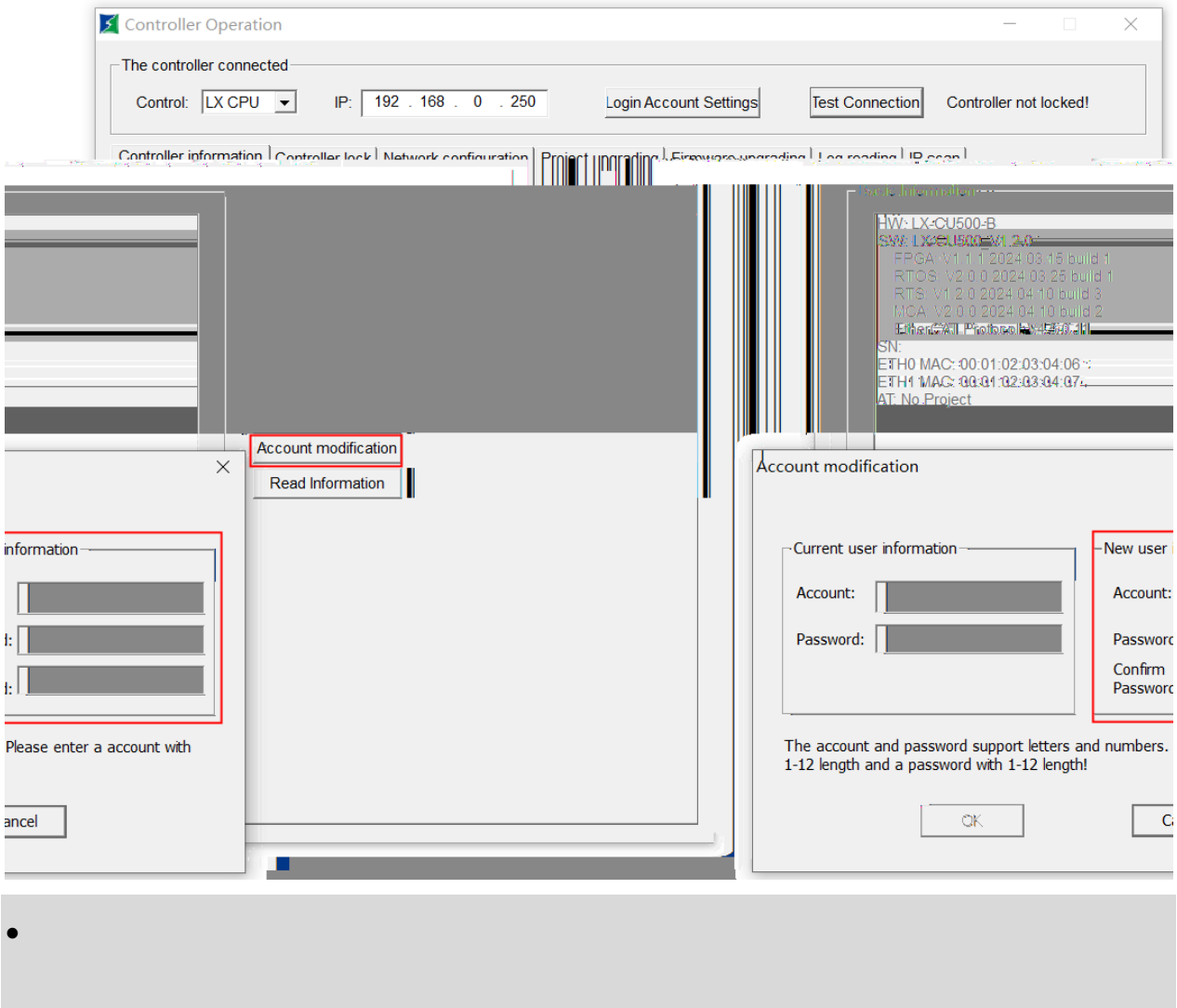

5.3 LX-CU500 CPU Module

5.3.1 Product Overview

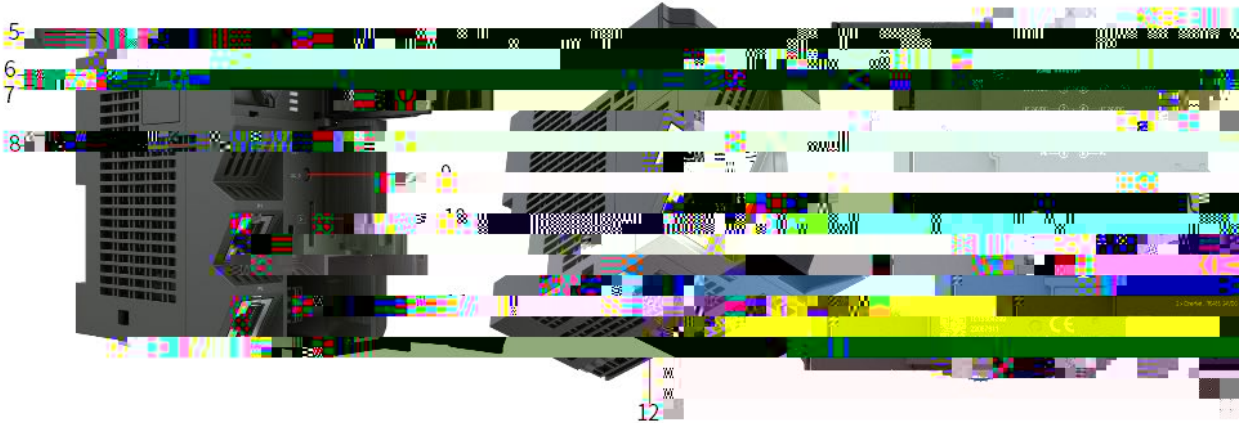
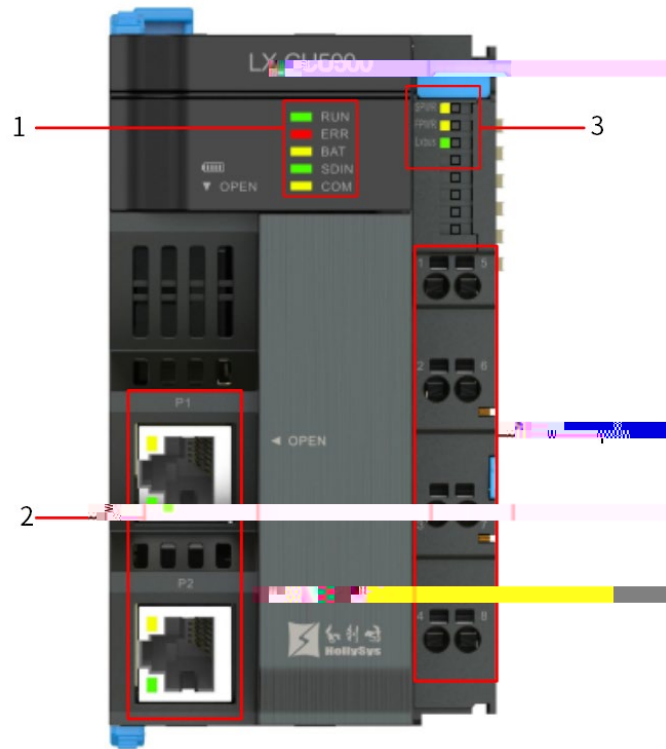

Block diagram

Module part description table

S/N	Component Name	Instructions
		<p style="text-align: center;"> <i>Programmable Logic Controllers></i> <i>LX Programming Manual for LX</i> </p>

5.3.5 Description of Wiring Terminal

5.3.5.1 Power Wiring

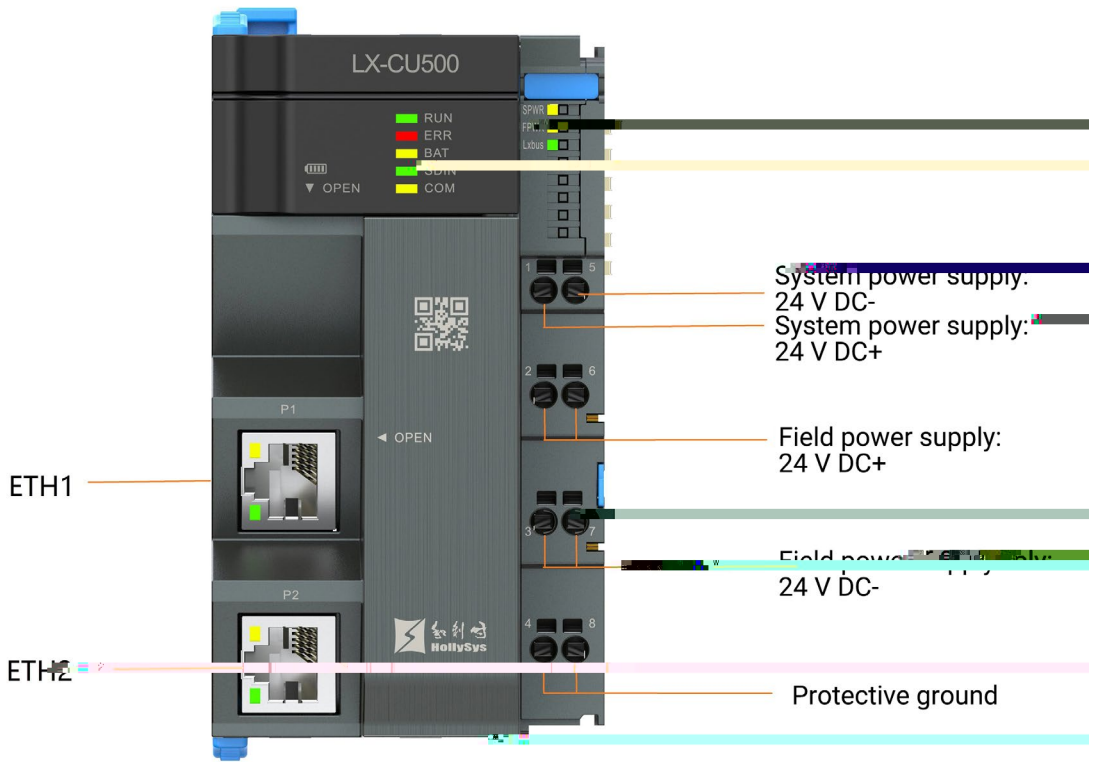

The definition of power terminals

Left Terminal Pin	Description of Signals	Right Terminal Pin	Description of Signals

-

5.3.5.2 RS-485 wiring



The definition of RS-485 terminals

Terminal Identification	Description of Signals	Description

-

5.3.6 Battery

-

5.3.6.1 Models and specifications

Model	Specifications

5.3.6.2 Purpose

5.3.7 SD Memory Card

5.3.7.1 Models and specifications

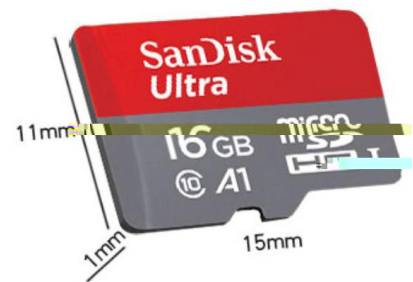

5.3.7.2 Purpose

5.3.7.3 SD card button

5.3.8 Engineering configuration

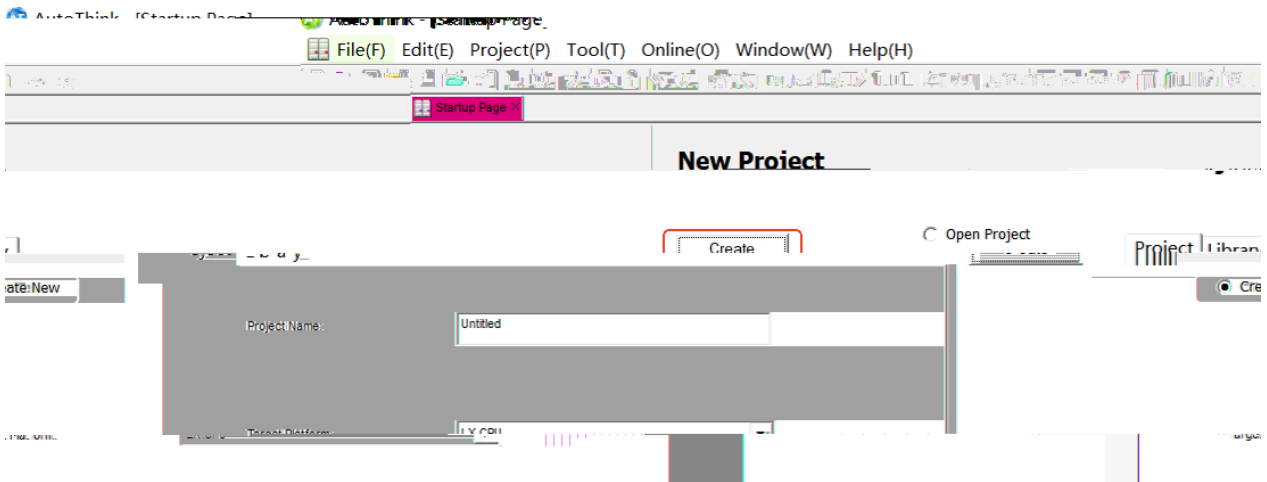

(a)

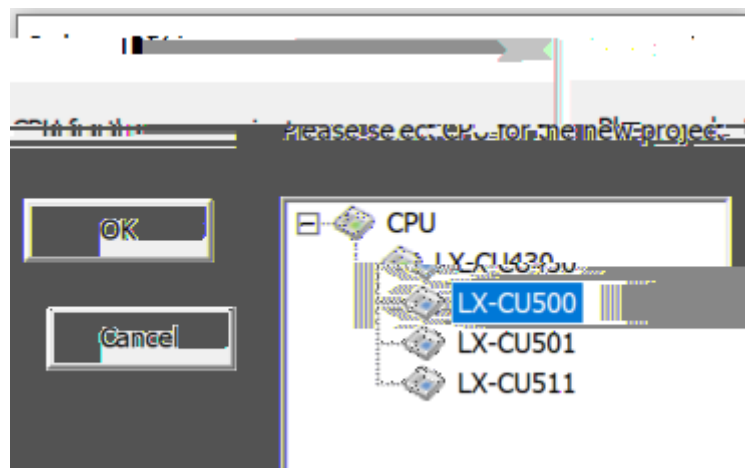

(b)

Add CPU

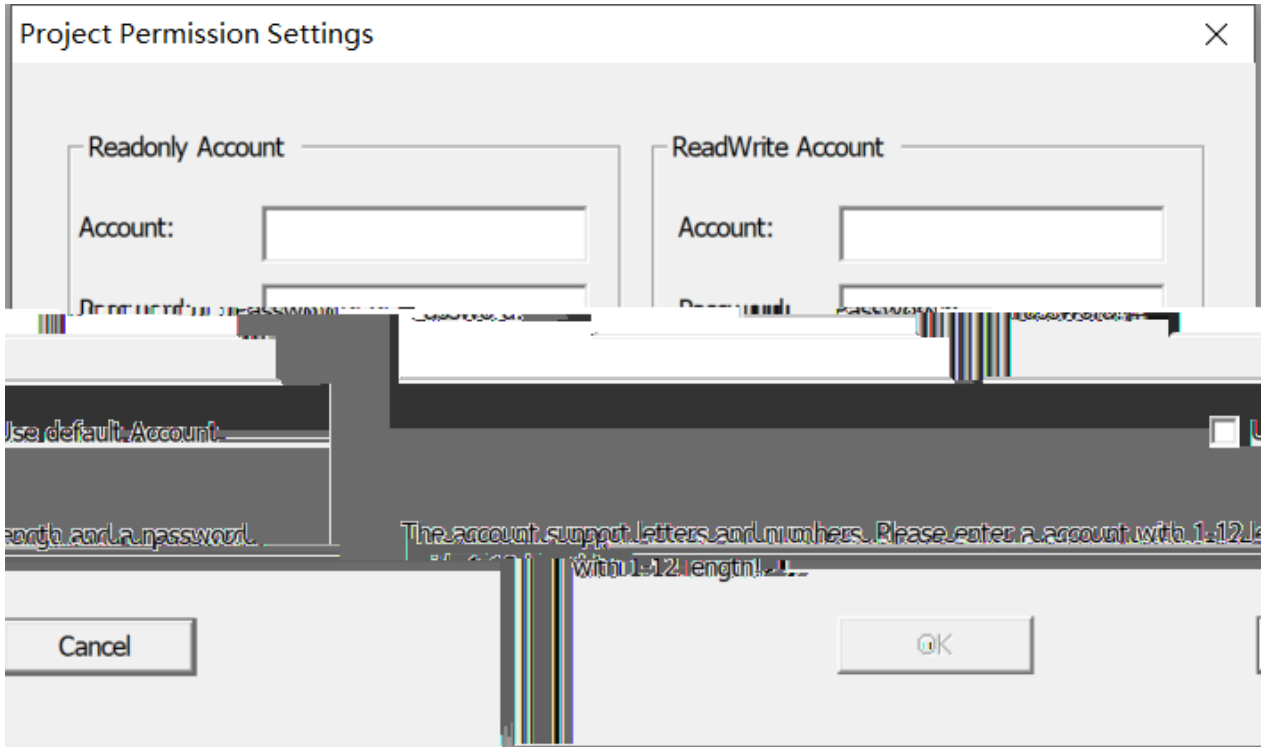

- *LX Programming Manual for LX Programmable Logic Controllers*

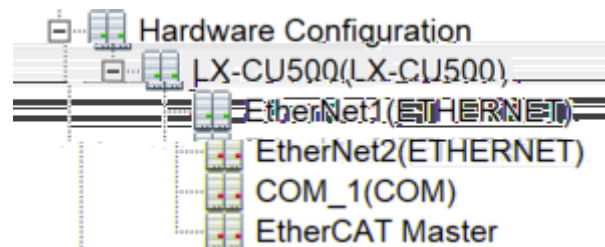

Communication Manual for LX Programmable Logic Controllers

5.3.9 Diagnostic Information

Type	Parameters
------	------------

5.4 LX-CU501 CPU Module

5.4.1 Product Overview

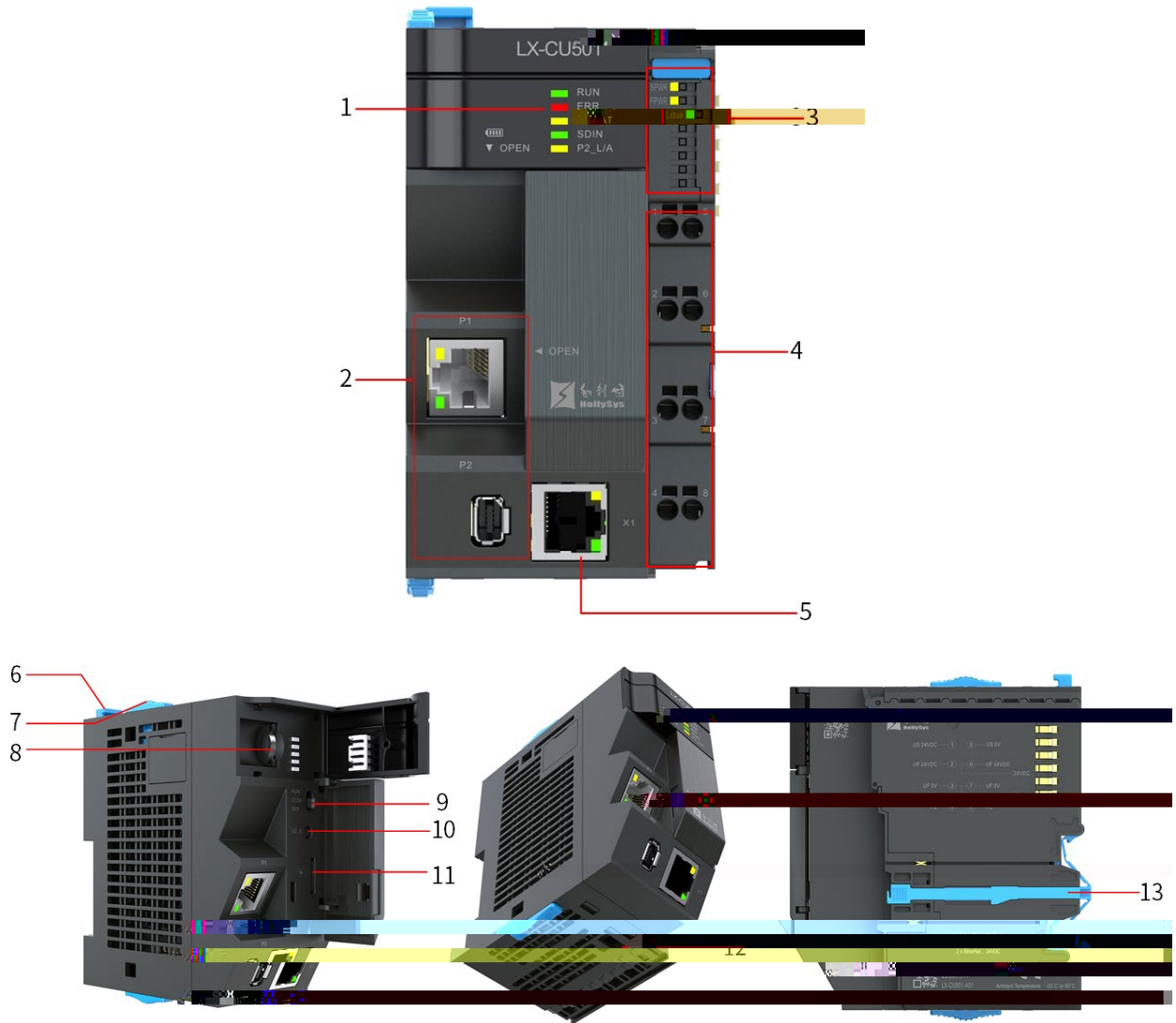

Block diagram

Module part description table

S/N	Component Name	Instructions

		<i>LX Programming Manual for LX</i>
		<i>Programmable Logic Controllers></i>

Item	Specifications
Ethernet Bus 1 (P1\ P2 northbound network)	

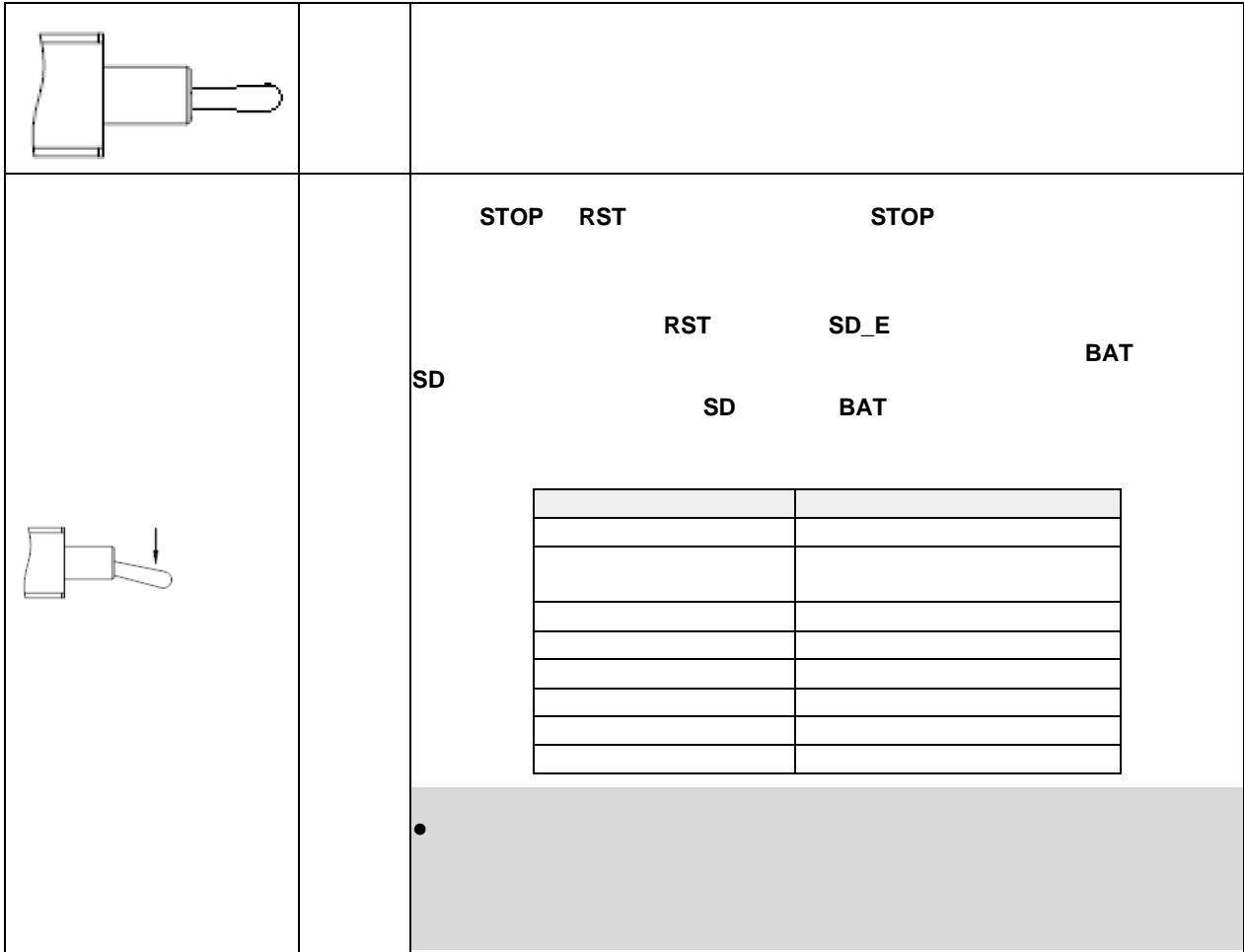

5.4.4 Status Indicator

Name	Color	Meaning

5.4.5 Description of Wiring Terminal

5.4.5.1 Power Wiring

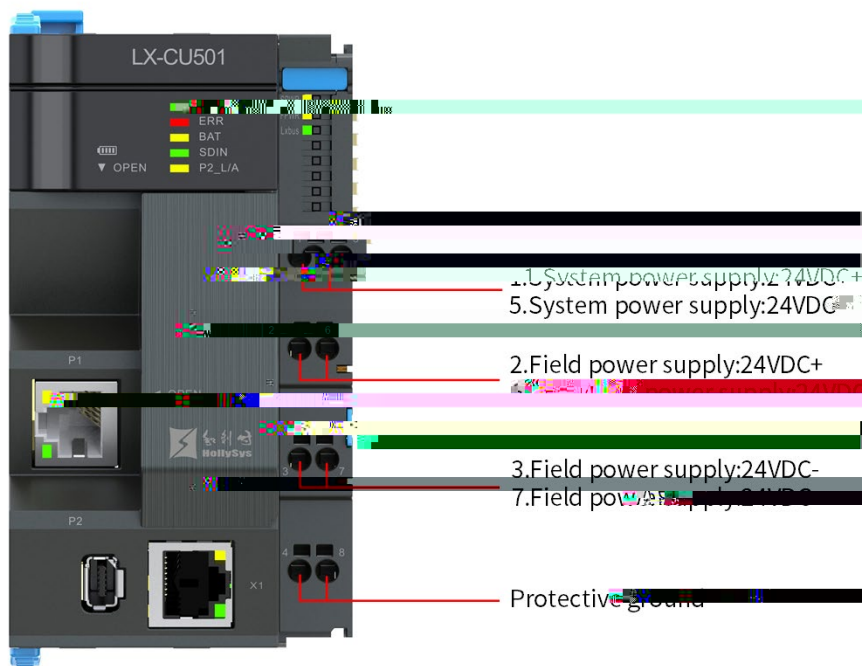

The definition of power terminals

Left Terminal Pin	Description of Signals	Right Terminal Pin	Description of Signals

•

5.4.6 Battery

-

5.4.6.1 Models and specifications

Model	Specifications

5.4.6.2 Purpose

5.4.7 SD Memory Card

5.4.7.1 Models and specifications

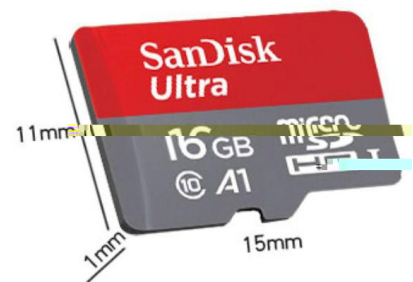

5.4.7.2 Purpose

5.4.7.3 SD card button

5.4.8 Engineering configuration

5.4.9 Diagnostic Information

Type	Parameters	Fault Name	Diagnostic Information

5.5 LX-CU510 Enhanced high-performance controller

5.5.1 Product Overview

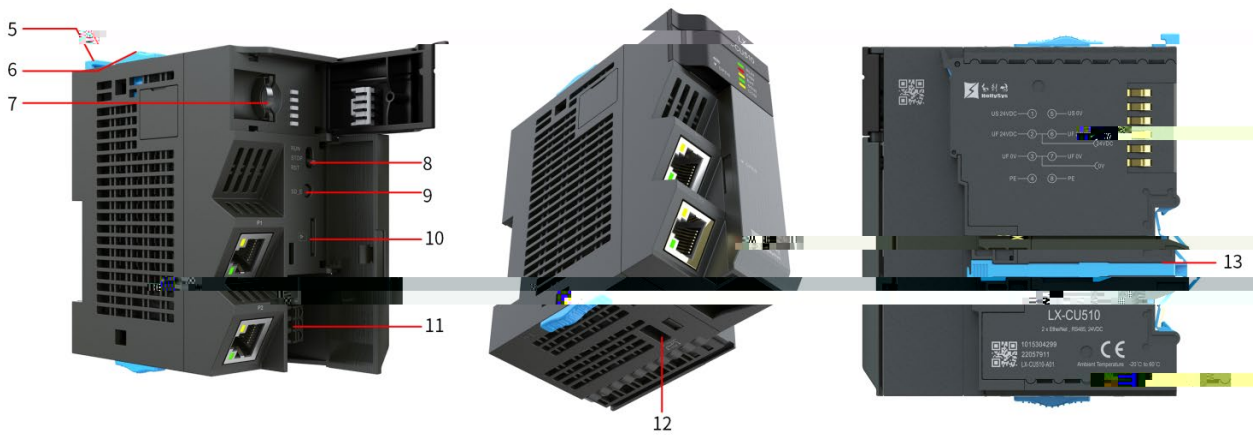

Block diagram

Module part description table

S/N	Component Name	Instructions
-----	----------------	--------------

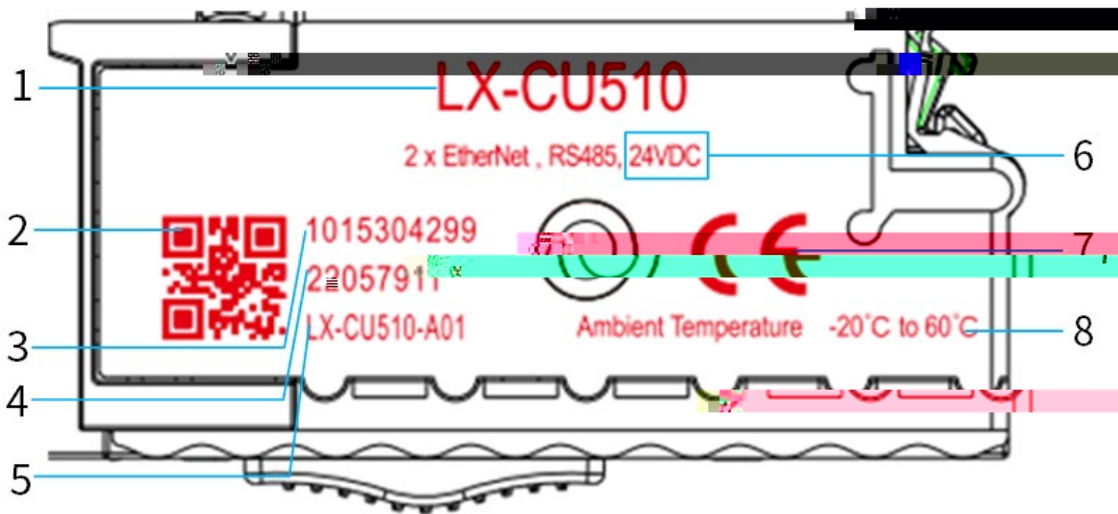

LX-CU510 nameplate sketch
The nameplate information described

S/N	Name	Description

5.5.3 Operating Mode Switch

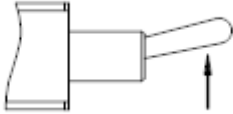
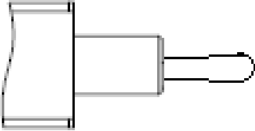
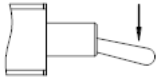
Name	Meaning	Operating Instruction																
																		
																		
		<p>STOP RST STOP</p> <p>RST SD_E BAT</p> <p>SD SD BAT</p> <table border="1" style="margin-left: auto; margin-right: auto;"> <tr><td> </td><td> </td></tr> <tr><td> </td><td> </td></tr> <tr><td> </td><td> </td></tr> <tr><td> </td><td> </td></tr> <tr><td> </td><td> </td></tr> <tr><td> </td><td> </td></tr> <tr><td> </td><td> </td></tr> <tr><td> </td><td> </td></tr> </table> <p>•</p>																

5.5.4 Status Indicator

The table of indicator statuses

Name	Color	Meaning

5.5.5 Description of Wiring Terminal

5.5.5.1 Power Wiring



The definition of power terminals

Left Terminal Pin	Description of Signals	Right Terminal Pin	Description of Signals

-

5.5.5.2 RS-485 wiring



The definition of RS-485 terminals

Terminal Identification	Description of Signals	Description

-

5.5.6 Battery

-

5.5.6.1 Models and specifications

Model	Specifications

5.5.6.2 Purpose

5.5.7 SD Memory Card

5.5.7.1 Models and specifications

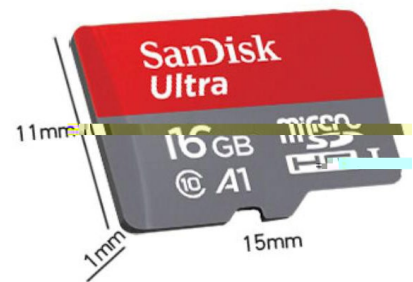

5.5.7.2 Purpose

5.5.7.3 SD card button

5.5.8 Engineering configuration

5.5.9 Diagnostic Information

Type	Parameters	Fault Name	Diagnostic Information

5.6 LX-CU511 High-performance controller module for ring network

5.6.1 Product Overview

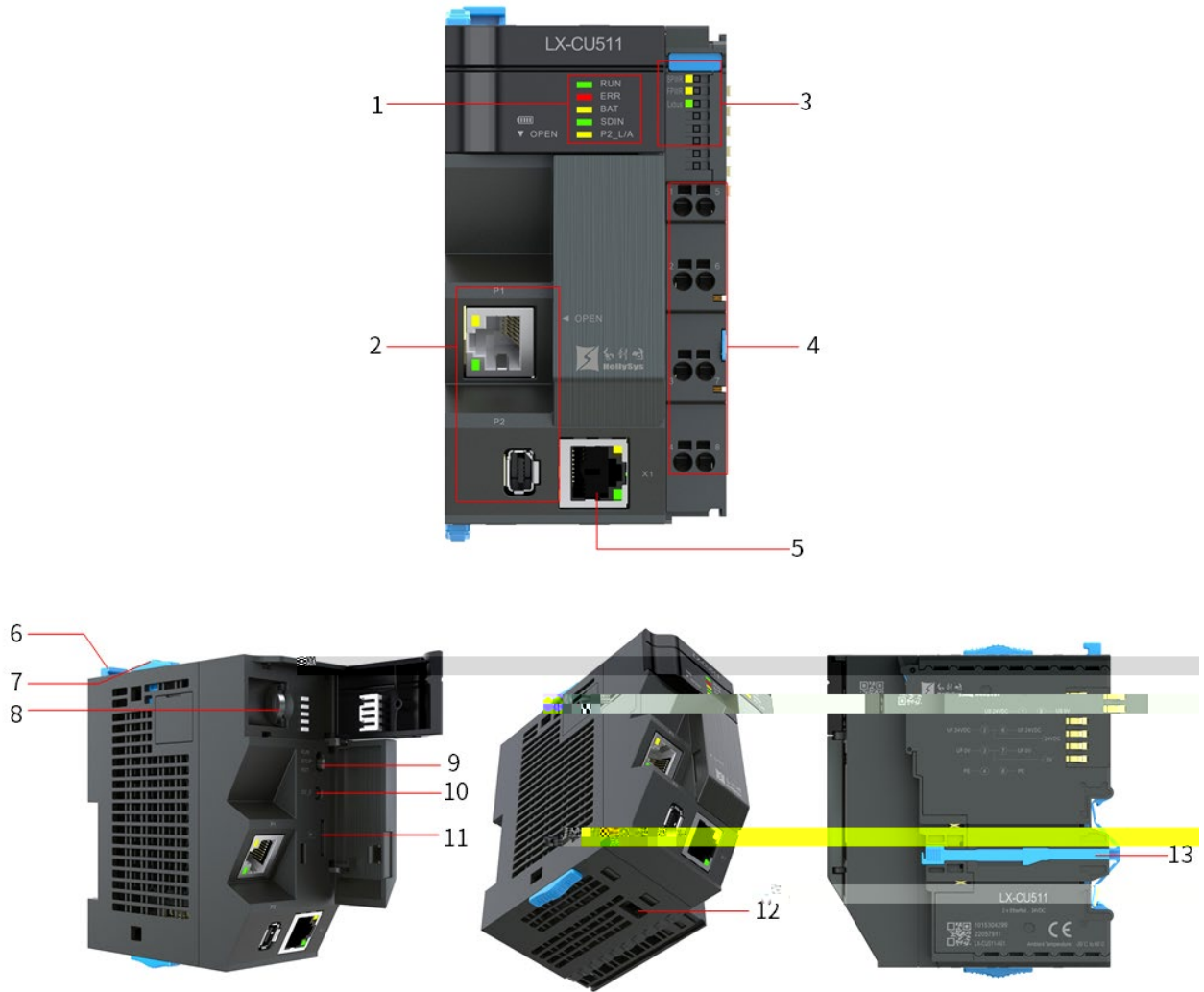

Block diagram

Module part description table

S/N	Component Name	Instructions

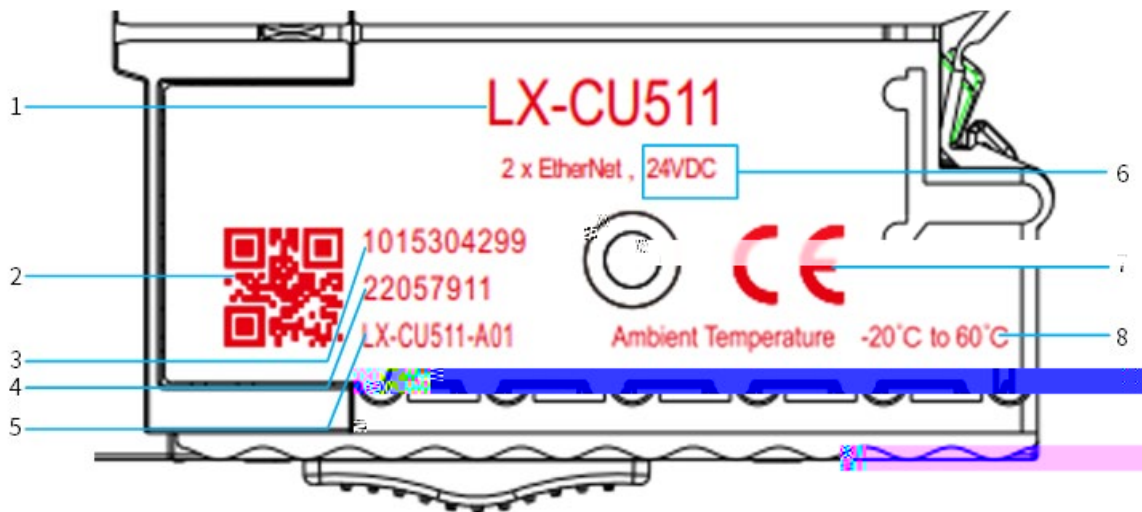

LX-CU511 nameplate sketch

The nameplate information described

S/N	Name	Description

5.6.2 Technical Indicators

Item	Specifications
	±60 seconds/month, timing supported

	Virtual axis bus axis 64 axis

Item	Specifications
	Minimum support of 500μs

5.6.3 Operating Mode Switch

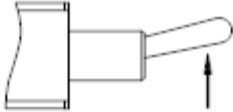
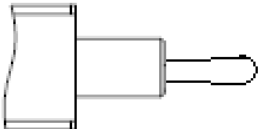
Name	Meaning	Operating Instruction
		
		

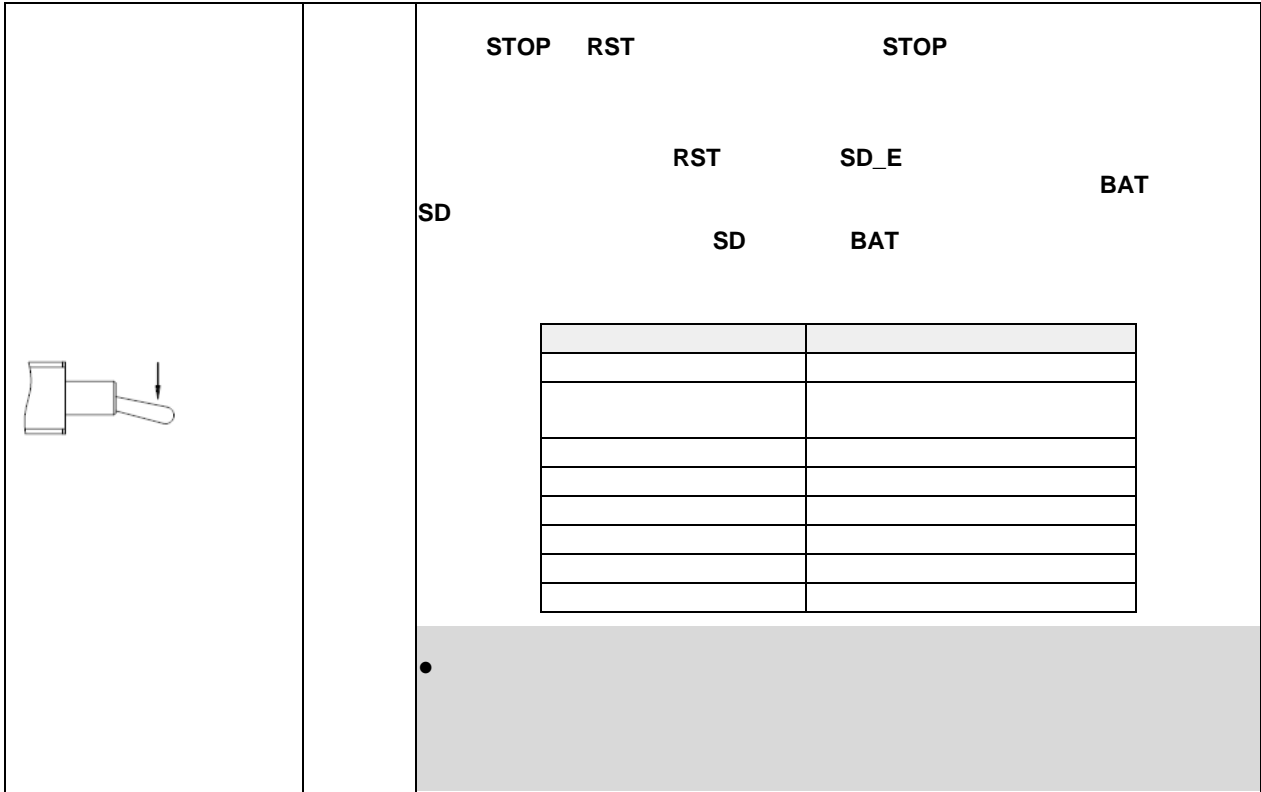

5.6.4 Status Indicator

Color	Name	Meaning

5.6.5 Description of Wiring Terminal

5.6.5.1 Power Wiring

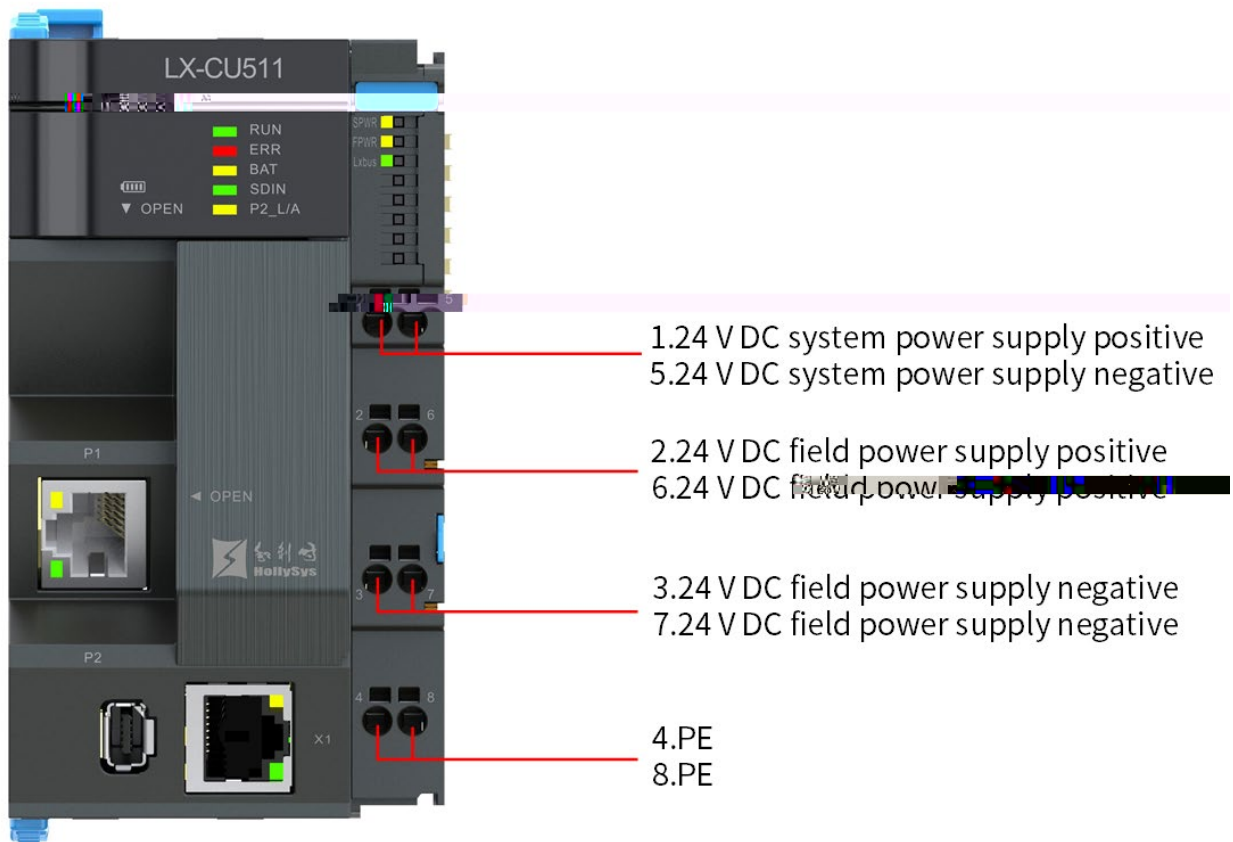

The definition of power terminals

Left Terminal Pin	Description of Signals	Right Terminal Pin	Description of Signals

5.6.6 Battery

5.6.6.1 Models and specifications

Model	Specifications

5.6.6.2 Purpose

5.6.7.3 SD card button

5.6.8 Engineering configuration

5.6.9 Diagnostic Information

Type	Parameters	Fault Name	Diagnostic Information

5.7 LX-CU430 Basic type high-performance controller module

5.7.1 Product Overview

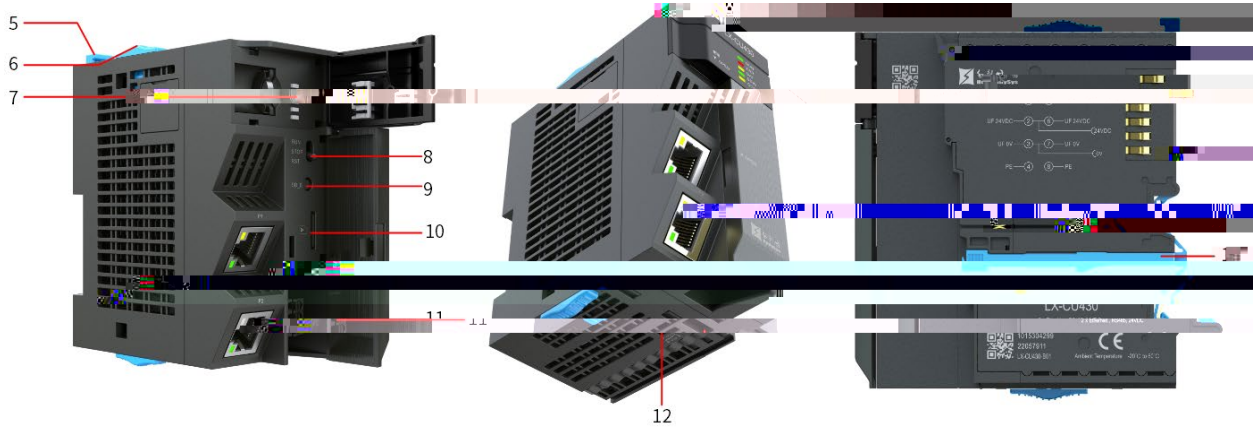
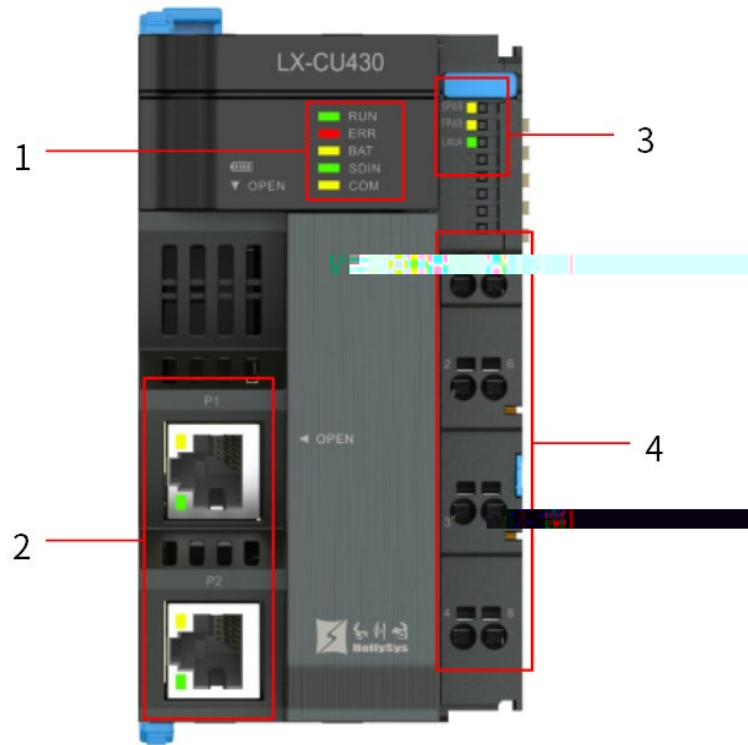

Block diagram

Module part description table

S/N	Component Name	Instructions
		<i>LX Programming Manual for LX</i>
		<i>Programmable Logic Controllers></i>

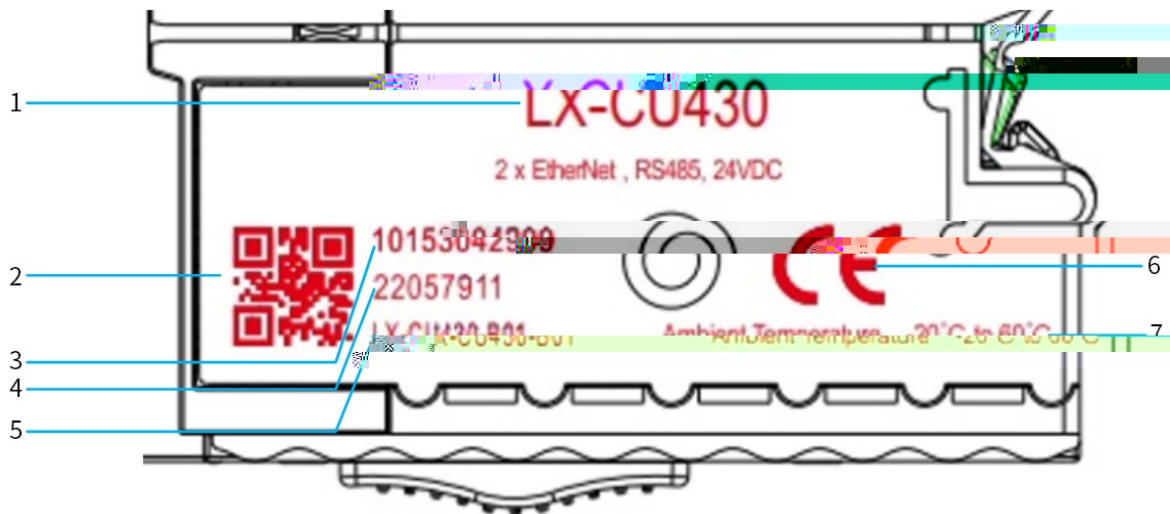

LX-CU430 nameplate sketch
The nameplate information described

S/N	Name	Description
-----	------	-------------

5.7.2 Technical Indicators

Item	Specifications

5.7.5 Description of Wiring Terminal

5.7.5.1 Power Wiring

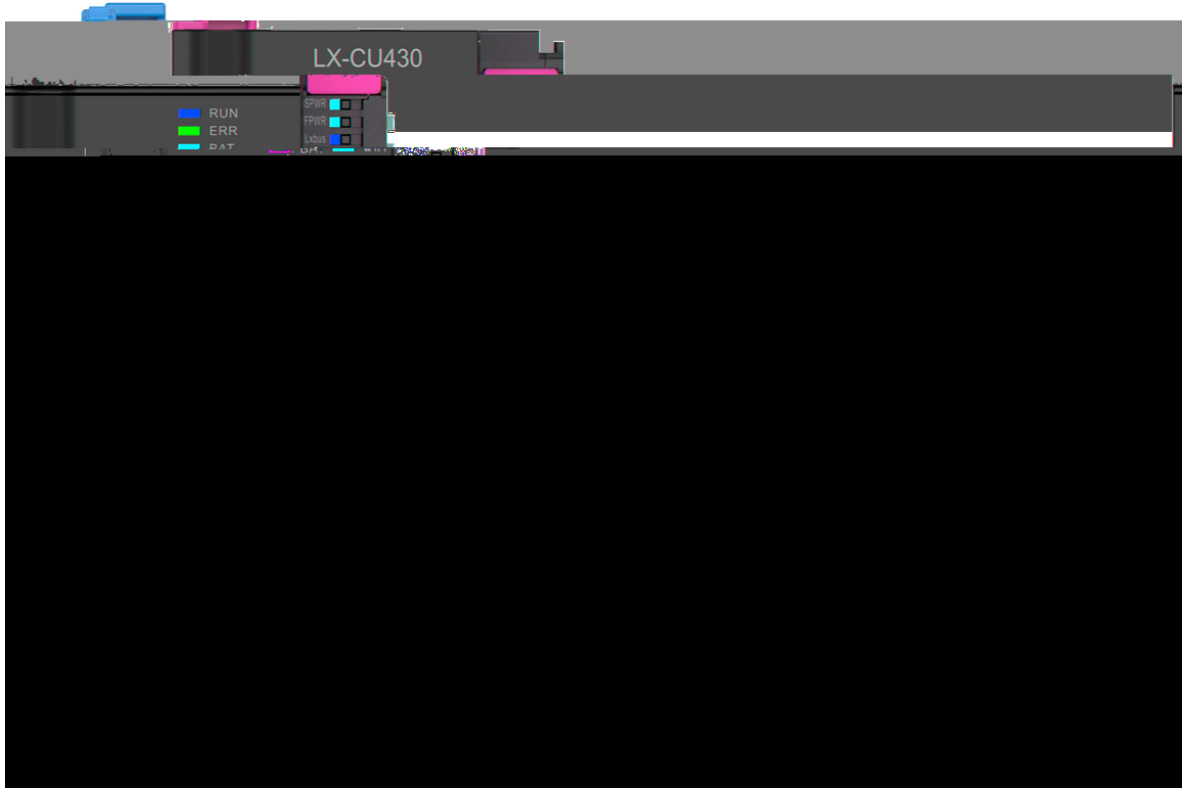

The definition of power terminals

Left Terminal Pin	Description of Signals	Right Terminal Pin	Description of Signals

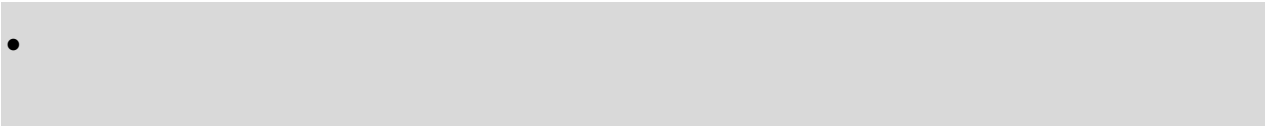

5.7.5.2 RS-485 wiring



The definition of RS-485 terminals

Terminal Identification	Description of Signals	Description



5.7.6 Battery

5.7.7.3 SD card button

5.7.8 Engineering configuration

5.7.9 Diagnostic Information

Type	Parameters	Fault Name	Diagnostic Information

5.8 LX-CM010 Co-processor Module

5.8.1 Product Overview

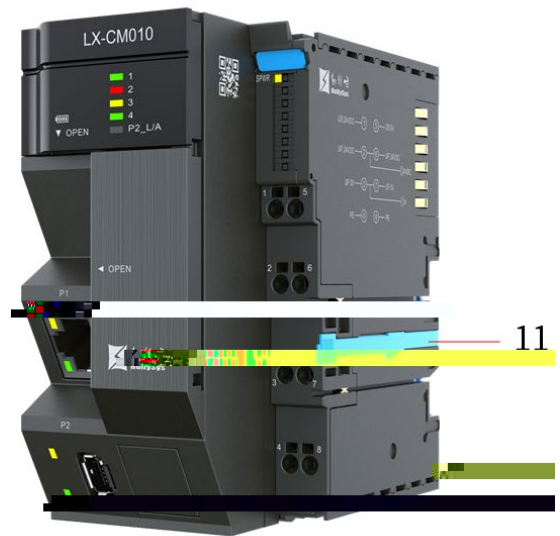
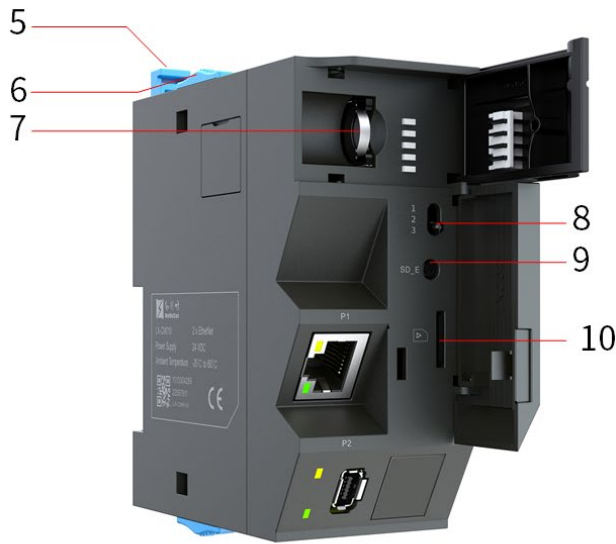
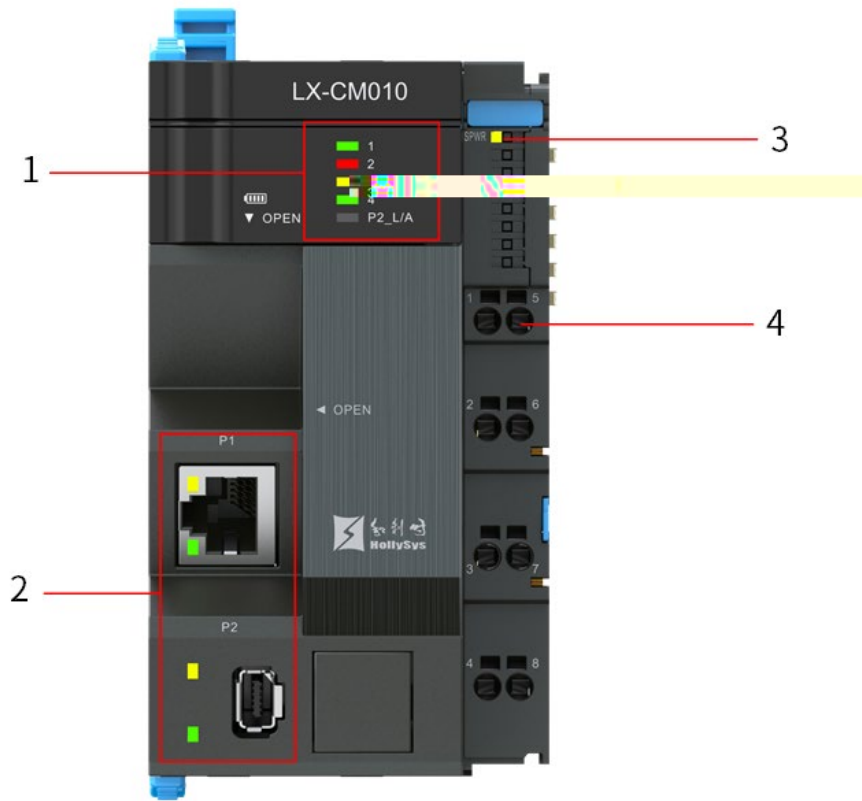

Block diagram
Module part description table

S/N	Component Name	Instructions

5.8.2 Technical Indicators

Item	Specifications
	±60 seconds/month, timing supported

Item	Specifications

Item	Specifications

5.8.3 Operating Mode Switch

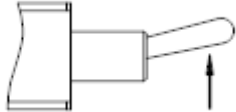
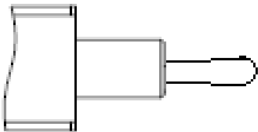
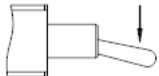
Switch Status	Name	Operating Instruction
		
		
		

5.8.4 Status Indicator

Status indicator description

Color	Name	Meaning

5.8.5 Description of Wiring Terminal



Pin No.	Symbol	Meaning	Pin No.	Symbol	Meaning

5.8.6 Battery

•

5.8.6.1 Models and specifications

Model	Specifications

5.8.6.2 Purpose

5.8.7 SD Memory Card

5.8.7.1 Models and specifications

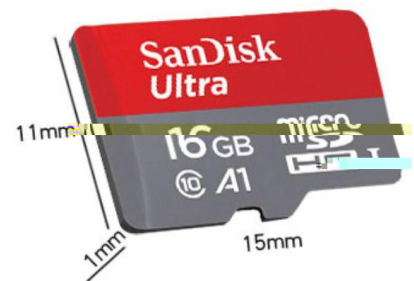

5.8.7.2 Purpose

5.8.7.3 SD card button

Chapter 6 Power module

6.1 Principles for Using Power Modules

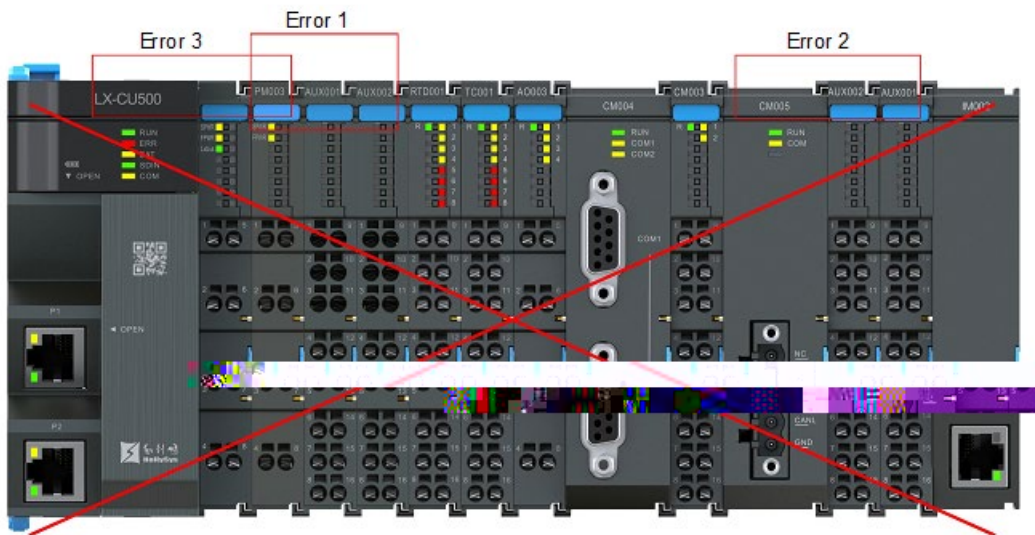

Error demonstration

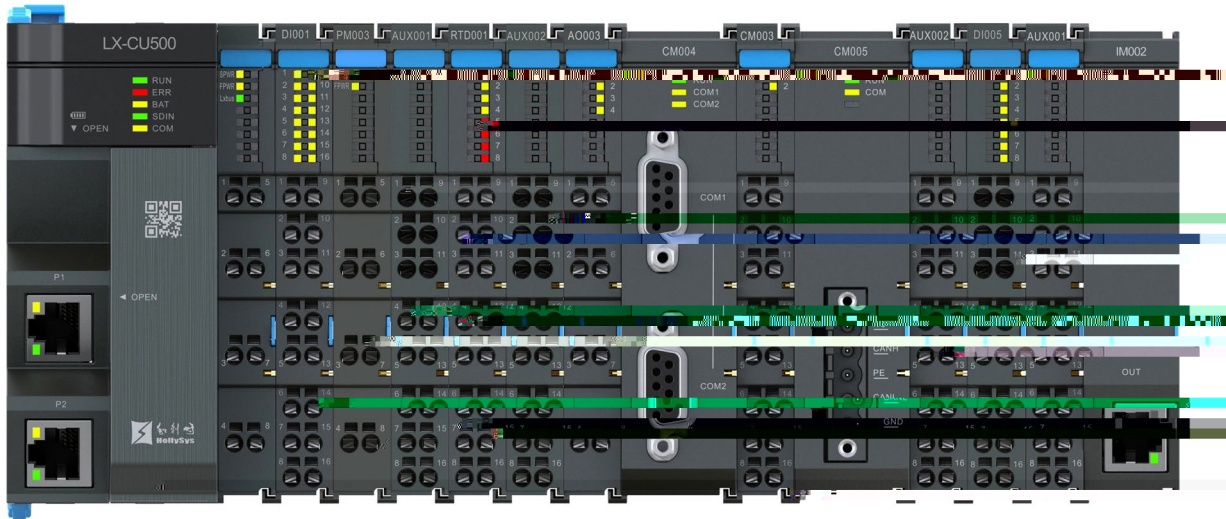

6.2 LX-PM003 Power Relay Module

6.2.1 Product Overview

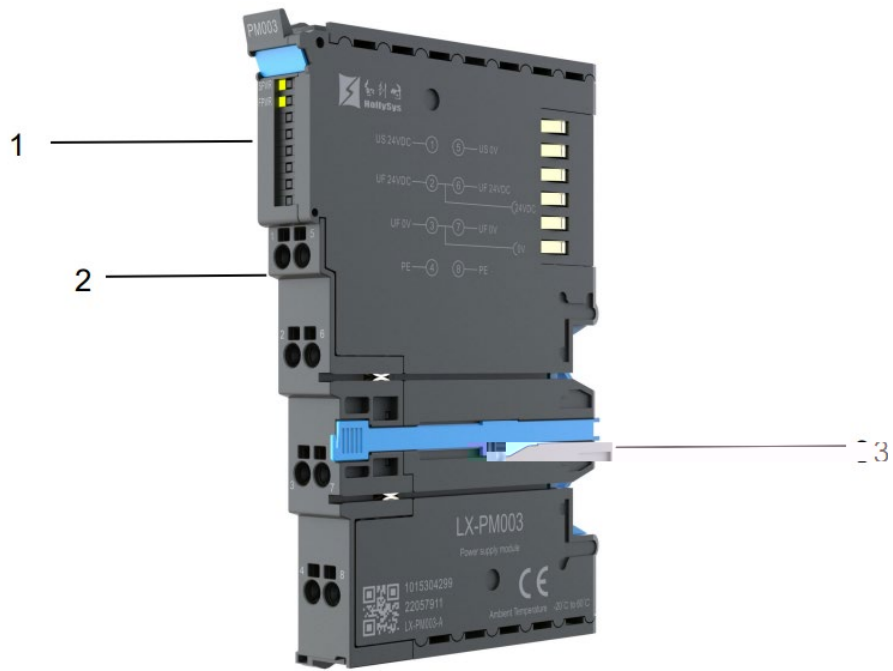

Module component schematic
Module component description table

S/N	Component Name	Instructions

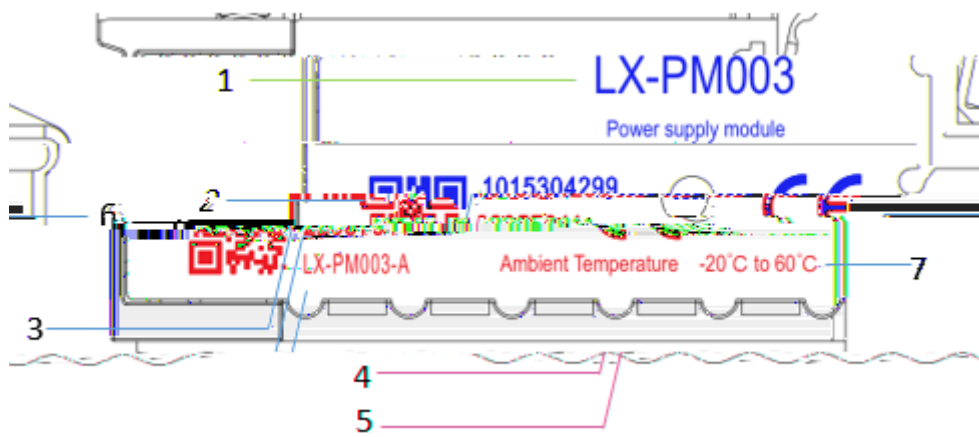

Nameplate schematic diagram

Nameplate information description table

S/N	Name	Meaning

6.2.2 Technical Indicators

Item	Specifications

Item	Specifications

6.2.3 Definition of Indicators

Name	Color	Status Description

6.2.4 Description of Terminal Components

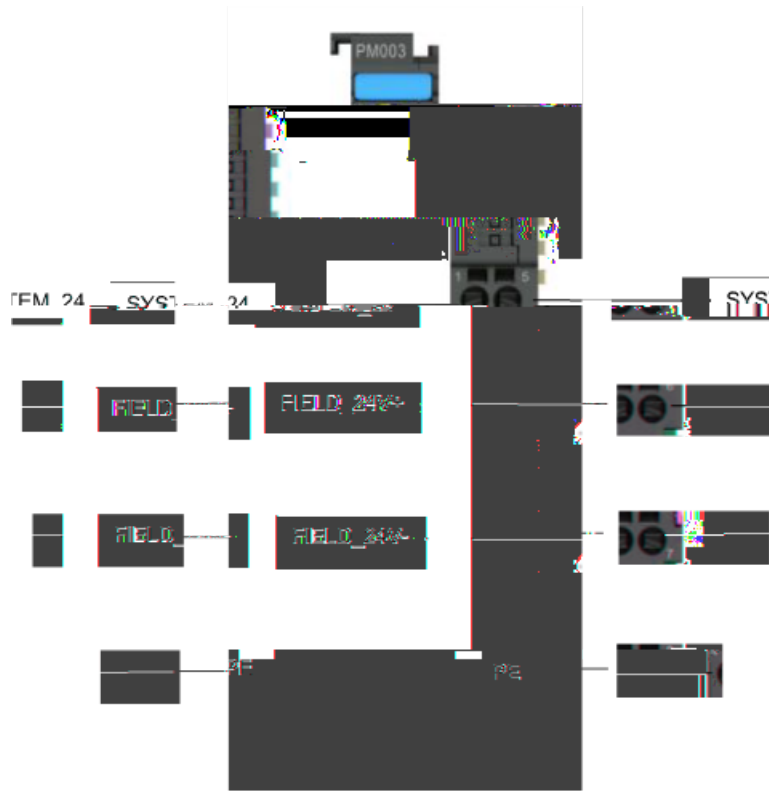

The definition of terminals

Terminal Identification	Signals	Description

-

copper wires, with an outer diameter not less than 2.5 mm² and a grounding impedance less than 4 Ω.

6.3 LX-AUX001 16-channel GND Power Potential Distribution Module

6.3.1 Product Overview

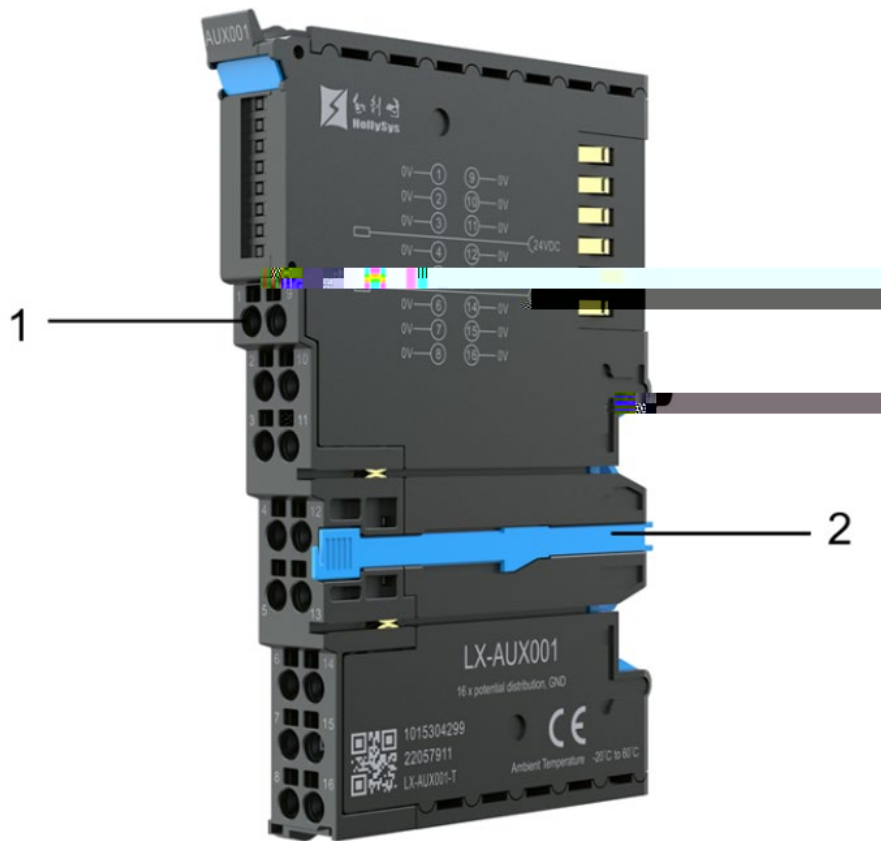

Module component schematic
Module component description table

S/N	Component Name	Instructions

--	--	--

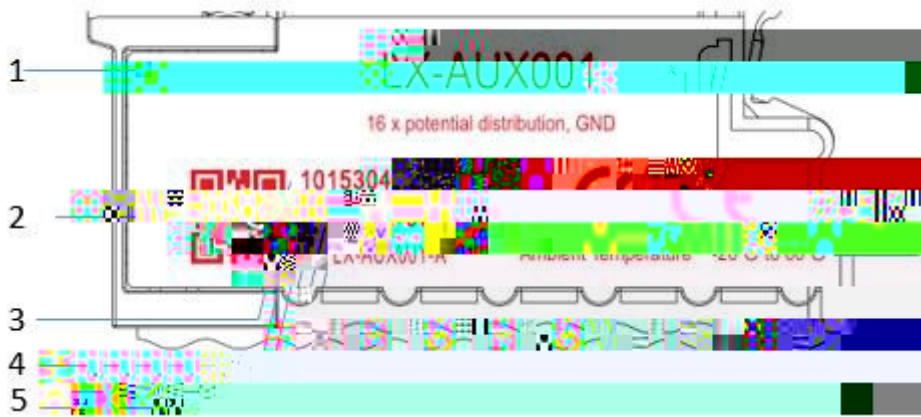

Nameplate schematic diagram
Nameplate information description table

S/N

6.3.3 Definition of Indicators

6.3.4 Description of Terminal Components

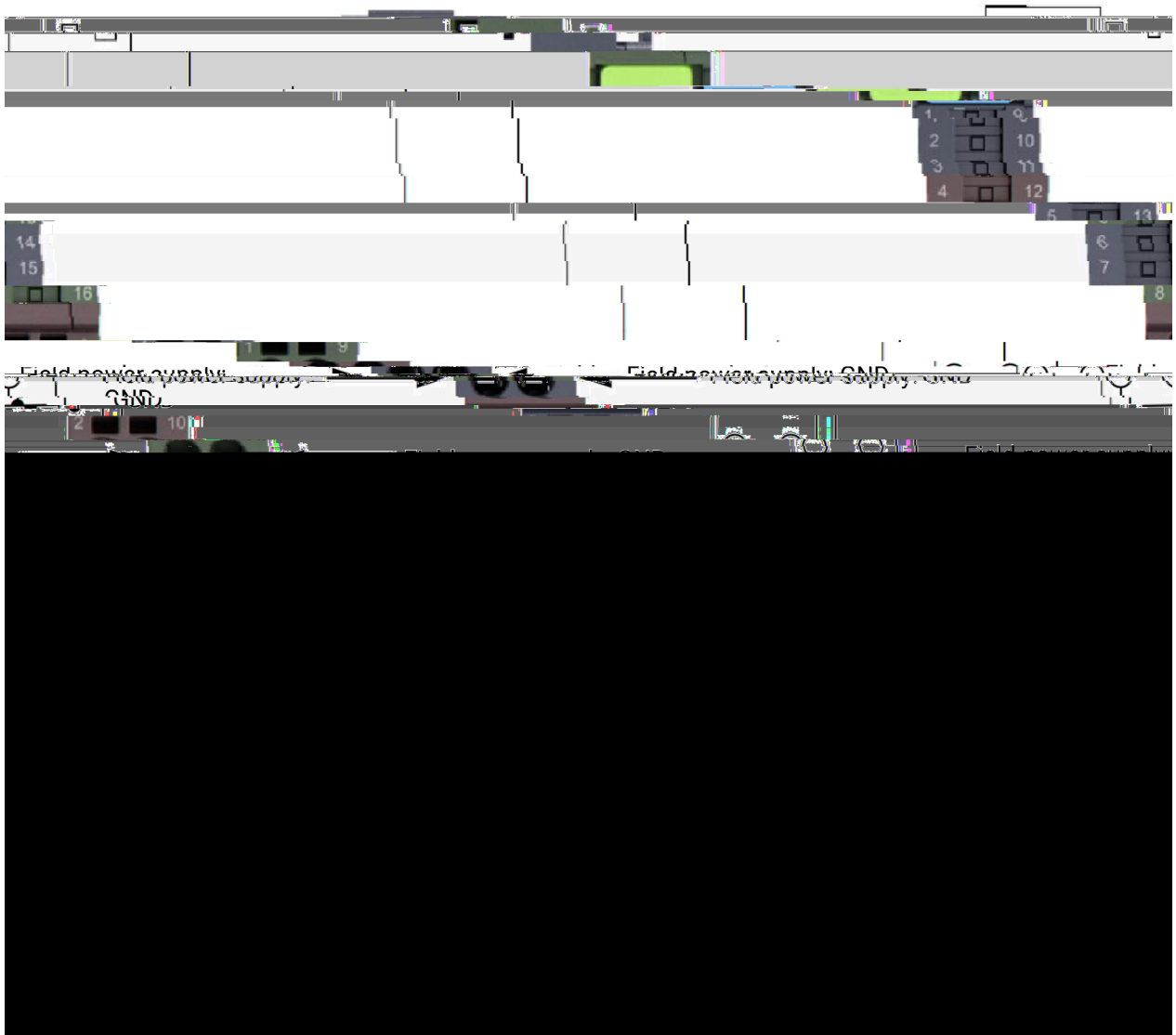

The definition of terminals

Terminal Identification	Description of Signals	Description

6.4 LX-AUX101 16-channel GND potentiometric assignment enhanced module

6.4.1 Product Overview

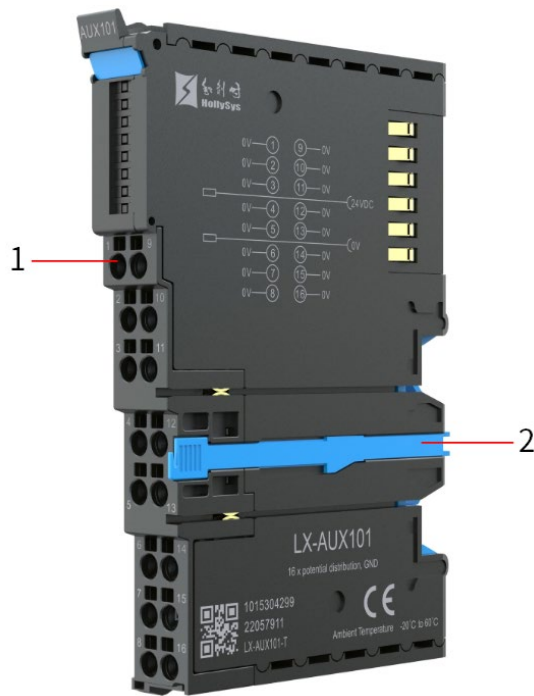

Module component schematic

Module component description table

S/N	Component Name	Instructions
-----	----------------	--------------

--	--	--

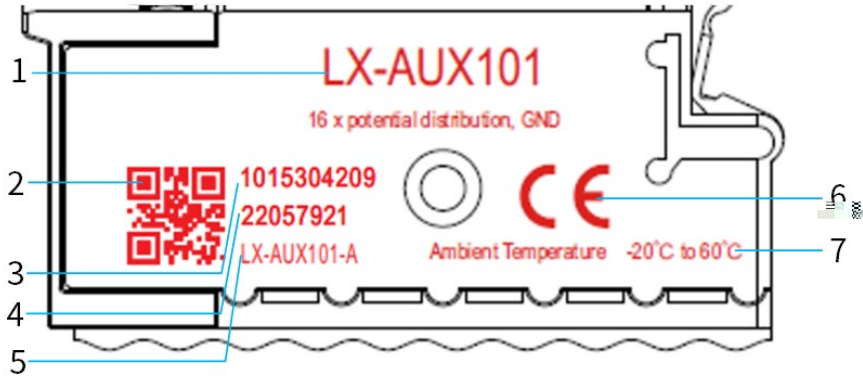

Nameplate schematic diagram

Nameplate information description table

S/N	Name	Meaning

6.4.2 Technical Indicators

Item	Specifications

Item	Specifications

6.4.3 Definition of Indicators

6.4.4 Description of Terminal Components



The definition of terminals

Terminal Identification	Description of Signals	Description

6.5 LX-AUX002 16-Channel 24 V Power Potential Distribution Module

6.5.1 Product Overview

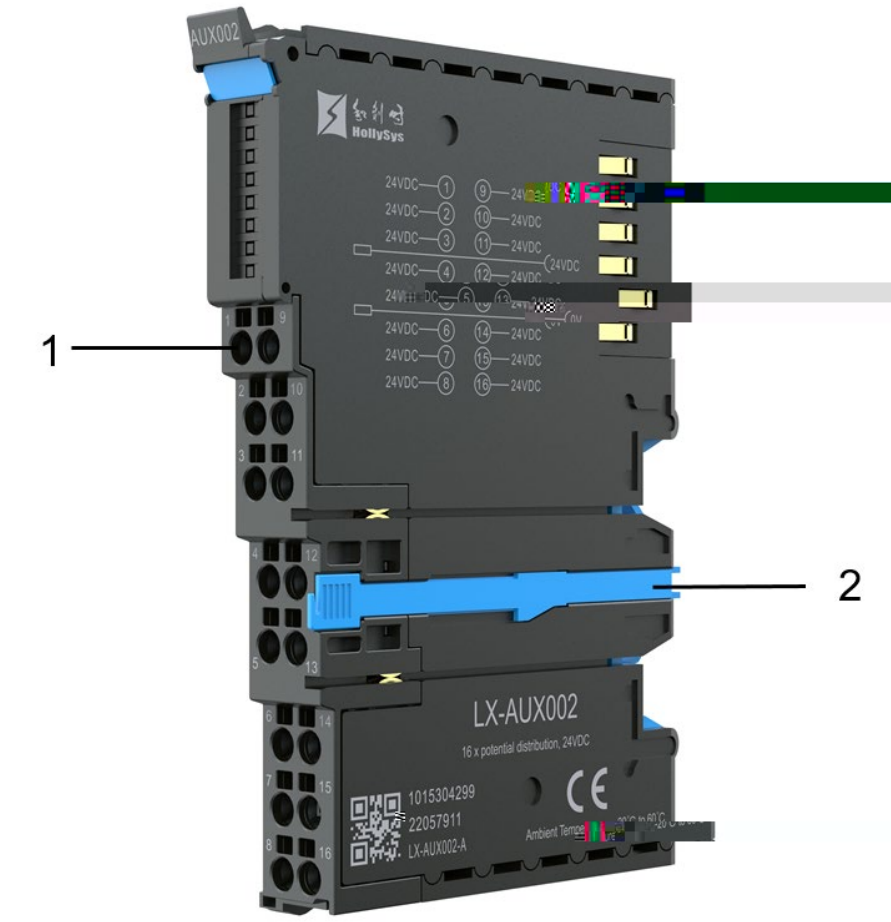

Module component schematic
Module component description table

S/N	Component Name	Instructions
-----	----------------	--------------

6.5.3 Definition of Indicators

6.5.4 Description of Terminal Components

The definition of terminals

Terminal Identification	Description of Signals	Description

6.6 LX-AUX102 16-Channel 24 V Power Potential Distribution Module

6.6.1 Product Overview

--	--	--

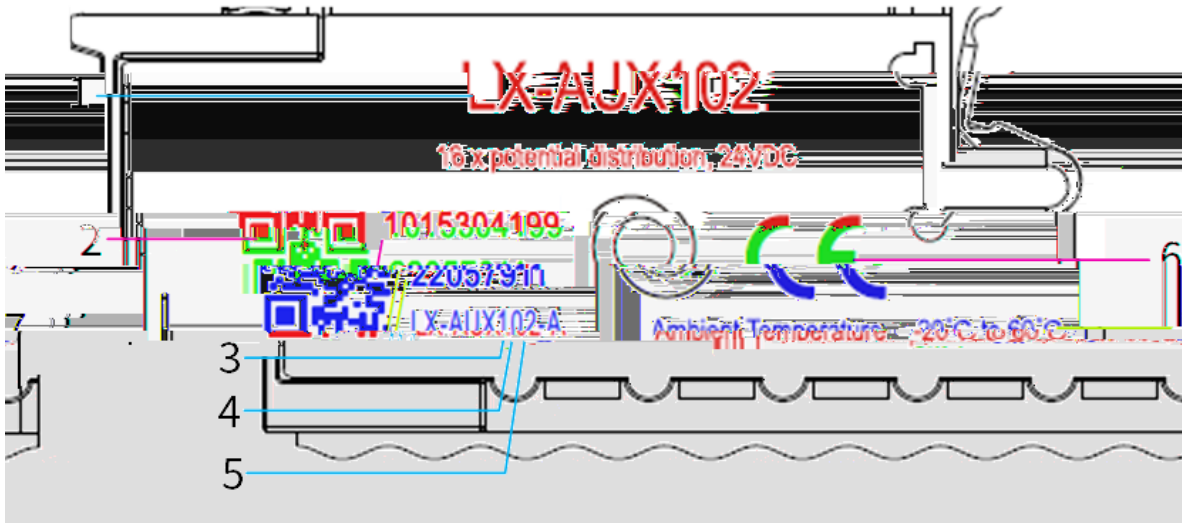

Nameplate schematic diagram

Nameplate information description table

S/N	Name	Meaning

6.6.2 Technical Indicators

Item	Specifications

Item	Specifications
------	----------------

6.6.3 Definition of Indicators

6.6.4 Description of Terminal Components

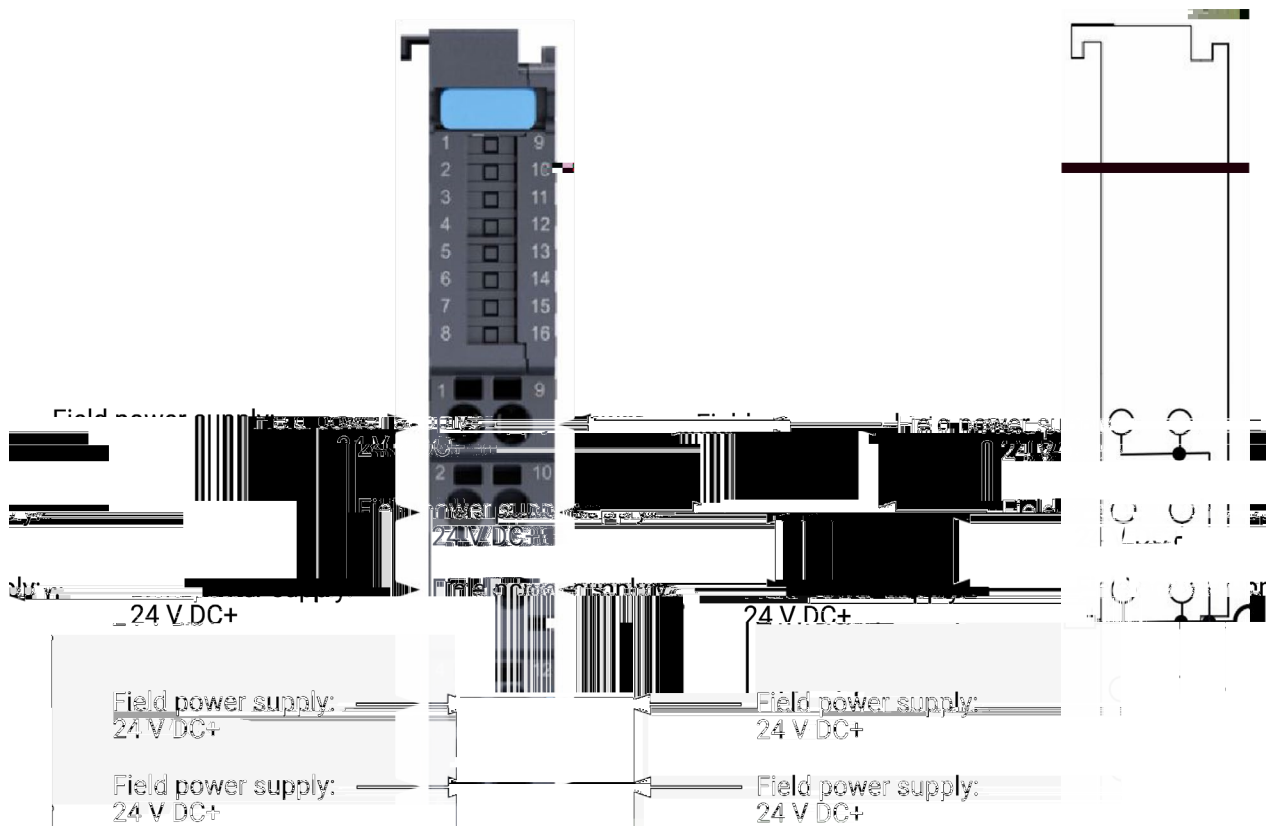

The definition of terminals

Terminal Identification	Description of Signals	Description
-------------------------	------------------------	-------------

--	--	--

Chapter 7 Interface Module

LX Series Programmable Controller Communication Manual

7.1 LX-CM001 2-Channel RS-232 Serial

Communication Terminal Interface Module

7.1.1 Product Overview

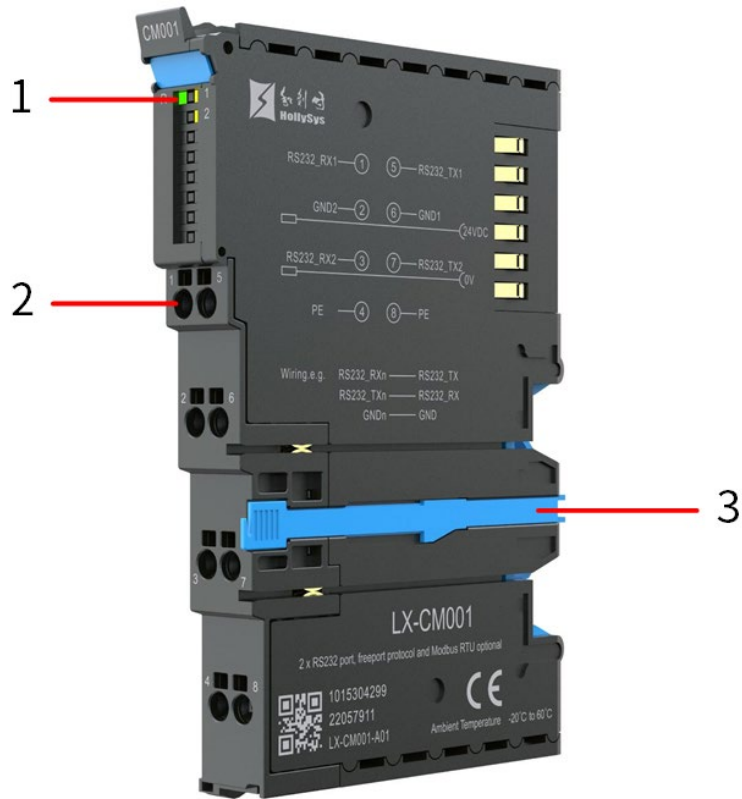

Module component schematic
Module component description table

S/N	Component Name	Instructions

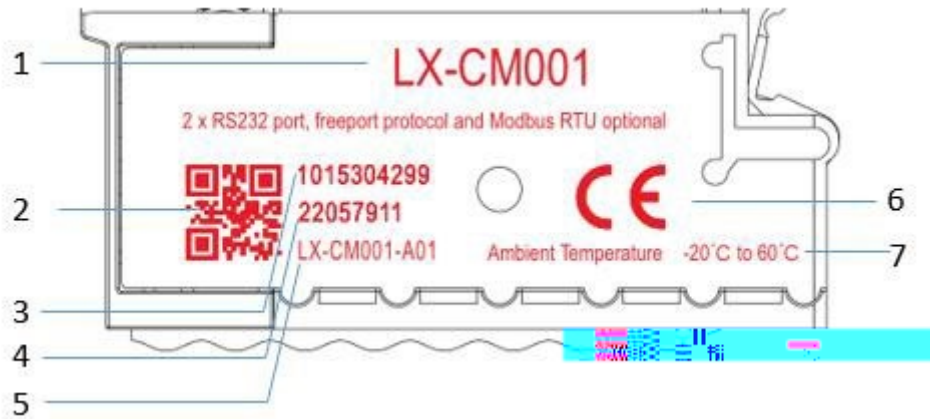

Nameplate schematic diagram

Nameplate information description table

S/N	Name	Meaning

7.1.2 Technical Indicators

Item	Specifications

Item	Specifications

Item	Specifications
LX-bus bus interface	

Communication interface	

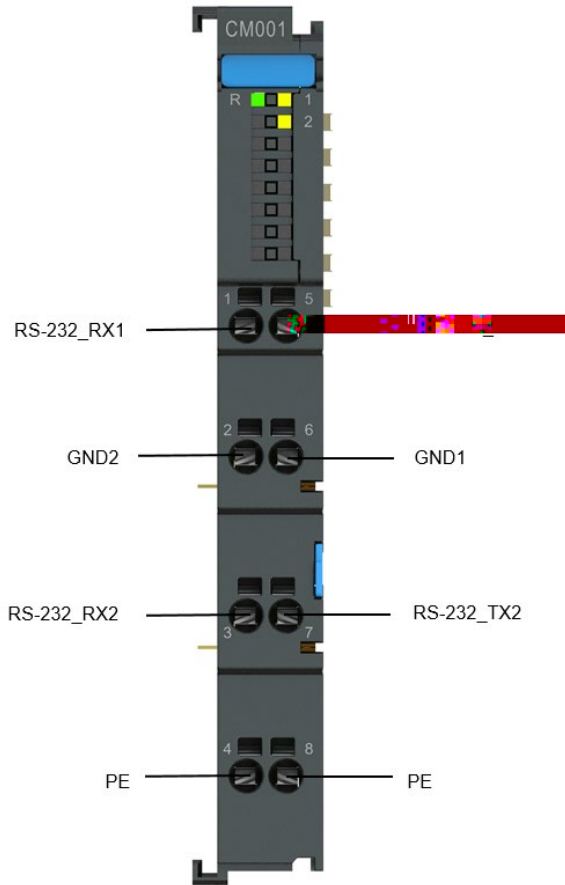

The definition of terminals

Terminal Identification	Description of Signals	Description	Terminal Identification	Description of Signals	Description

7.1.5 Parameter specification

Channel parameter information description

Configuration Parameters	Function Description	Parameter Range	Configuration Description

7.2 LX-CM002 2-channel RS-232 Serial

Communication DB9 Interface Module

7.2.1 Product Overview

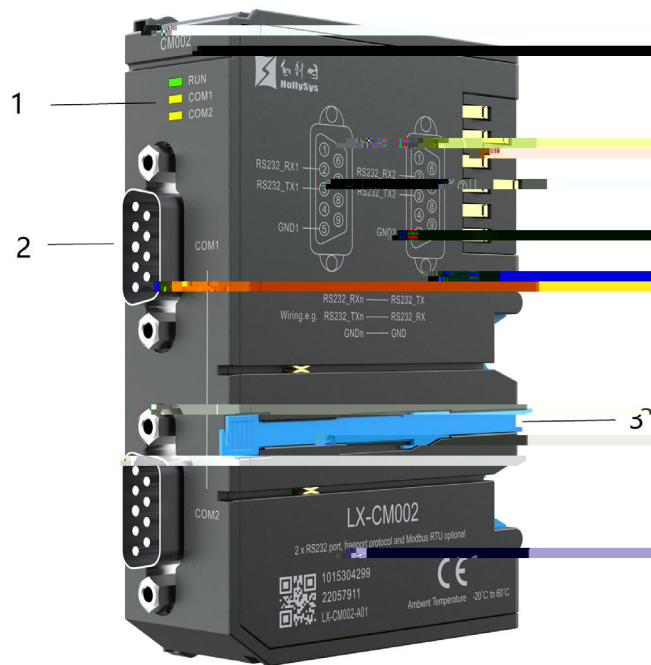

Module component schematic

Module component description table

S/N	Component Name	Instructions

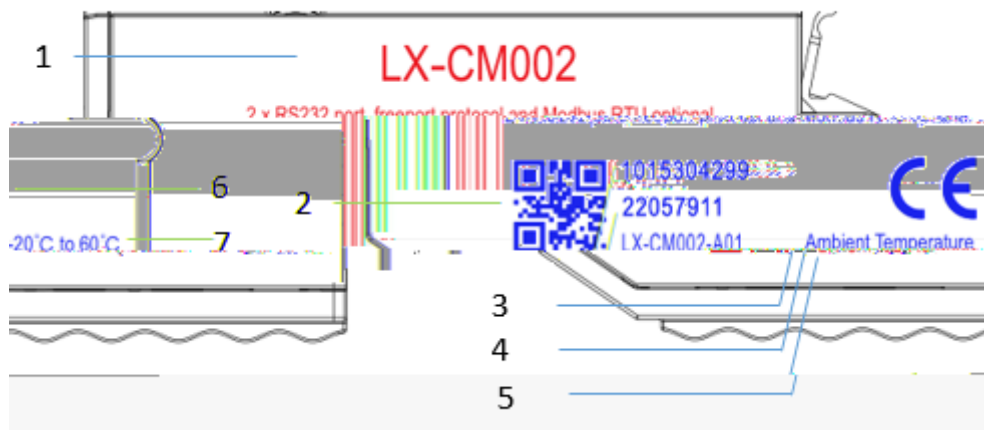

Nameplate schematic diagram

Nameplate information description table

S/N	Name	Meaning

	1000VAC@1min@5mA, channel

7.2.3 Status Indicators

Name	Color	Status Description

7.2.4 Description of Terminal Components

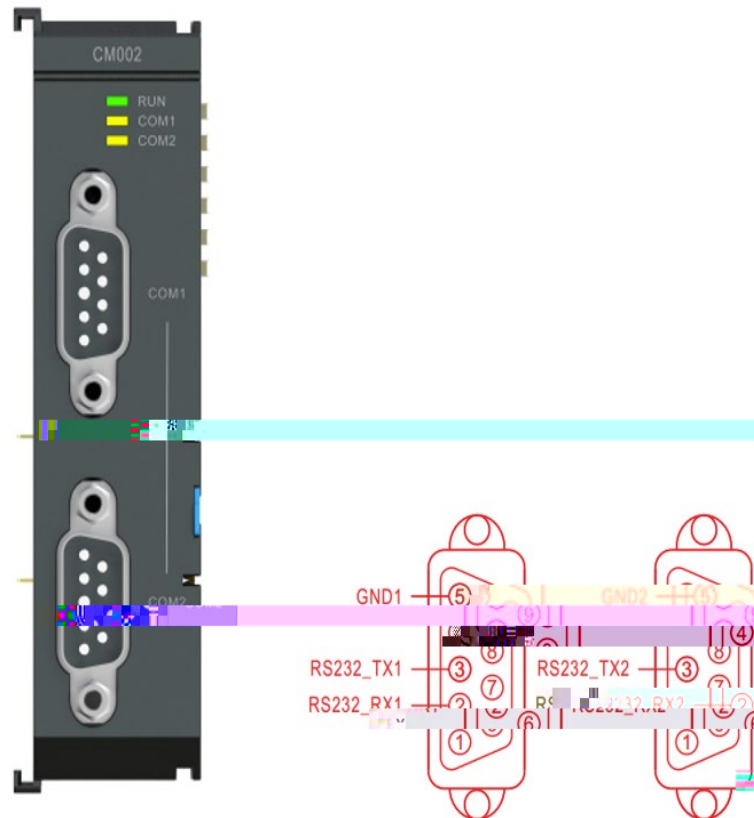

The definition of terminals

Terminal	Description of	Description	Terminal	Description of	Description
----------	----------------	-------------	----------	----------------	-------------

Identification	Signals		Identification	Signals	

7.2.5 Parameter specification

Channel parameter information description

Configuration Parameters	Function Description	Parameter Range	Configuration Description

7.3 LX-CM003 2-channel RS-485 Serial Communication Terminal Interface Module

7.3.1 Product Overview

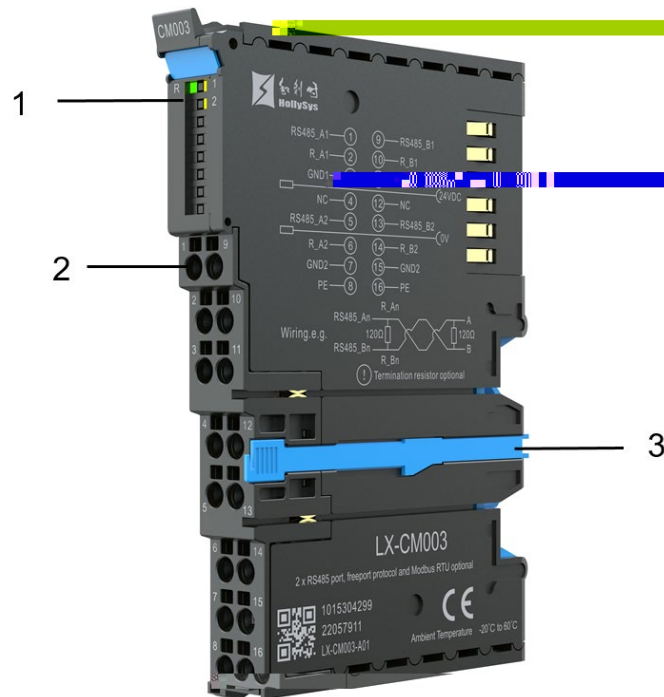

Module component schematic
Module component description table

S/N	Component Name	Instructions

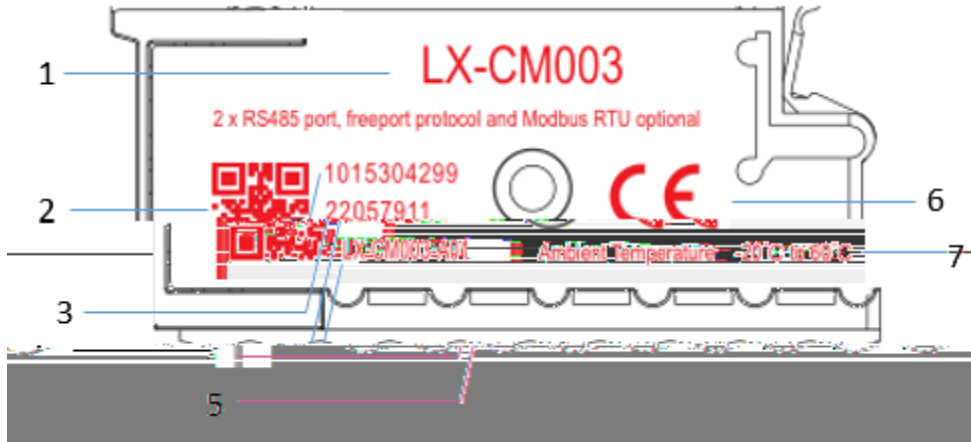

Nameplate schematic diagram

Nameplate information description table

S/N	Name	Meaning

Item	Specifications
LX-bus bus interface	
Communication interface	

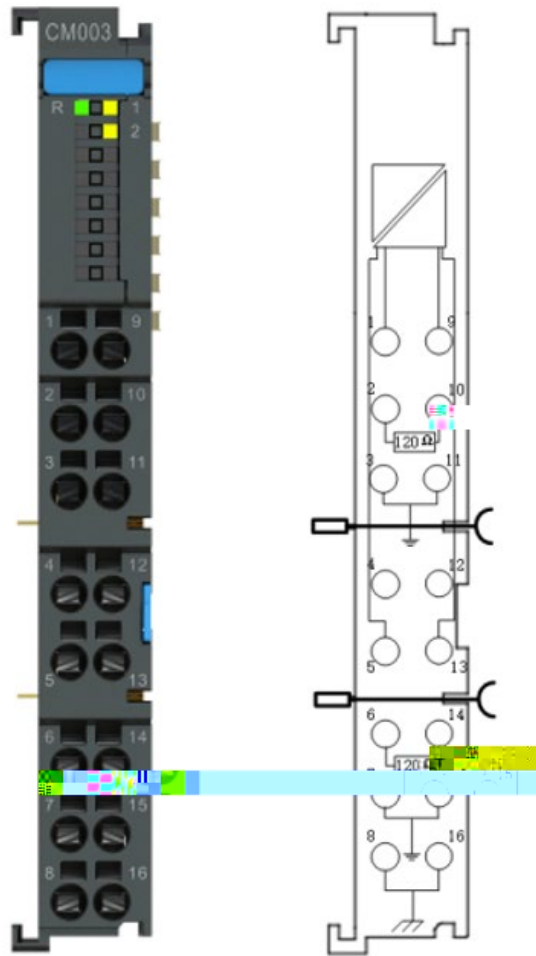

The definition of terminals

Terminal Identification	Description of Signals	Description	Terminal Identification	Description of Signals	Description

7.3.5 Parameter specification

Channel parameter information description

Configuration Parameters	Function Description	Parameter Range	Configuration Description

7.4 LX-CM004 2-Channel RS-485 Serial

Communication DB9 Interface Module

7.4.1 Product Overview

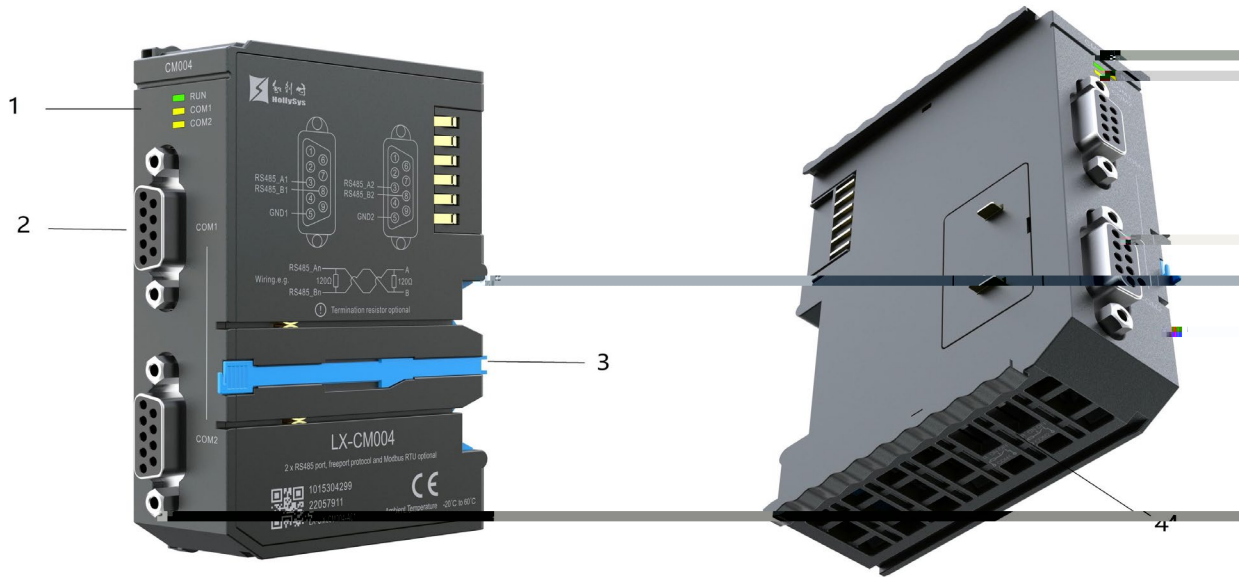

Module component schematic
Module component description table

S/N	Component Name	Instructions

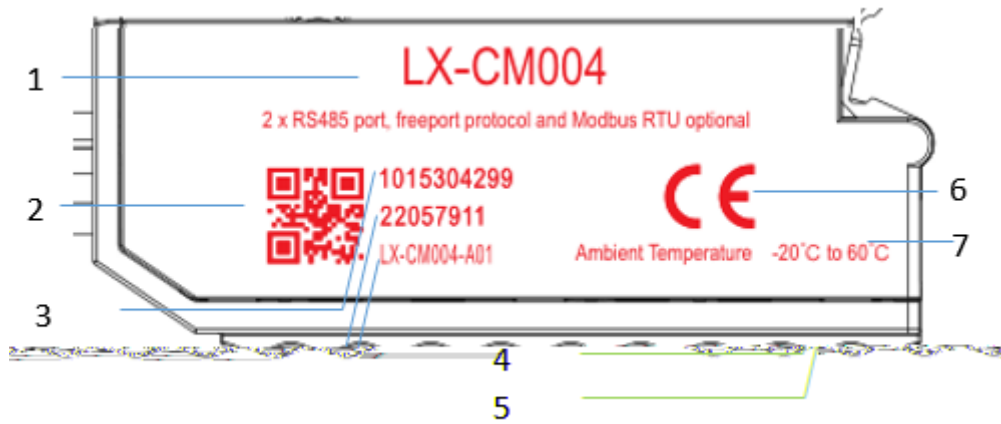

Nameplate schematic diagram

Nameplate information description table

S/N	Name	Meaning

7.4.2 Technical Indicators

Item	Specifications

Item	Specifications

Item	Specifications
LX-bus bus interface	
Communication interface	
	1000VAC@1min@5mA, channel

7.4.3 Status Indicators

Name	Color	Status Description

7.4.4 Description of Terminal Components

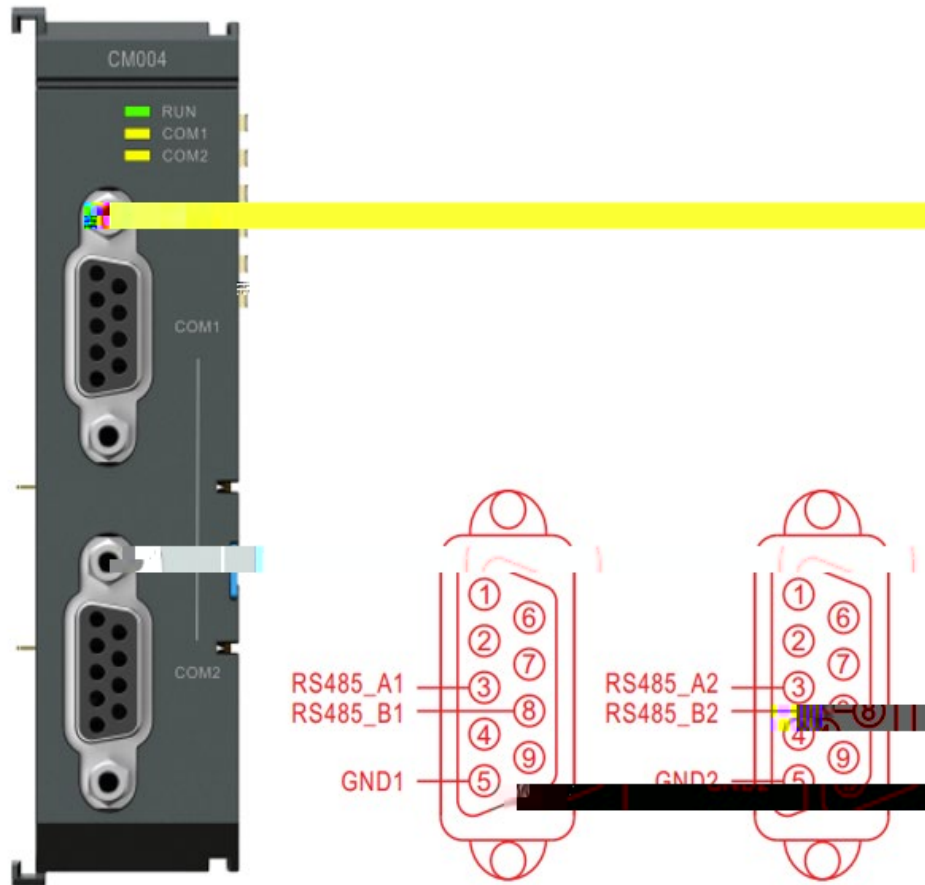

The definition of terminals

Terminal Identification	Description of Signals	Description

7.4.5 Parameter specification

Channel parameter information description

Configuration Parameters	Function Description	Parameter Range	Configuration Description

Chapter 8 Communication Module

8.1 LX-CM005 DeviceNet Slave Station Protocol Module

8.1.1 Product Overview

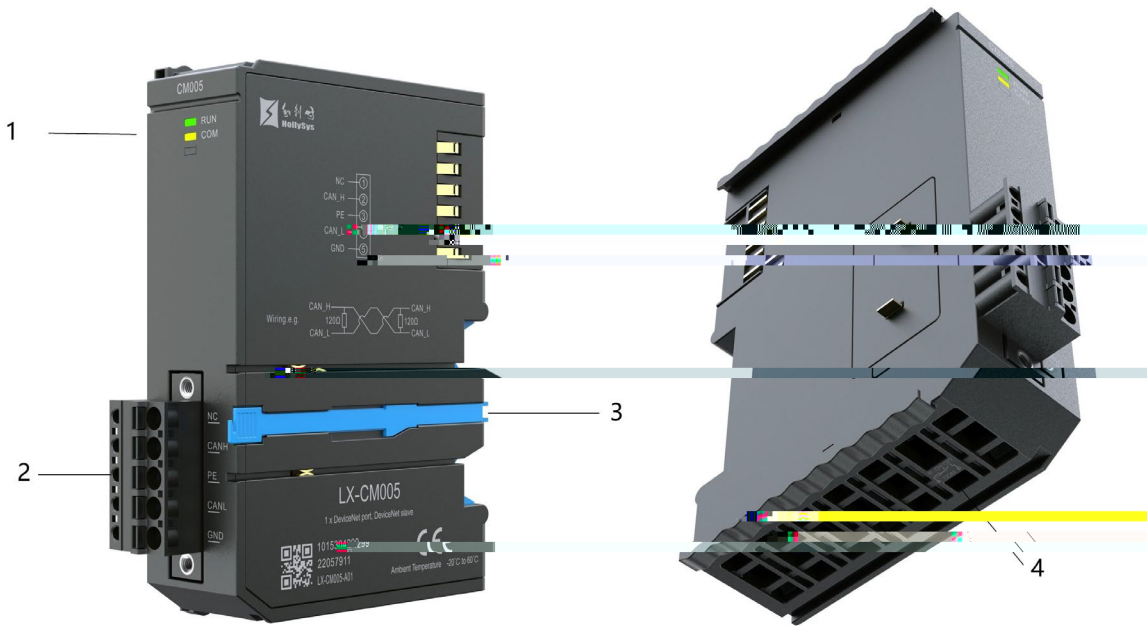

Module component schematic
Module component description table

S/N	Component Name	Instructions

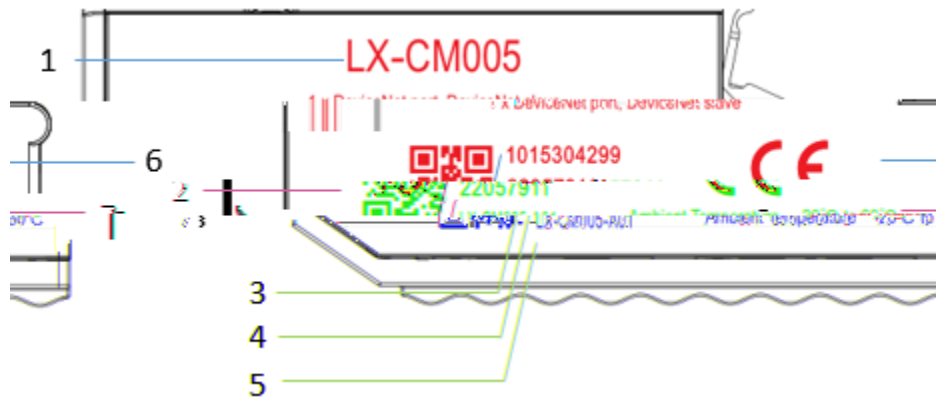

Nameplate schematic diagram

Nameplate information description table

S/N	Name	Meaning

8.1.2 Technical Indicators

Item	Specifications

Item	Specifications
System power supply mode	Power supply via LX-bus interface
Rated voltage	24 V DC
System side Power Consumption	Max 1.5W

Item	Specifications
LX-bus bus interface	
Communication interface	
	1000VAC@1min@5mA, channel

8.1.3 Status Indicators

Name	Color	Status Description

8.1.4 Description of Terminal Components

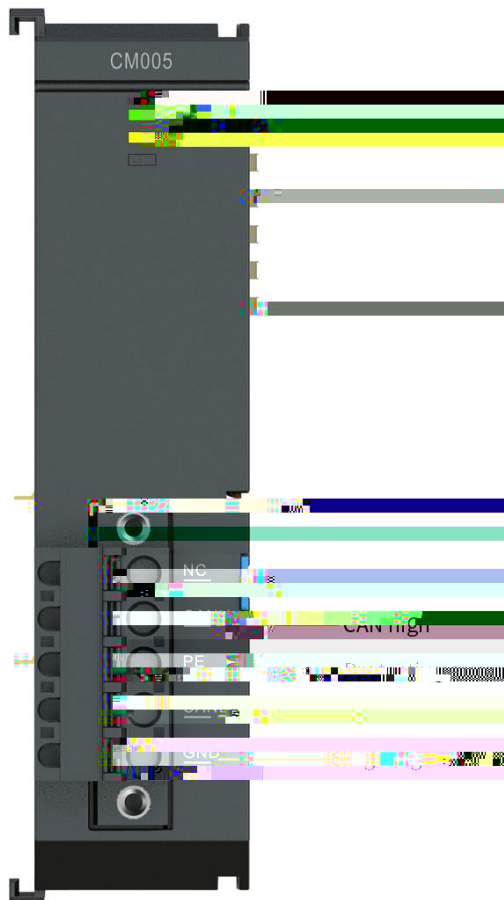

The definition of terminals

Terminal Identification	Description of Signals	Description

8.2 LX-CM006 DeviceNet Master Station Protocol Module

8.2.1 Product Overview

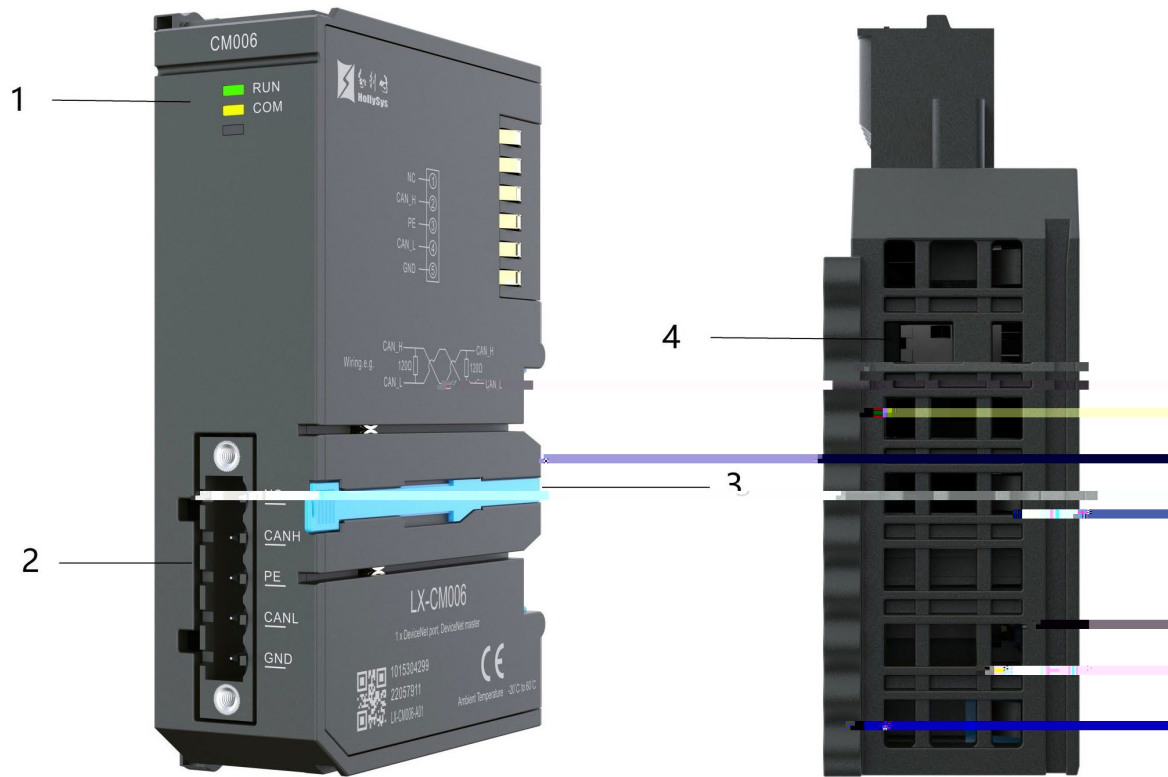

Module component schematic

Module component description table

S/N	Component Name	Instructions

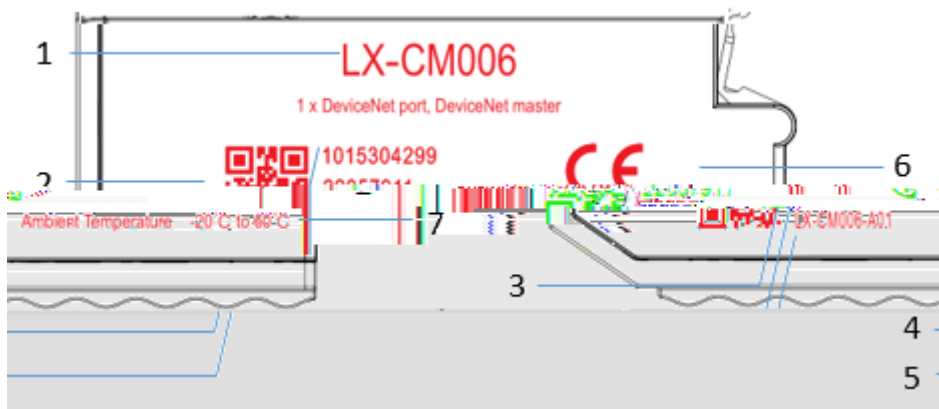

Nameplate schematic diagram

Nameplate information description table

S/N	Name	Meaning

8.2.2 Technical Indicators

Item	Specifications

Item	Specifications

Item	Specifications
LX-bus bus interface	
Communication interface	

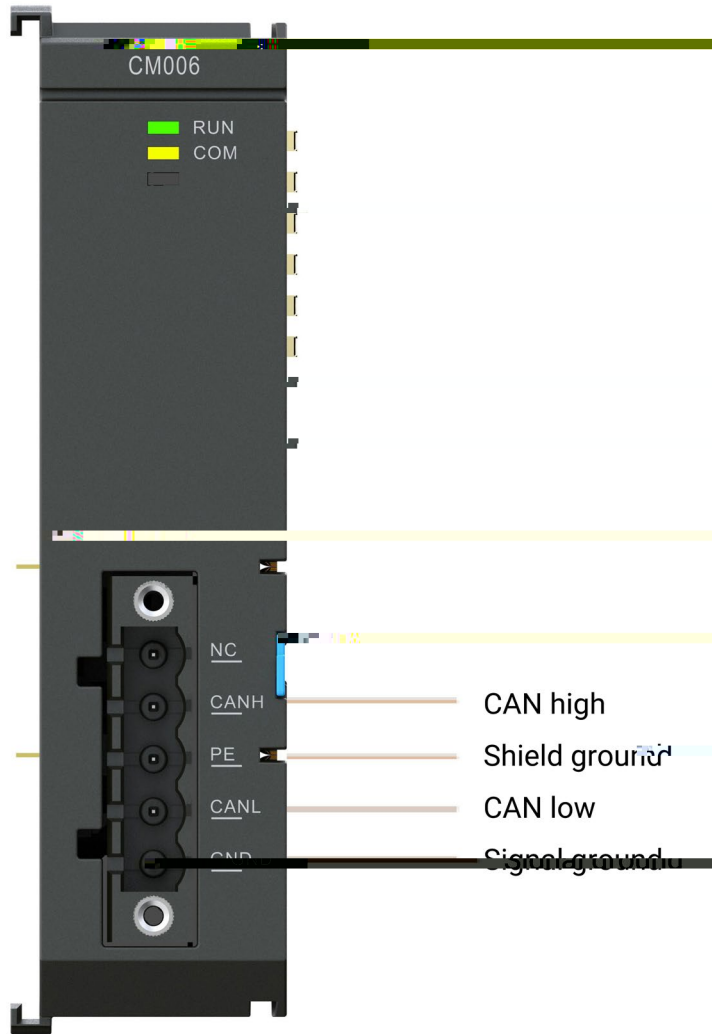

The definition of terminals

Terminal Identification	Description of Signals	Description

8.2.5 Parameter specification

Parameter description for DeviceNet slave

Configuration Parameters	Function Description	Parameter Range	Configuration Description

8.2.6 Diagnostic Alarm

Diagnostic information description

Diagnosis	Diagnostic Description	Diagnostic Value

8.3 LX-CM009 Profibus DP Master Communication Module

8.3.1 Product Overview

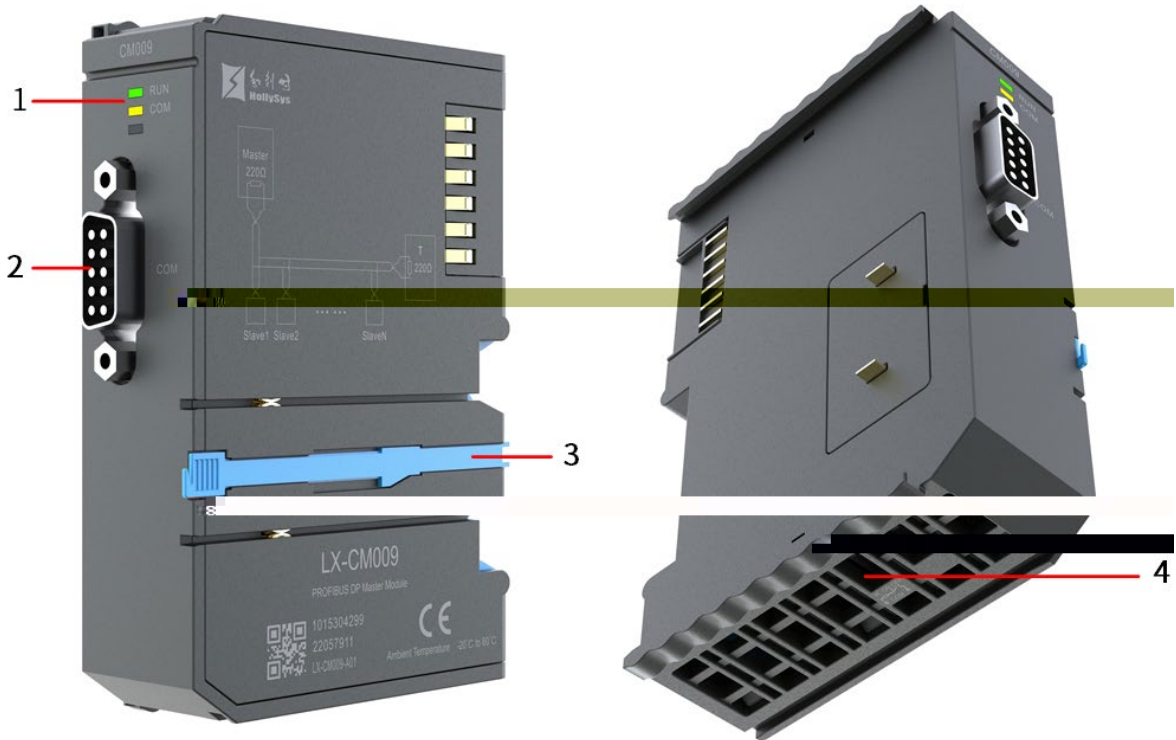

Module component schematic
Module component description table

S/N	Component Name	Instructions

8.3.2 Technical Indicators

Item	Specifications

Item	Specifications

Item	Specifications
LX-bus bus interface	
Communication interface	

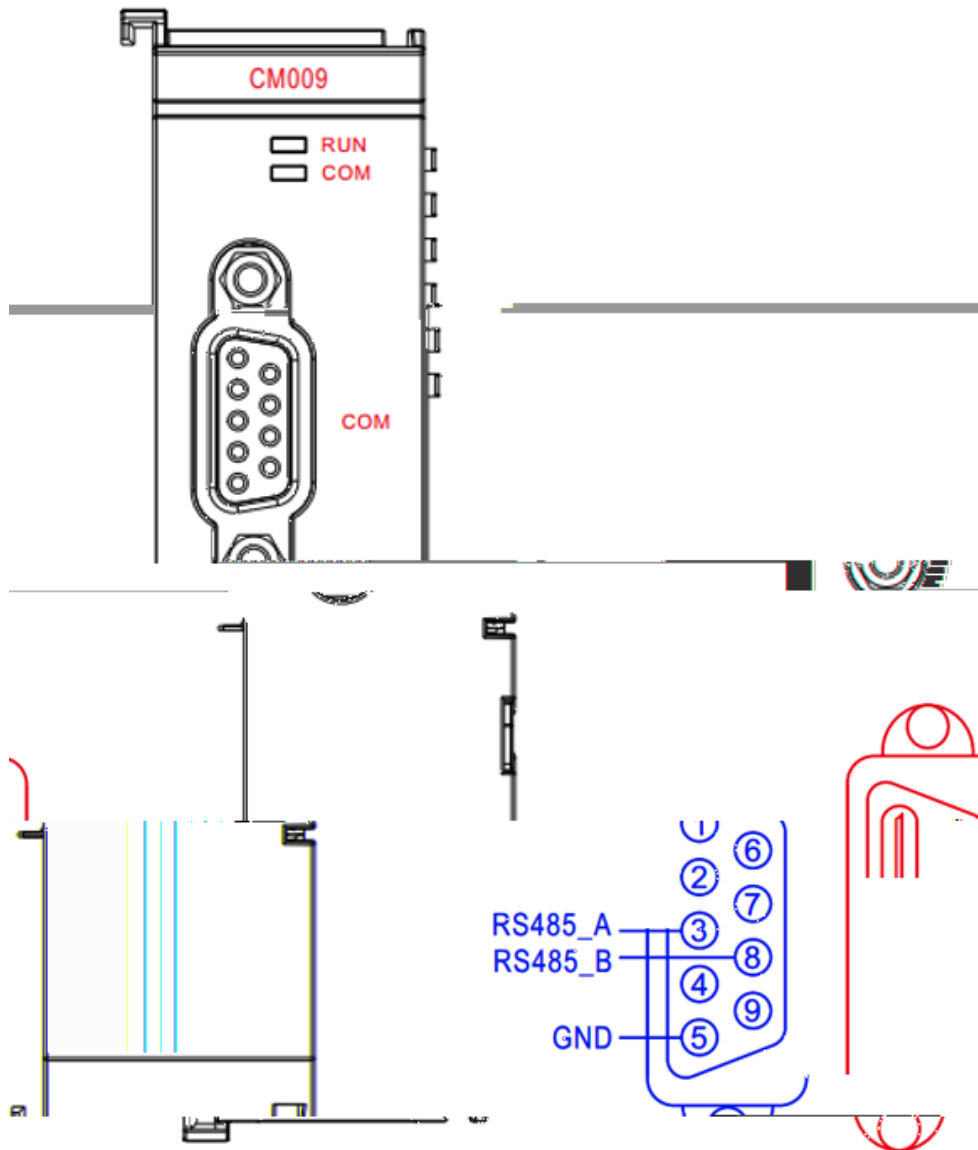

The definition of terminals

Terminal Identification	Description of Signals	Description	Terminal Identification	Description of Signals	Description

8.3.5 Parameter Configuration



Channel Description	Channel Number	Channel Name	GroupName	Channel Type	Bytes	Channel Address	
Master_Cycle_Counter	1	E6_IN_1	...	UINT	2	%W0	Me
save_Online_Status	2	E6_IN_2	...	UDINT	4	%ID4	Sl
save_Diag_Flag	3	E6_IN_3	...	UDINT	4	%ID8	Sl

**LX-CM009 EtherCAT IO Mapping
Parameter specification**

Configuration Parameters	Configuration Description
--------------------------	---------------------------

--	--



Device Configuration		Information
Project	Content	
Protocol name	DP_MASTER	
Alias	DP_MASTER	
Port	COM	
Baud rate	1500.00kBits/s	
TSL(0~65535)	400	
Min TSDR(0~65535)	11	
Max TSDR(0~65535)	150	
TQUI failure/Repeater switching time(0~255)	0	
TSET(0~255)	1	
TTR	4449	
Gap	10	
Slave interval(0~65535)	1200	
Poll timeout	1200	
Data control time	1200	
Protocol	PROFIBUS-DP	
Address range of slave station	2~125	
Position of master/slave station	Profibus-DP master station	

DP Master device configuration page



Add DP Device

MD810_gateway(2:MD810-gateway) X		
Device Configuration Channel Information		
Project	Content	
Module Type	MD810-gateway	
Alias	MD810_gateway	
Description	MD810gw.GSD HW=0000 SW=V.1.03.03	
GSD File Name	MD810gw.GSD	
Device Address	2(Double-click Configuration)	
Redundancy	NO	
Input Starting Byte Offset(%IB)	Not configured	
Output Starting Byte Offset(%OB)	Not configured	
	Device Property	Double-click Configuration
	Vendor Name	INOVANCE
	Version	1.06
	HW Version	0000
	SW Version	V.1.03.03
	Device Type	9@INOVANCE/PROFIBUS@DP

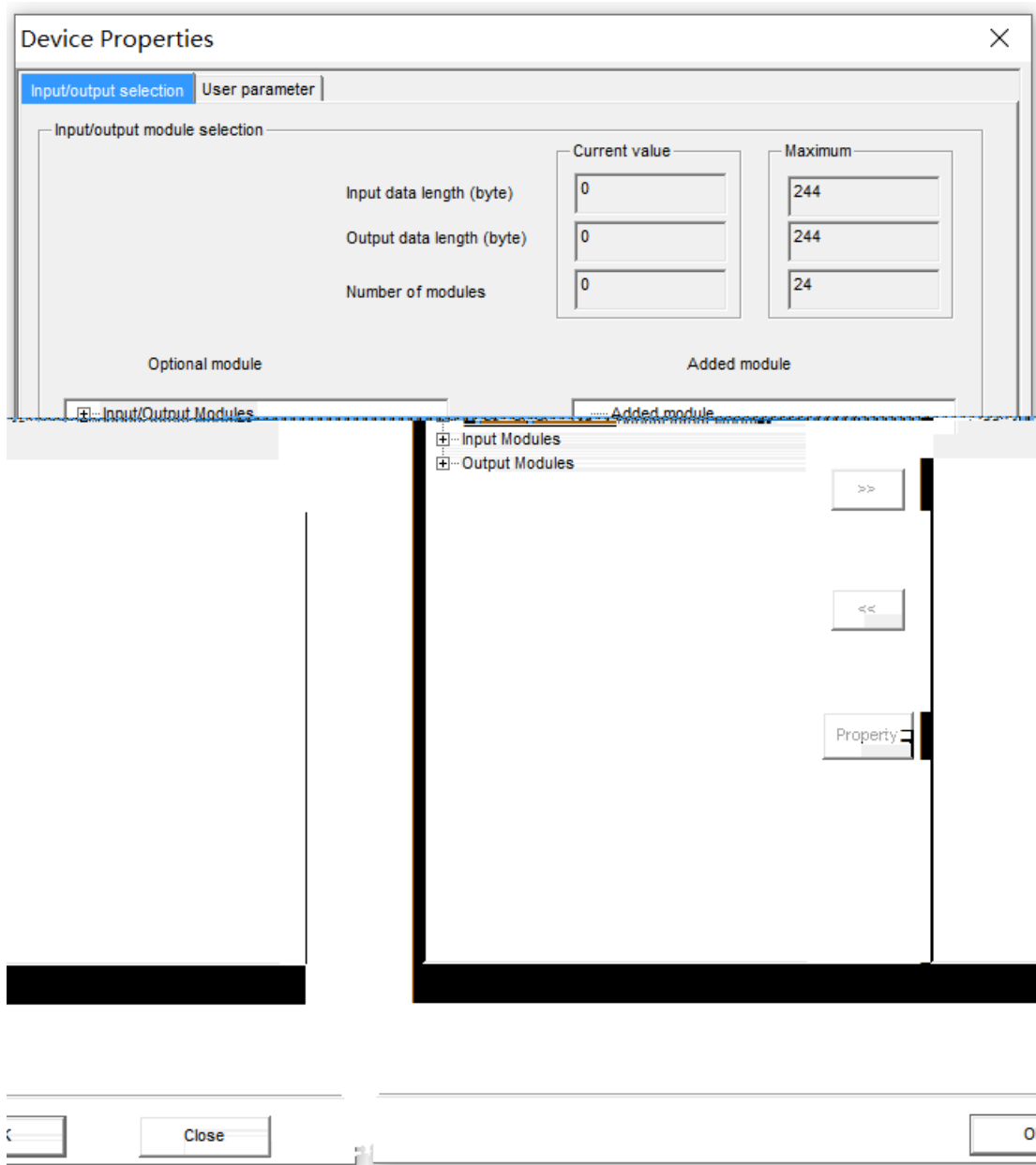

(a)

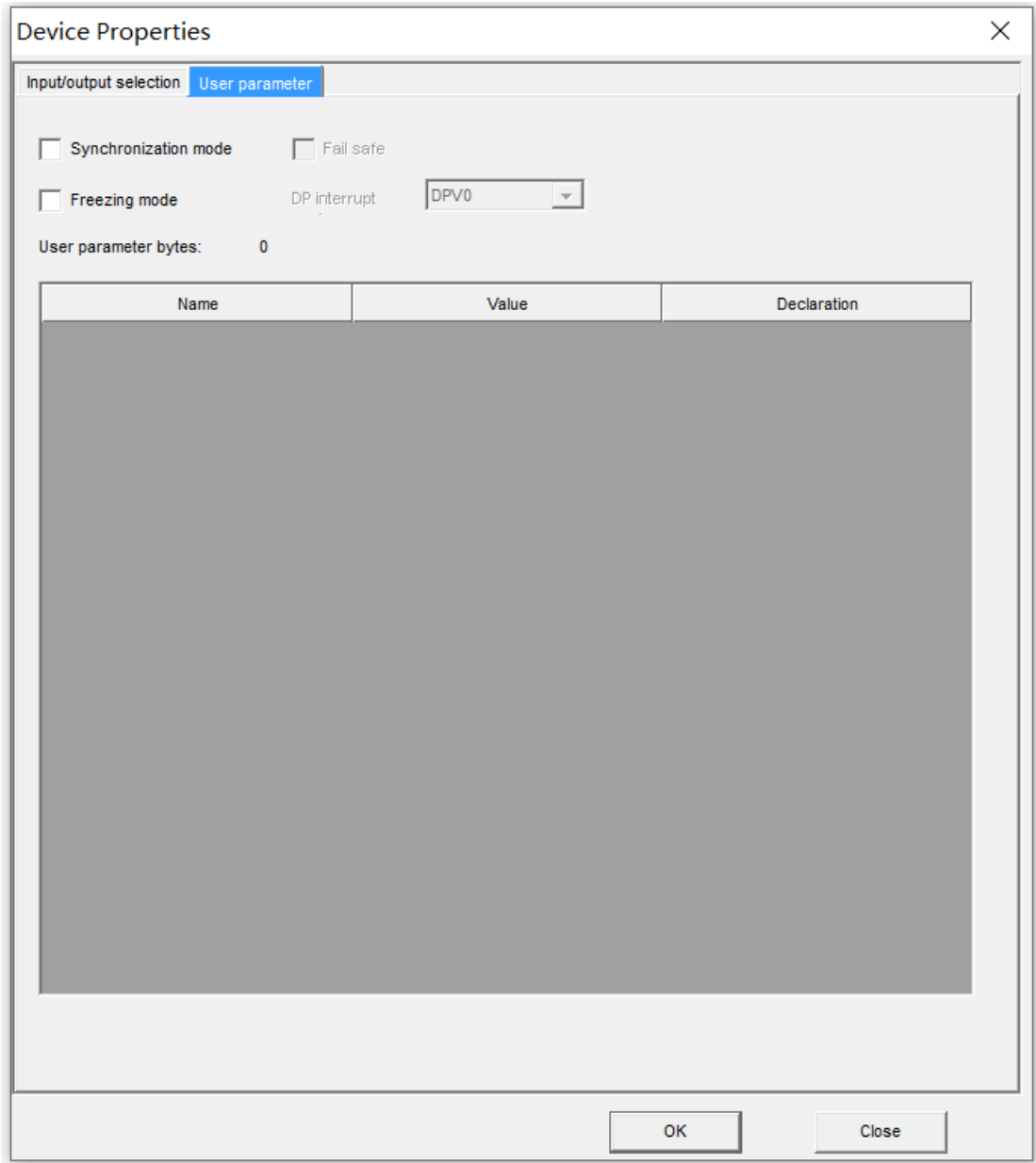

(b)

DP Slave Device Properties



8.4 LX-CM020 EtherCAT slave module

8.4.1 Product Overview

8.4.3 Status Indicators

Color	Name	Status Description

8.4.4 Description of Terminal Components

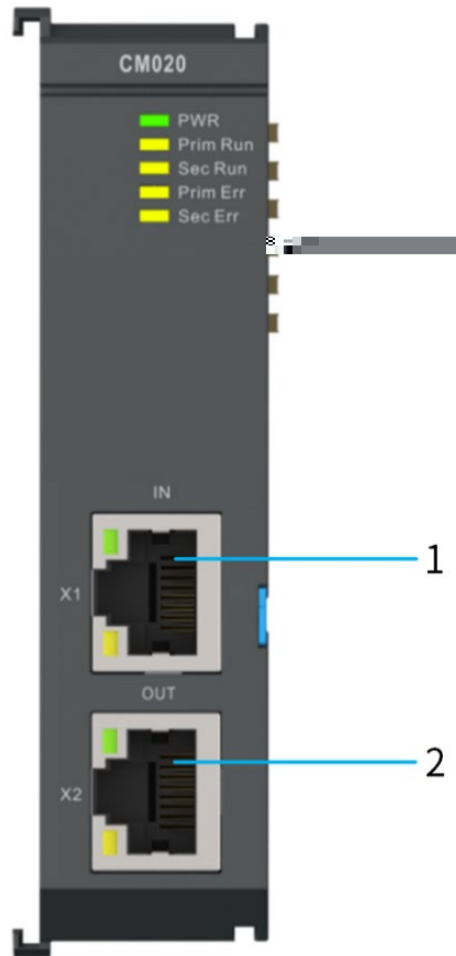

The definition of terminals

Terminal Identification	Description of Signals	Description

8.4.5 Parameter Configuration

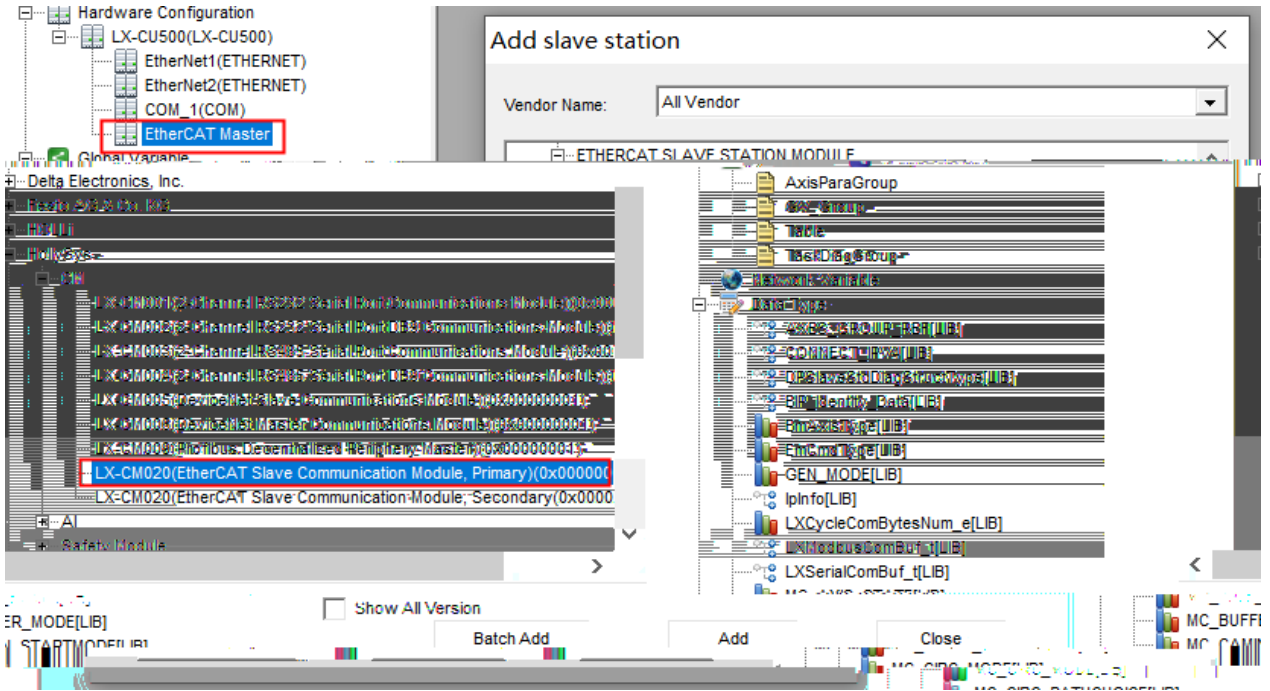

Add LX-CM020

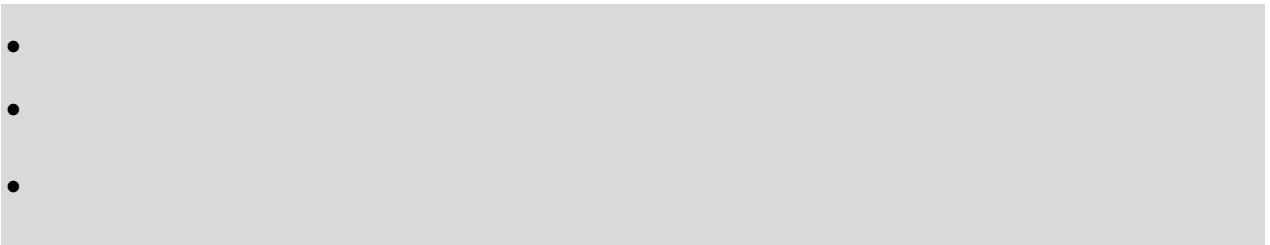

EtherCAT Slave Station Configuration | Process Parameter | Init Commands | EtherCAT IO Mapping | Information

Select input

Name	Type	Index
16#1A00 Diagnosis(Mandatory)		
<input checked="" type="checkbox"/> Not OP	BOOL	16#2000.01
<input type="checkbox"/> Other side not link	BOOL	16#2000.02
<input type="checkbox"/> Other side not OP	BOOL	16#2000.03
<input type="checkbox"/> Tx mismatch	BOOL	16#2000.04
<input type="checkbox"/> Rx mismatch	BOOL	16#2000.05
<input type="checkbox"/> Input length exceeds	BOOL	16#2000.06
<input type="checkbox"/> Output length exceeds	BOOL	16#2000.07
<input type="checkbox"/>

Select output

Name	Type	Index
16#1600 Control(Mandatory)		
<input checked="" type="checkbox"/> Control	USINT	16#2100.01
<input checked="" type="checkbox"/> 16#1601 Outputs		
<input checked="" type="checkbox"/> 16#1602 Outputs		
<input checked="" type="checkbox"/> 16#1603 Outputs		
<input checked="" type="checkbox"/> 16#1604 Outputs		
<input checked="" type="checkbox"/> 16#1605 Outputs		

New value refresh

- 16#1A01 Inputs
- 16#1A02 Inputs
- 16#1A03 Inputs
- 16#1A04 Inputs
- 16#1A05 Inputs

Process parameter setting

X

Pdo Entry

Name:

Index: Sub Index:

Data Type: Bit Length:

Count:

Add the Pdo parameter

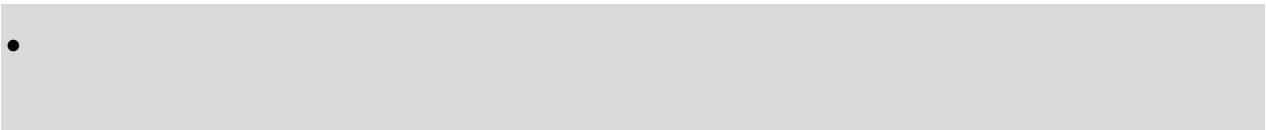

EtherCAT Slave Station Configuration | Process Parameter | Init Commands | EtherCAT IO Mapping | Information |

Select input

Name	Type	Index
<input checked="" type="checkbox"/> 16#1A00 Diagnosis(Mandatory)		
Not OP	BOOL	16#2000.01
Other side not link	BOOL	16#2000.02
Other side not OP	BOOL	16#2000.03
Tx mismatch	BOOL	16#2000.04
Rx mismatch	BOOL	16#2000.05
Input length exceeds	BOOL	16#2000.06
Output length exceeds	BOOL	16#2000.07
New value refresh	BOOL	16#2000.08
<input checked="" type="checkbox"/> 16#1A01 Inputs		
Input	WORD	16#0001.02
<input checked="" type="checkbox"/> 16#1A02 Inputs		
<input checked="" type="checkbox"/> 16#1A03 Inputs		
<input checked="" type="checkbox"/> 16#1A04 Inputs		
<input checked="" type="checkbox"/> 16#1A05 Inputs		

Select output

Name	Type	Index
<input checked="" type="checkbox"/> 16#1600 Control(Mandatory)		
Control	USINT	16#2100.01
<input checked="" type="checkbox"/> 16#1601 Outputs		
Output	WORD	16#0001.02
<input checked="" type="checkbox"/> 16#1602 Outputs		
<input checked="" type="checkbox"/> 16#1603 Outputs		
<input checked="" type="checkbox"/> 16#1604 Outputs		
<input checked="" type="checkbox"/> 16#1605 Outputs		

EtherCAT Slave Station Configuration | Process Parameter | Init Commands | EtherCAT IO Mapping | Information |

Channel Number	Channel Name	GroupName	Channel Type	Bytes	Channel Address	Channel Description
1	E6_IN_1	...	BOOL	0.1	%IX0.0	Not OP
2	E6_IN_2	...	BOOL	0.1	%IX0.1	Other side not link
3	E6_IN_3	...	BOOL	0.1	%IX0.2	Other side not OP
4	E6_IN_4	...	BOOL	0.1	%IX0.3	Tx mismatch
5	E6_IN_5	...	BOOL	0.1	%IX0.4	Rx mismatch
6	E6_IN_6	...	BOOL	0.1	%IX0.5	Input length exceeds
7	E6_IN_7	...	BOOL	0.1	%IX0.6	Output length exceeds
8	E6_IN_8	...	BOOL	0.1	%IX0.7	New value refresh
9	E6_IN_9	...	WORD	2	%IW2	Input
10	E6_OUT_9	...	USINT	1	%QB0	Control
11	E6_OUT_11	...	WORD	2	%QW2	output



LX_CM020(1001:LX-CM020)

EtherCAT Slave Station Configuration | Process Parameter | Init Commands | EtherCAT IO Mapping | Information

Channel Number	Channel Name	GroupName	Channel Type	Bytes	Channel Address	Online Value	Channel Description
1	E6_IN_1		BOOL	0.1	%DX0.0	FALSE	Not OP
2	E6_IN_2		BOOL	0.1	%DX0.1	FALSE	Other side not link
3	E6_IN_3		BOOL	0.1	%DX0.2	FALSE	Other side not OP
4	E6_IN_4		BOOL	0.1	%DX0.3	FALSE	Tx mismatch
5	E6_IN_5		BOOL	0.1	%DX0.4	FALSE	Rx mismatch
6	E6_IN_6		BOOL	0.1	%DX0.5	FALSE	Input length exceeds
7	E6_IN_7		BOOL	0.1	%DX0.6	FALSE	Output length exceeds
8	E6_IN_8		BOOL	0.1	%DX0.7	FALSE	New value refresh
9	E6_IN_9		WORD	2	%W2	0	Input
10	E6_OUT_9		USINT	1	%QB0	0	Control
11	E6_OUT_11		WORD	2	%QW2	1234	output

Debug Variables

Current Variable: E6_OUT_11

Current Value: 0

Input Value: 1234

Readback

LX_CM020(1001:LX-CM020)

EtherCAT Slave Station Configuration | Process Parameter | Init Commands | EtherCAT IO Mapping | Information

Channel Number	Channel Name	GroupName	Channel Type	Bytes	Channel Address	Online Value	Channel Description
1	E6_IN_1		BOOL	0.1	%DX0.0	FALSE	Not OP
2	E6_IN_2		BOOL	0.1	%DX0.1	FALSE	Other side not link
3	E6_IN_3		BOOL	0.1	%DX0.2	FALSE	Other side not OP
4	E6_IN_4		BOOL	0.1	%DX0.3	FALSE	Tx mismatch
5	E6_IN_5		BOOL	0.1	%DX0.4	FALSE	Rx mismatch
6	E6_IN_6		BOOL	0.1	%DX0.5	FALSE	Input length exceeds
7	E6_IN_7		BOOL	0.1	%DX0.6	FALSE	Output length exceeds
8	E6_IN_8		BOOL	0.1	%DX0.7	FALSE	New value refresh
9	E6_IN_9		WORD	2	%W2	0	Input
10	E6_OUT_9		USINT	1	%QB0	0	Control
11	E6_OUT_11		WORD	2	%QW2	1234	output

LX_CM020(1001:LX-CM020)							
EtherCAT Slave Station Configuration Process Parameter Init Commands EtherCAT IO Mapping Information							
Channel Number	Channel Name	GroupName	Channel Type	Bytes	Channel Address	Online Value	Channel Description
1	E6_IN_1		BOOL	0.1	%IX0.0	FALSE	Not OP
2	E6_IN_2		BOOL	0.1	%IX0.1	FALSE	Other side not link
3	E6_IN_3		BOOL	0.1	%IX0.2	FALSE	Other side not OP
4	E6_IN_4		BOOL	0.1	%IX0.3	FALSE	Tx mismatch
5	E6_IN_5		BOOL	0.1	%IX0.4	FALSE	Rx mismatch
6	E6_IN_6		BOOL	0.1	%IX0.5	FALSE	Input length exceeds
7	E6_IN_7		BOOL	0.1	%IX0.6	FALSE	Output length exceeds
8	E6_IN_8		BOOL	0.1	%IX0.7	FALSE	New value refresh
9	E6_IN_9		WORD	2	%IW2	1234	Input
10	E6_OUT_9		USINT	1	%QB0	0	Control
11	E6_OUT_11		WORD	2	%QW2	0	output

EtherCAT IO mapping channel system parameters description

Channel parameters	Description

Chapter 9 HUB Module

LX Series Programmable Controller Communication Manual

9.1 Notes for Use

9.2 LX-HUB106 6-channel EtherCAT HUB module

9.2.1 Product Overview

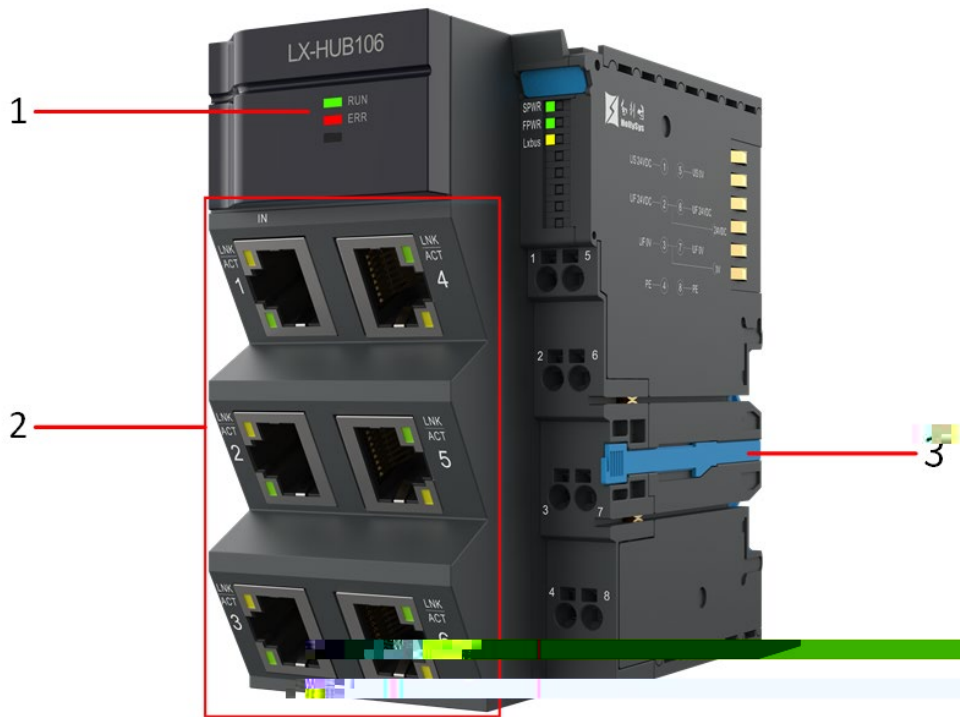

Schematic diagram of the LX-HUB106 module
Module component description table

S/N	Component Name	Instructions

-
-
-

9.2.2 Technical Indicators

Item	Specifications

Item	Specifications
LX-bus bus interface	
EtherCAT network port	
	1000VAC@1min@5mA, channel

9.2.3 Status Indicators

Definition of indicator lights

Color	Name	Status Description

9.3 LX-HUB107 6-channel EtherCAT HUB module

9.3.1 Product Overview

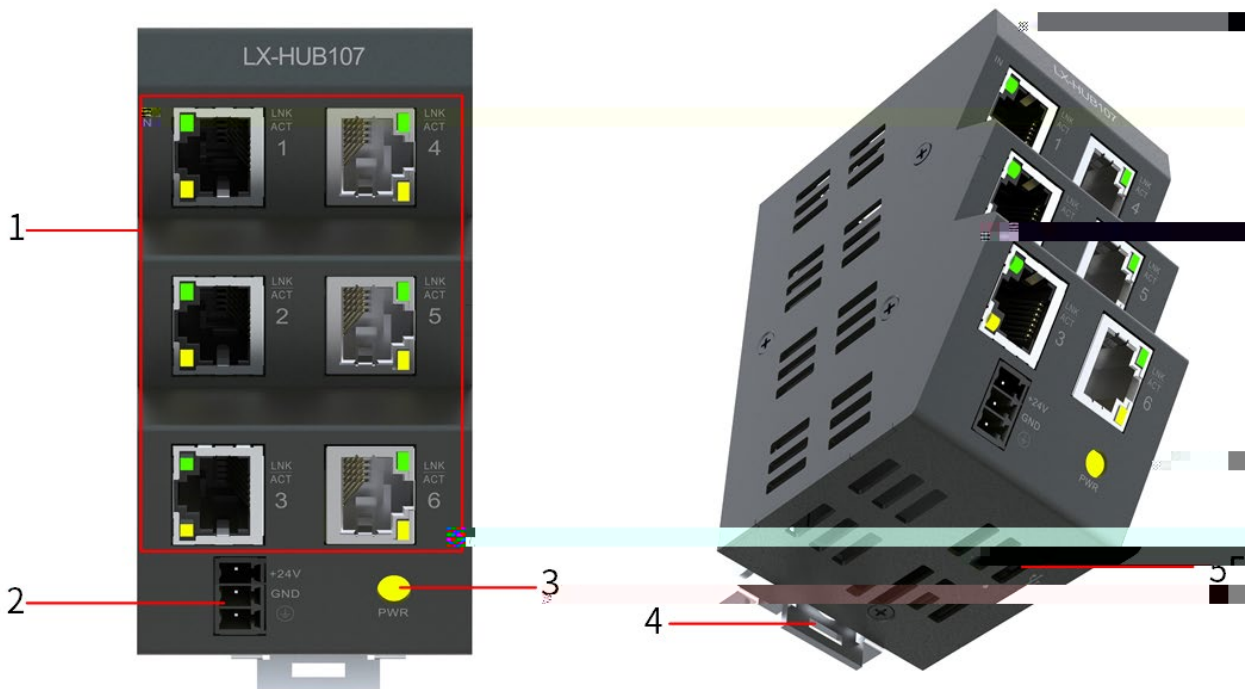

Schematic diagram of the LX-HUB107 module

Module component description table

S/N	Component Name	Instructions
-----	----------------	--------------

--	--	--

9.3.2 Technical Indicators

Item	Specifications

Item	Specifications
EtherCAT network port	
	1000VAC@1min@5mA, channel

9.3.3 Status Indicators

Definition of indicator lights

Color	Name	Status Description

9.3.4 Description of Wiring Terminal

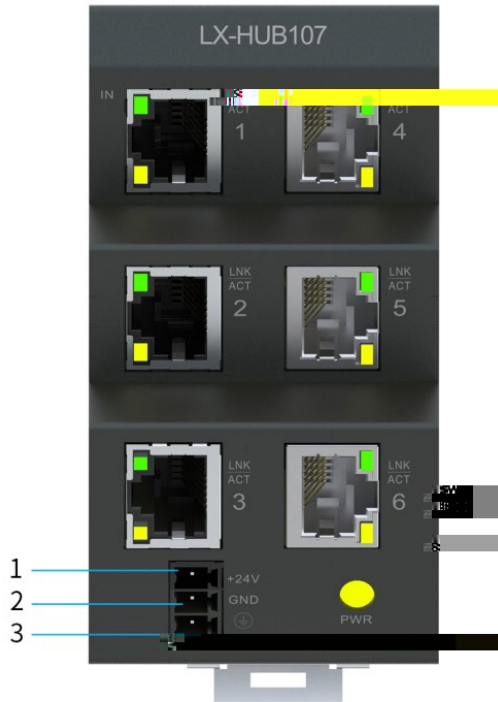

Schematic diagram of LX-HUB107 terminal component
Terminal definition explanation module terminal definition

Pin No.	Symbol	Meaning

Chapter 10 Coupler Module

LX Series Programmable Controller Communication Manual

10.1 LX-IM001 EtherCAT Coupler Module

10.1.1 Product Overview

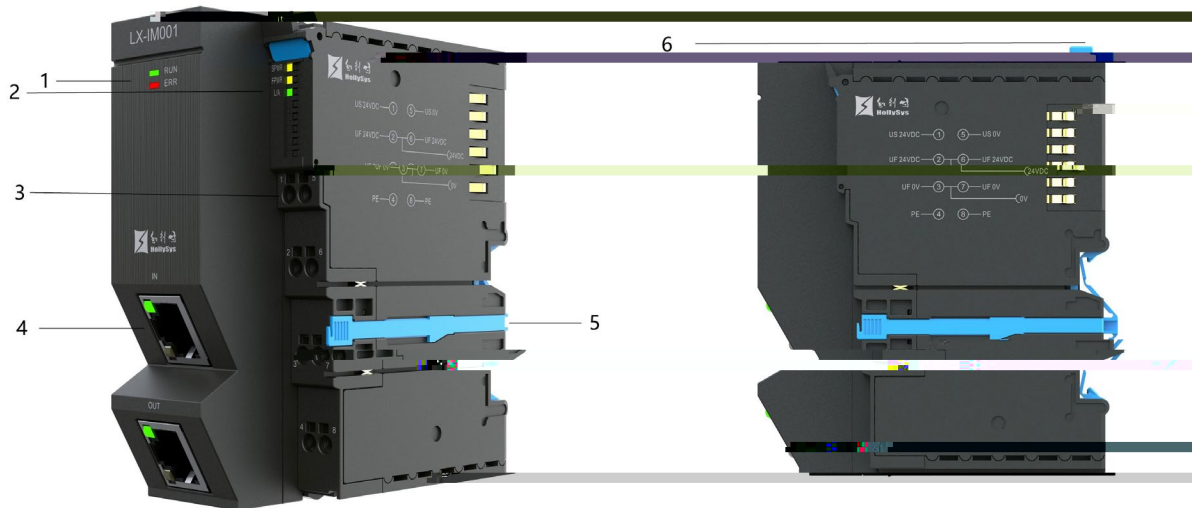

Schematic diagram of the LX-IM001 module

Module component description table

S/N	Component Name	Instructions



Nameplate schematic diagram

Nameplate information description table

S/N	Name	Meaning

10.1.2 Technical Indicators

Item	Specifications

Item	Specifications

Item	Specifications
LX-bus bus interface	
Control the network bus	
	100m
	1000VAC@1min@5mA

10.1.3 Status Indicators

Definition of indicator lights

Position	Name	Color	Status Description

--	--	--	--	--

10.1.5 Parameter specification

EtherCAT IO mapping channel system parameters description

Type	Parameters	Fault Name	Diagnostic Information
			ERR
			ERR

10.2 LX-IM002 EtherCAT End Coupler Module

10.2.1 Product Overview

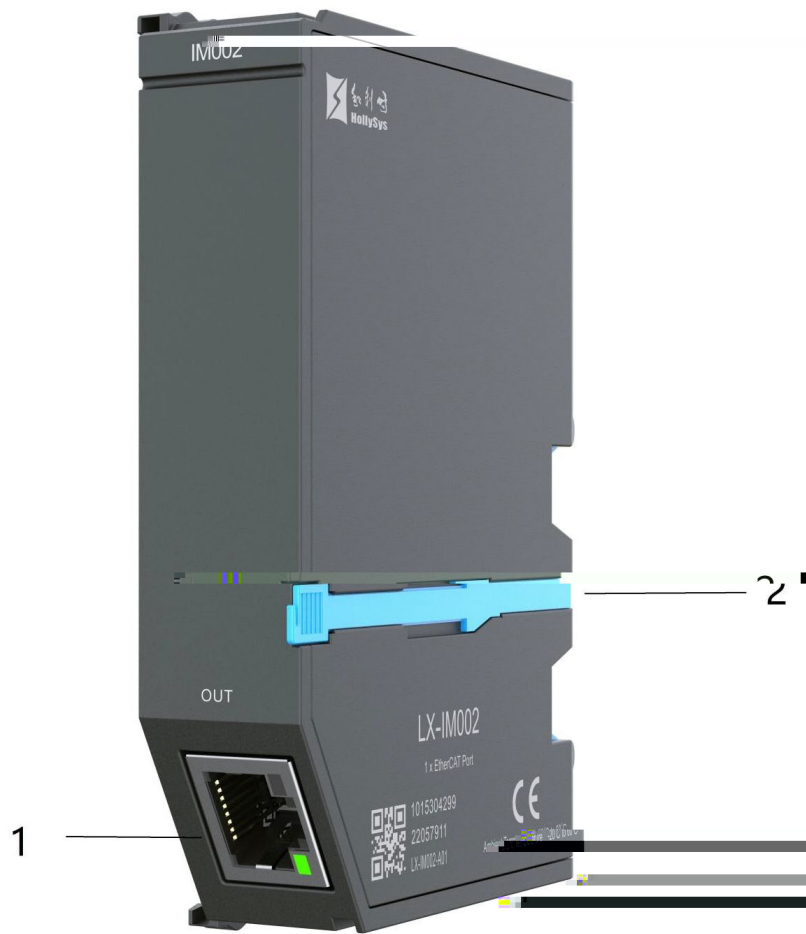

Schematic diagram of the LX-IM001 module

Module component description table

S/N	Component Name	Instructions

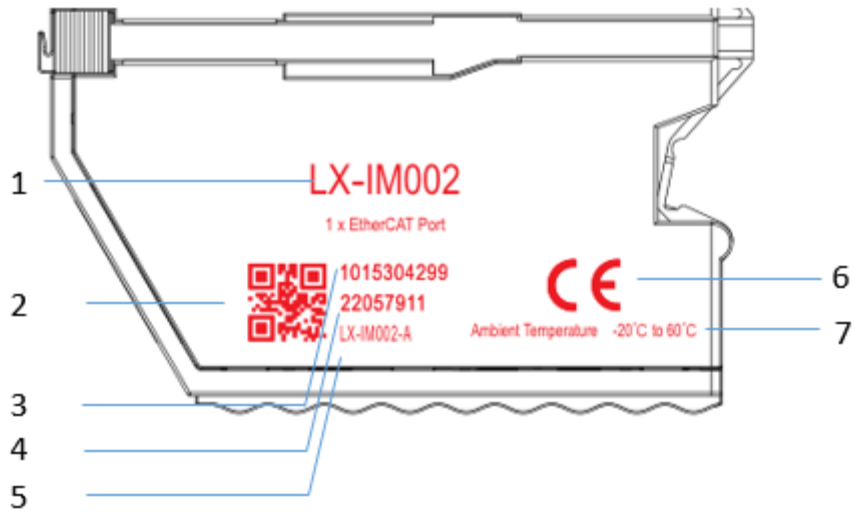

Nameplate schematic diagram

Nameplate information description table

S/N	Name	Meaning

10.2.2 Technical Indicators

Item	Specifications

Item	Specifications

Item	Specifications
Ethernet field bus	
	100m

10.2.3 Description of Terminal Components

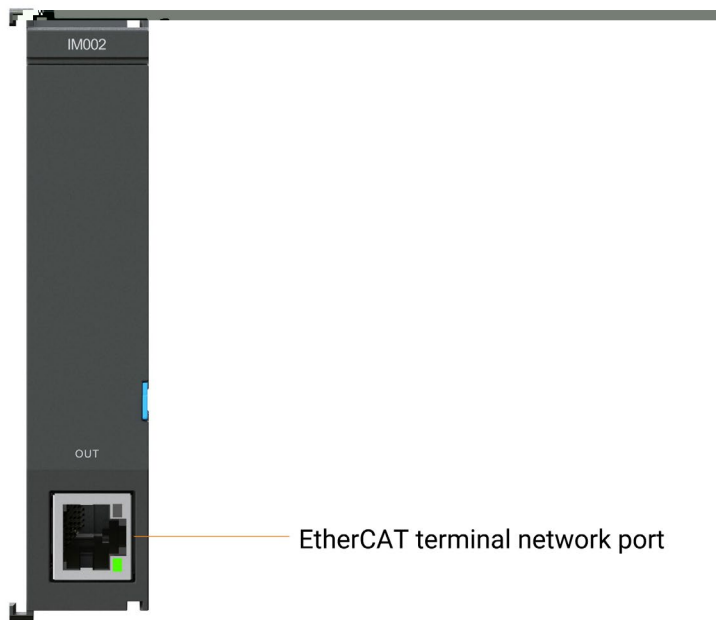

Chapter 11 IO Module

LX Series Programmable Controller Communication Manual

11.1

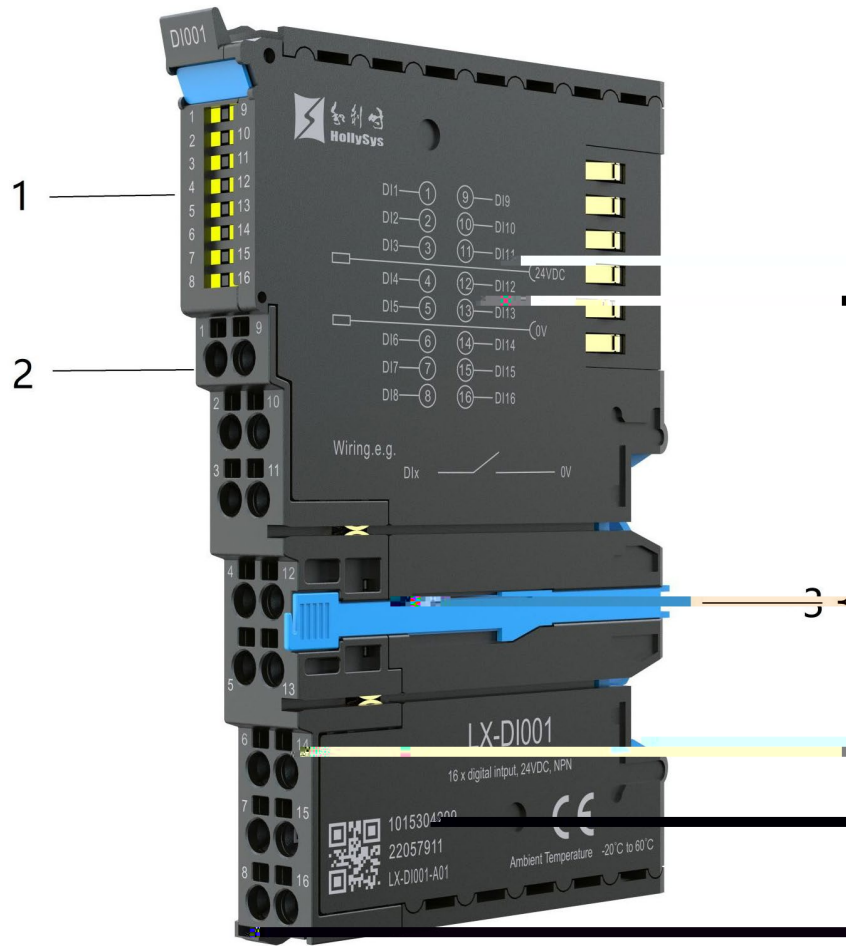

Schematic diagram of the LX-DI001 module
Module component description table

S/N	Component Name	Instructions

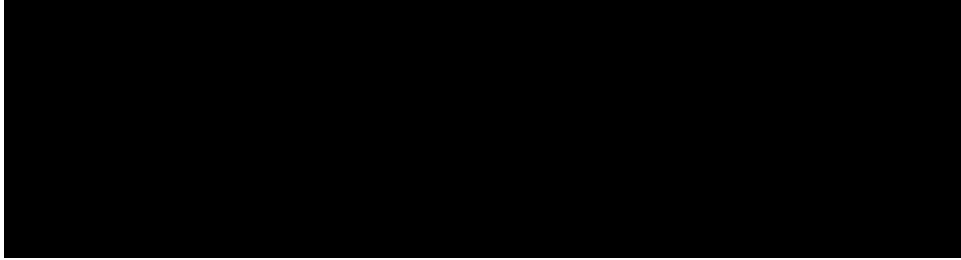

Nameplate schematic diagram

Nameplate information description table

S/N	Name	Meaning

11.1.1.2 Technical Indicators



Item	Specifications

11.1.1.6 Diagnostic Alarm

Module diagnostic instructions

S/N	Module Diagnosis	Object Dictionary	Instructions
-----	------------------	-------------------	--------------

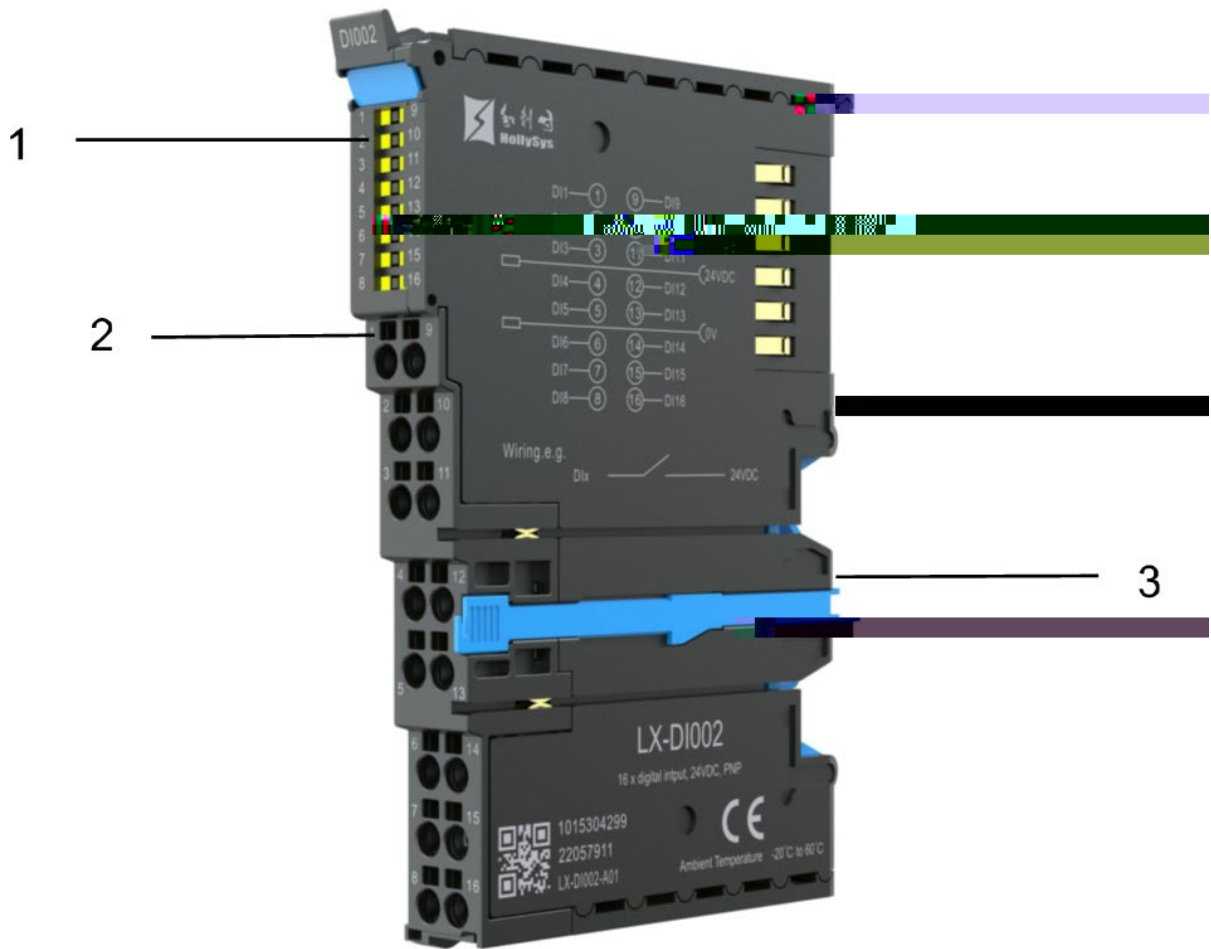

Schematic diagram of the LX-DI002 module

Module component description table

S/N	Component Name	Instructions



Nameplate schematic diagram

Nameplate information description table

S/N	Name	Meaning

11.1.2.2 Technical Indicators

Item	Specifications

Item	Specifications
	(

Item	Specifications

Item	Specifications

11.1.2.3 Status Indicators

LX-DI002 Indicator light status description table

Name		Color	Status Description

11.1.2.4 Description of Terminal Components

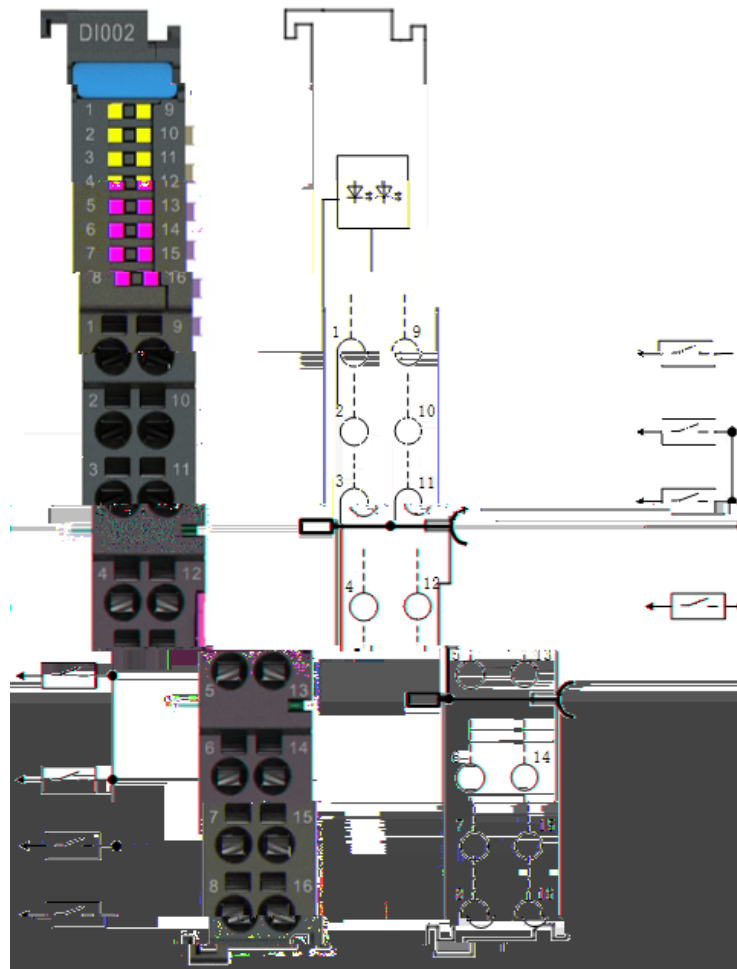

The definition of terminals

S/N	Description of Signals	Description	S/N	Description of Signals	Description

11.1.2.5 Parameter specification

Parameter description for DeviceNet slave

Channel Parameter Name	Parameter Meaning	Parameter Value	Default values

11.1.2.6 Diagnostic Alarm

Module diagnostic description table

S/N	Module Diagnosis	Object Dictionary	Instructions

11.1.3 LX-DI005 8-Channel 5 V DC Digital Input Module

11.1.3.1 Product Overview

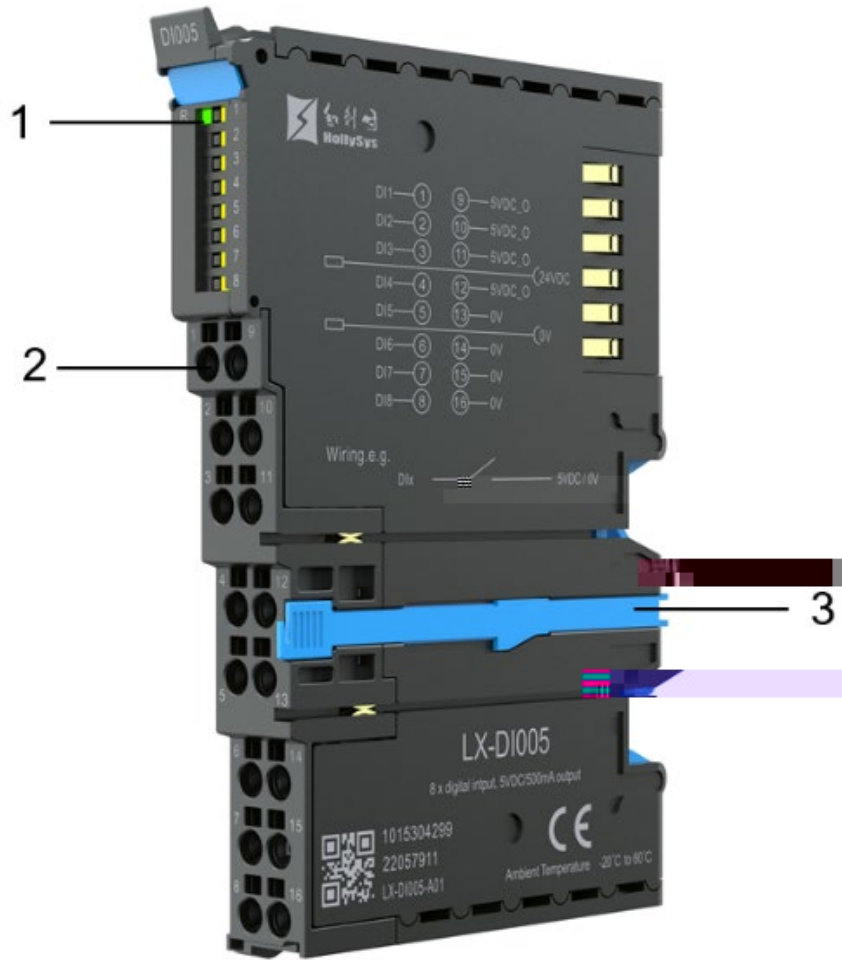

Schematic diagram of the LX-DI005 module
Module component description table

S/N	Component Name	Instructions

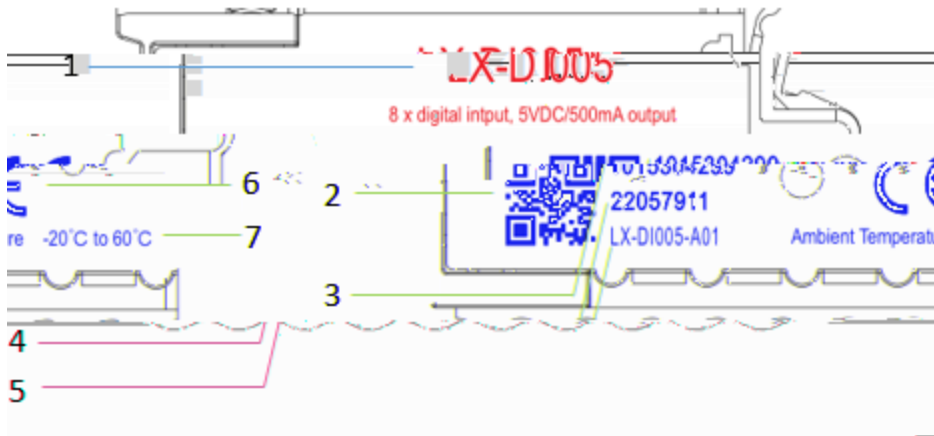

Nameplate schematic diagram

Nameplate information description table

S/N	Name	Meaning

11.1.3.2 Technical Indicators

Item	Specifications

Item	Specifications
System power supply	
On-site power output	

Item	Specifications

The definition of terminals

S/N	Description of Signals	Description	S/N	Description of Signals	Description

11.1.3.6 Diagnostic Alarm

The diagnostic information

Type	Parameters	Fault Name	Diagnostic Information

The description of module diagnos

S/N	Type	Object Dictionary	Instructions

11.2 DO Module

11.2.1 LX-DO004 4-channel Relay Type Digital Output Module

11.2.1.1 Product Overview

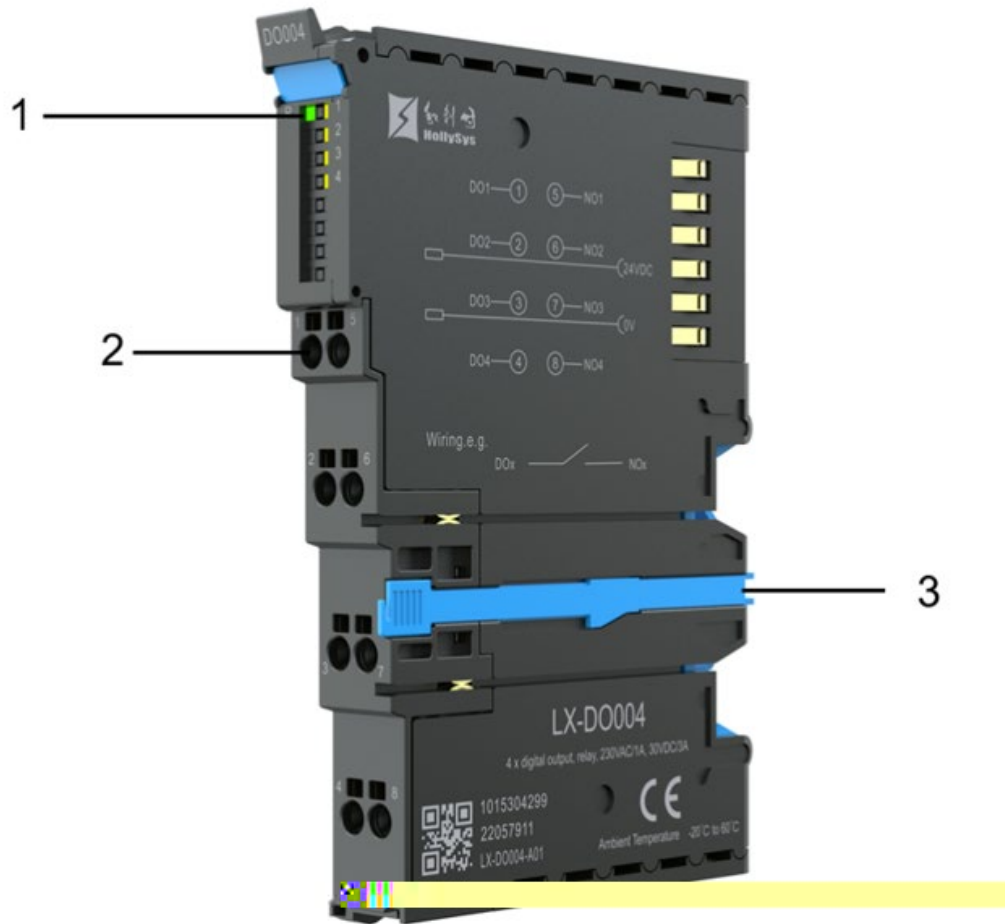

Schematic diagram of the LX-DO004 module

Module component description table

S/N	Component Name	Instructions

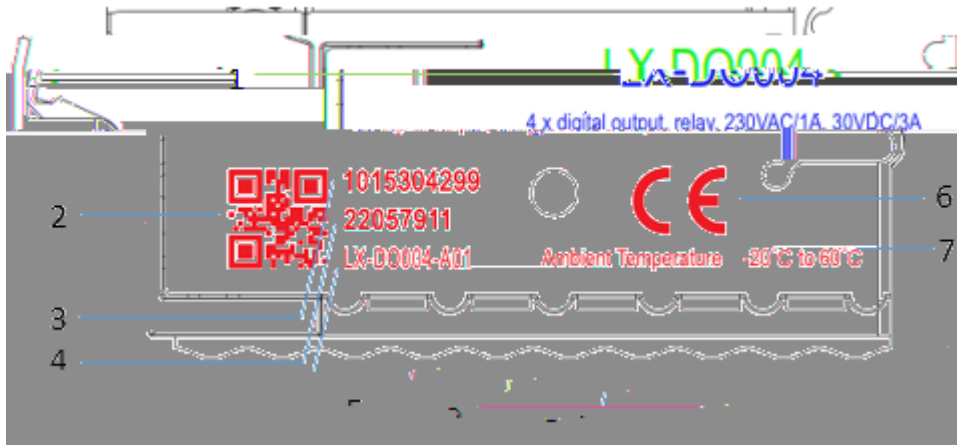

Nameplate schematic diagram

Nameplate information description table

S/N	Name	Meaning

11.2.1.2 Technical Indicators

Item	Specifications

Item	Specifications
	(

Item	Specifications
------	----------------

Item	Specifications

11.2.1.3 Status Indicators

Name	Color	Status Description

11.2.1.4 Description of Terminal Components

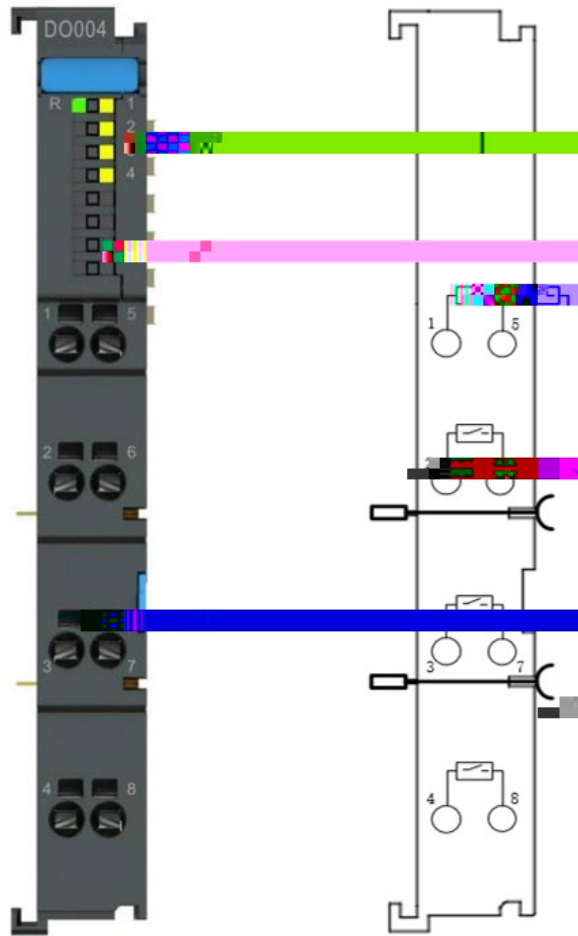

The definition of terminals

Pin No.	Symbol	Meaning	Pin No.	Symbol	Meaning

11.2.1.6 Diagnostic Alarm

S/N	Module Diagnosis	Object Dictionary	Instructions

11.2.2 LX-DO005 8-channel 5 V DC Digital Output Module

11.2.2.1 Product Overview

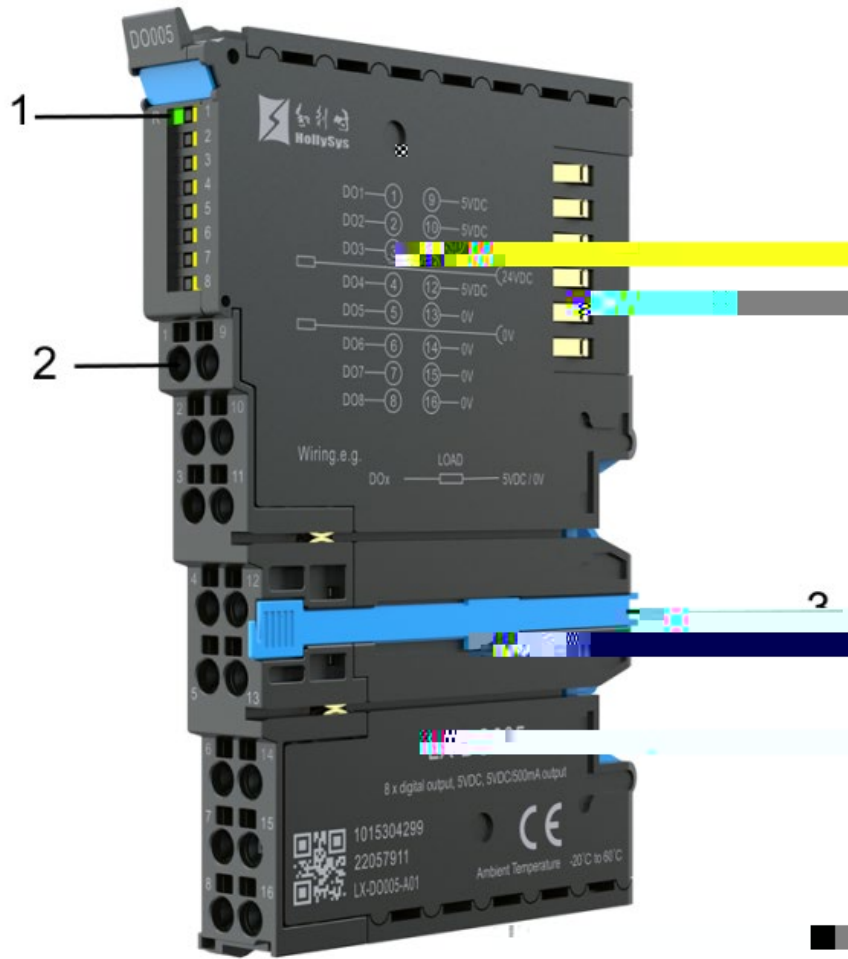

Schematic diagram of the LX-DO005 module

Module component description table

S/N	Component Name	Instructions

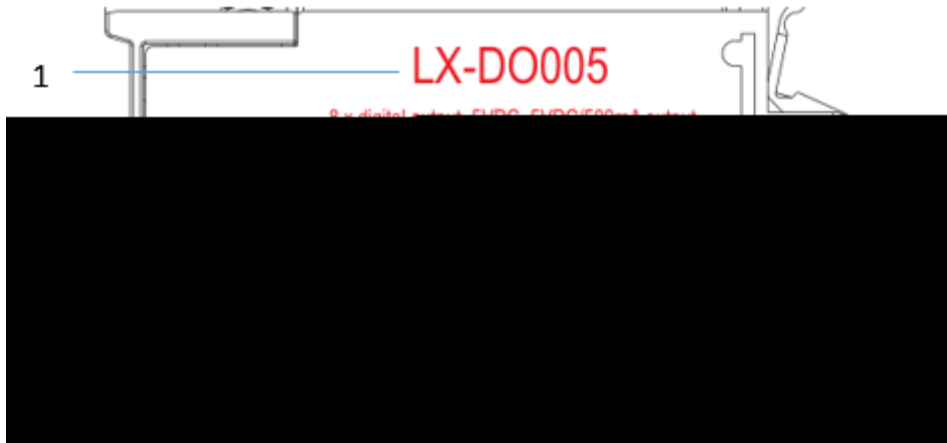

Nameplate schematic diagram

Nameplate information description table

S/N	Name	Meaning

11.2.2.2 Technical Indicators

Item	Specifications

Item	Specifications
System power supply	
Field power output	

--	--

Item	Specifications

Item	Specifications

11.2.2.3 Status Indicators

Name	Color	Status Description

11.2.2.4 Description of Terminal Components

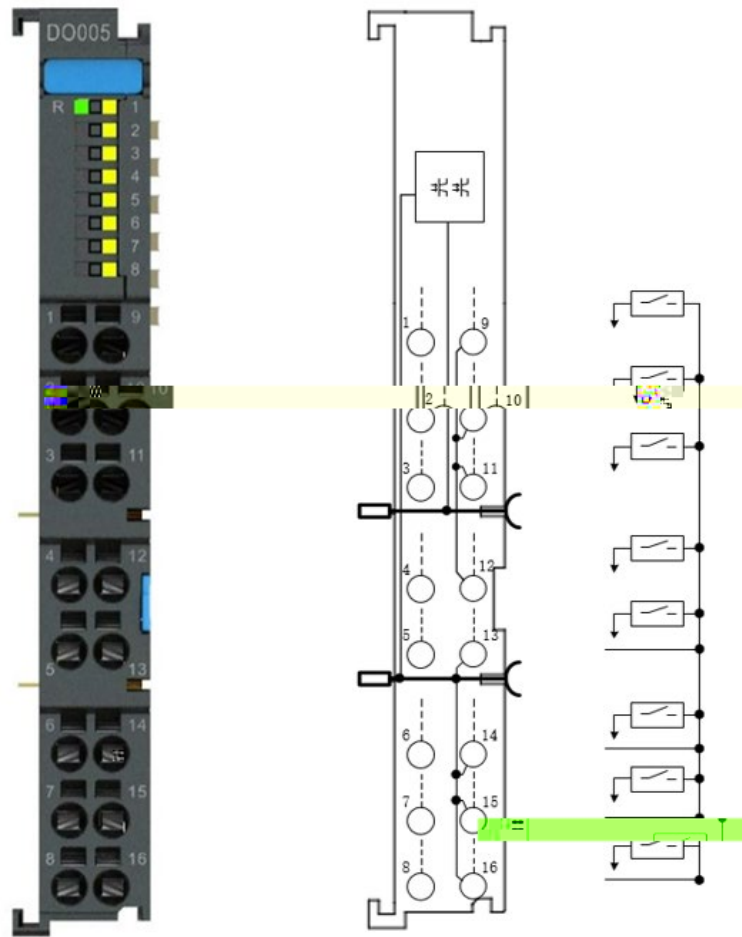

The definition of terminals

S/N	Description of Signals	Description	S/N	Description of Signals	Description

11.2.2.5 Parameter specification

Parameter description for DeviceNet slave

Channel	Parameter Name	Parameter Meaning	Parameter Value	Default value

EtherCAT IO mapping channel data

Channel Parameter Name	Parameter Meaning	Parameter Value

11.2.2.6 Diagnostic Alarm

S/N	Module Diagnosis	Object Dictionary	Instructions

11.2.3 LX-DO003 16-Channel 24 V DC Digital Output Module

11.2.3.1 Product Overview

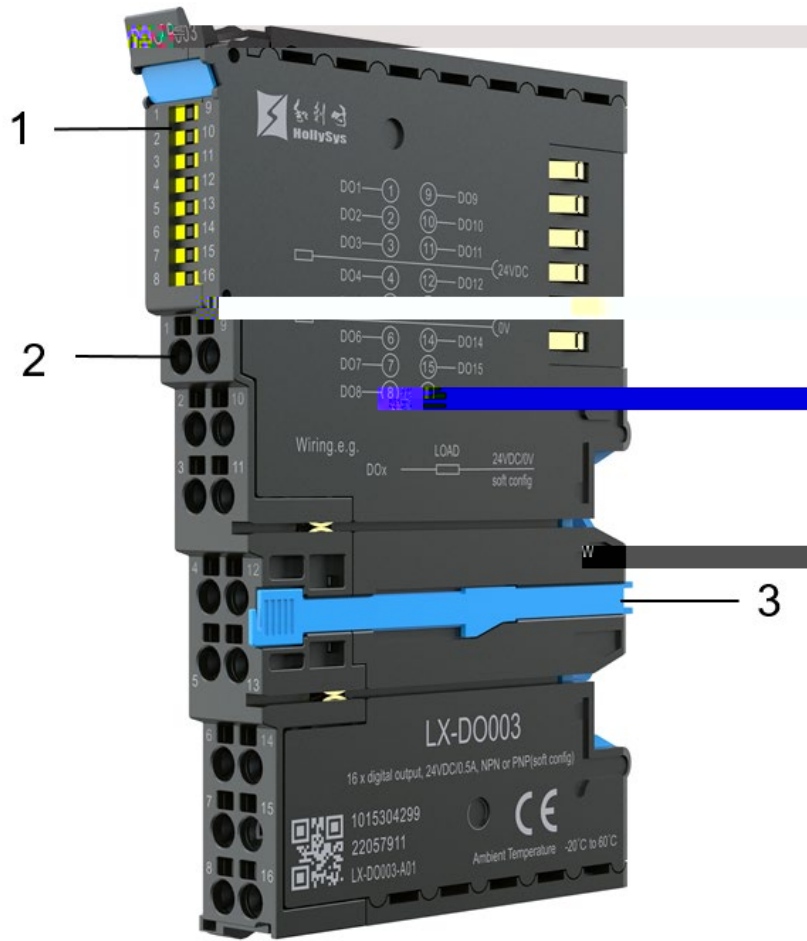

Schematic diagram of the LX-DO003 module

Module component description table

S/N	Component Name	Instructions

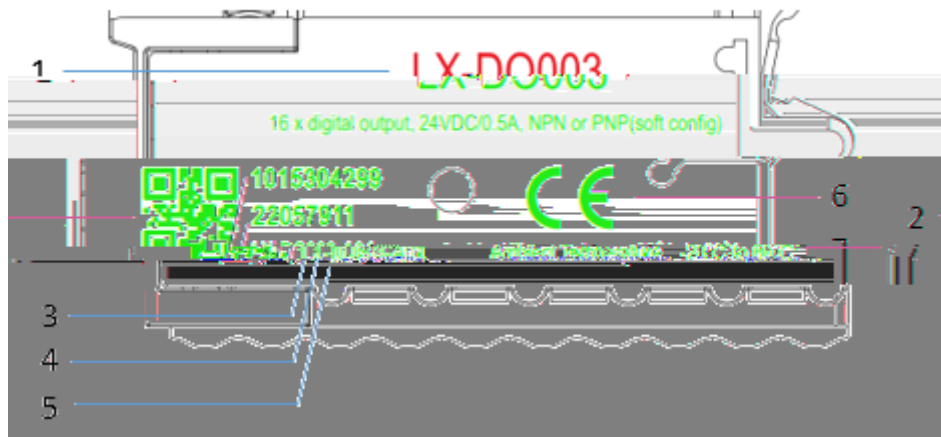

Nameplate schematic diagram

Nameplate information description table

S/N	Name	Meaning



The definition of terminals

S/N	Description of Signals	Description	S/N	Description of Signals	Description

-
-
-
-

11.2.3.5 Parameter specification

Parameter description for DeviceNet slave

Channel Parameter Name	Parameter Meaning	Parameter Value	Default value

11.2.3.6 Diagnostic Alarm

S/N	Module Diagnosis	Object Dictionary	Instructions

11.3 Counting Module

11.3.1 LX-ECI001 2-channel Incremental Encoder Input Module

11.3.1.1 Product Overview

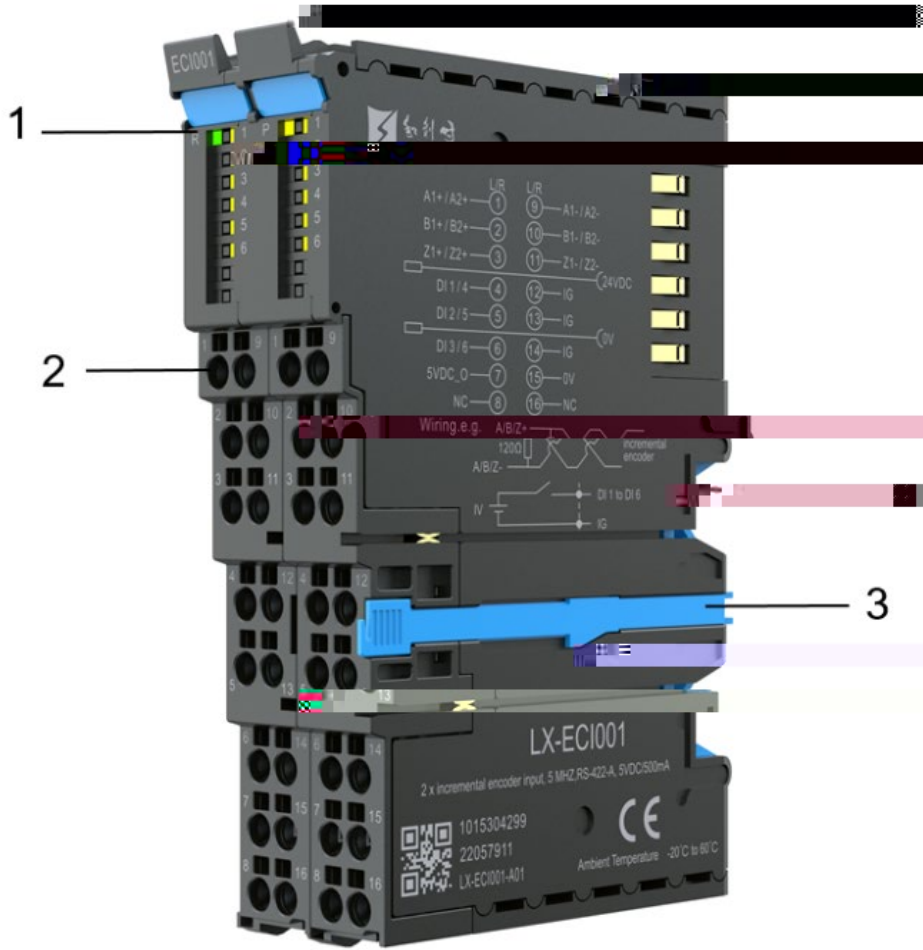

Schematic diagram of the LX-ECI001 module

Module component description table

S/N	Component Name	Instructions

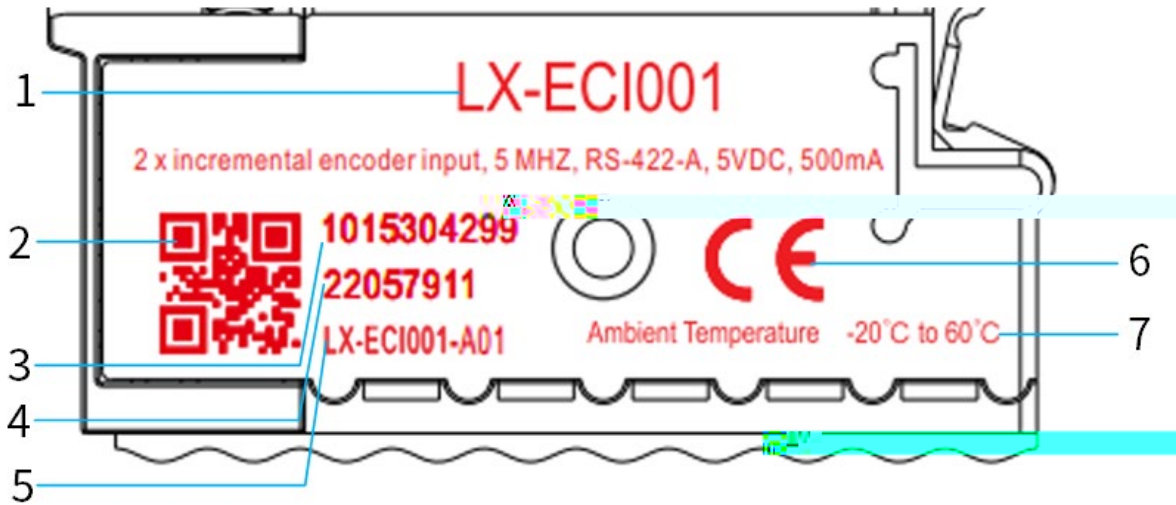

Nameplate schematic diagram

Nameplate information description table

S/N	Name	Meaning

11.3.1.2 Technical Indicators

Item	Specifications

Item	Specifications
Power supply	
Power output	

On-site power supply	

Item	Specifications
Channel	
	120 typ
Digital input channel	

-
- The typical input impedance is 120 Ω , and values within the range of 100 Ω - 140 Ω are normal.
-

•

11.3.1.3 Status Indicators

Color	Name	Meaning

Color	Name	Meaning

11.3.1.4 Description of Terminal Components

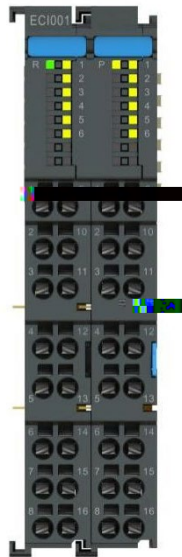

The definition of terminals Pe

Pin No.	Symbol	Meaning	Pin No.	Symbol	Meaning

11.3.2 LX-ECI002 2-channel 24V incremental encoder input module

11.3.2.1 Product Overview

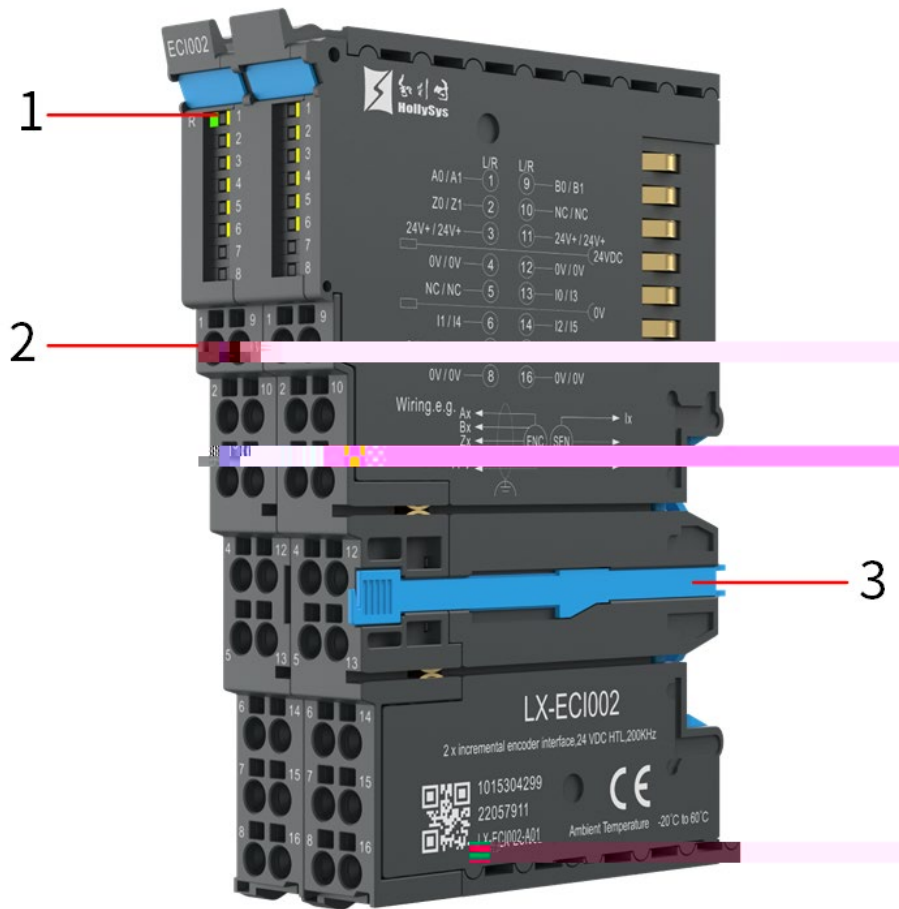

Schematic diagram of the LX-ECI002 module
Module component description table

S/N	Component Name	Instructions

11.3.2.2 Technical Indicators

Item	Specifications

11.3.2.3 Status Indicators

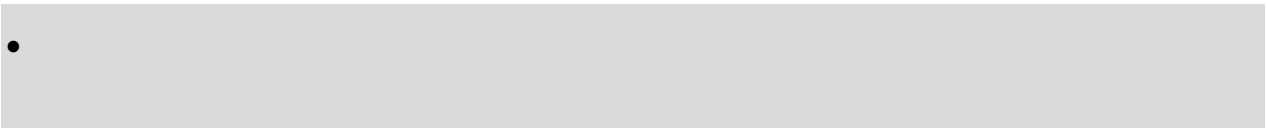

Definitions of left-side indicators

Color	Name	Meaning

Definitions of right-side indicators

Color	Name	Meaning

11.3.2.4 Description of Terminal Components

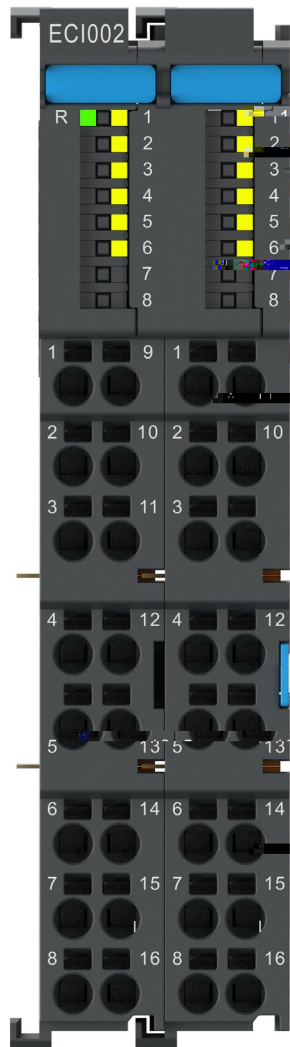

The definition of terminals 10

Pin No.	Symbol	Meaning	Pin No.	Symbol	Meaning

Position Latching Explanation

Bit	Value	Definition
0	0	Switch off touch probe 1
	1	Enable touch probe 1
1	0	Trigger first event
	1	continuous
2	0	Trigger with touch probe 1 impulse signal or position encoder
	1	Trigger with zero impulse signal or position encoder
3	0	Reserved
	1	Switch off sampling at positive edge of touch probe 1
4	0	Switch off sampling at negative edge of touch probe 1
	1	Enable sampling at positive edge of touch probe 1
5	0	Switch off sampling at negative edge of touch probe 1
	1	Enable sampling at negative edge of touch probe 1
6, 7	-	User-defined (e.g. for testing)
	-	-
8	0	Switch off touch probe 2
	1	Enable touch probe 2
9	0	Trigger first event of touch probe 2
	1	Continuous
10	0	Trigger with touch probe 2 impulse signal or position encoder
	1	Trigger with zero impulse signal or position encoder
11	0	Reserved
	1	Switch off sampling at positive edge of touch probe 2
12	0	Switch off sampling at negative edge of touch probe 2
	1	Enable sampling at positive edge of touch probe 2
13	0	Switch on sampling at negative edge of touch probe 2
	1	Enable sampling at negative edge of touch probe 2
14, 15	-	User-defined (e.g. for testing)
	-	-

Bit	Value	Definition
0	0	Touch probe 1 is switched off
	1	Touch probe 1 is enabled
1	0	Touch probe 1 no positive edge position stored
	1	Touch probe 1 positive edge position stored
2	0	Touch probe 1 no negative edge value stored
	1	Touch probe 1 negative edge value stored
3 to 5	0	Reserved
6, 7	-	User-defined (e.g. for testing)
8	0	Touch probe 2 is switched off
	1	Touch probe 2 is Enabled
9	0	Touch probe 2 no positive edge position stored
	1	Touch probe 2 positive edge position stored
10	0	Touch probe 2 no negative edge value stored
	1	Touch probe 2 negative edge value stored

11.4 Encoder Module

11.4.1 LX-SSI001 2-Channel SSI Absolute Encoder Module

11.4.1.1 Product Overview

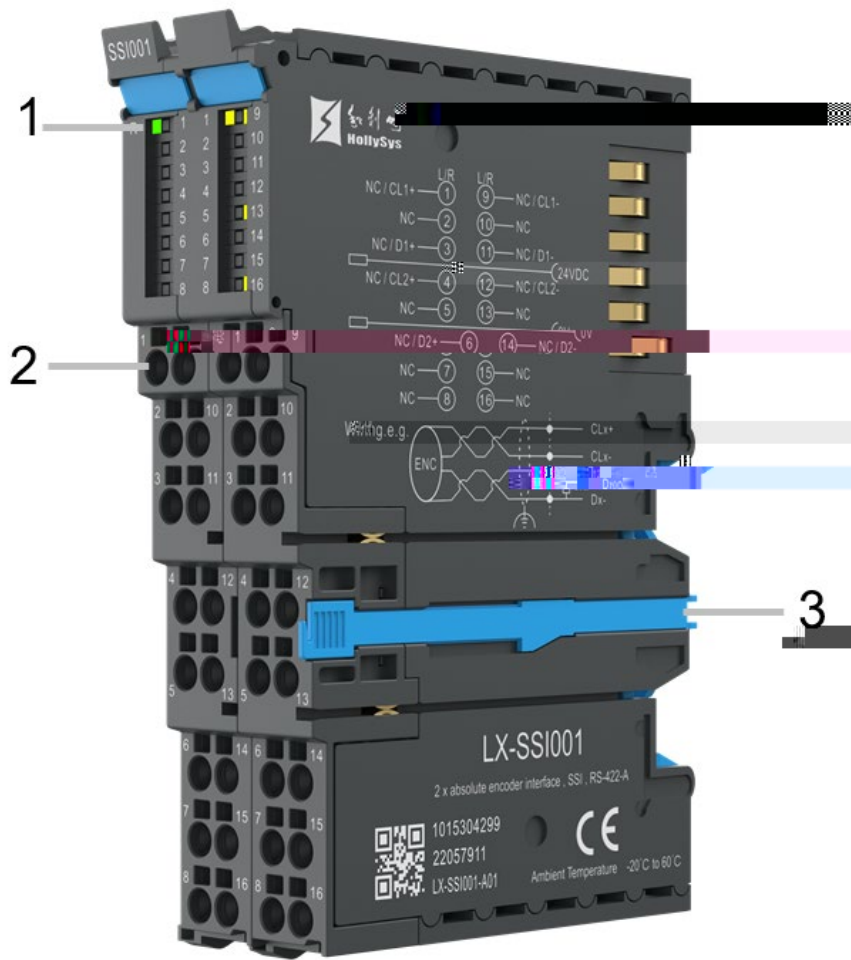

Schematic diagram of the LX-SSI001 module
Module component description table

S/N	Component Name	Instructions

Nameplate schematic diagram
Nameplate information description table

S/N	Name	Meaning

11.4.1.2 Technical Indicators

Item	Specifications

Item	Specifications
Power supply	
Supply	

11.4.1.4 Description of Terminal Components

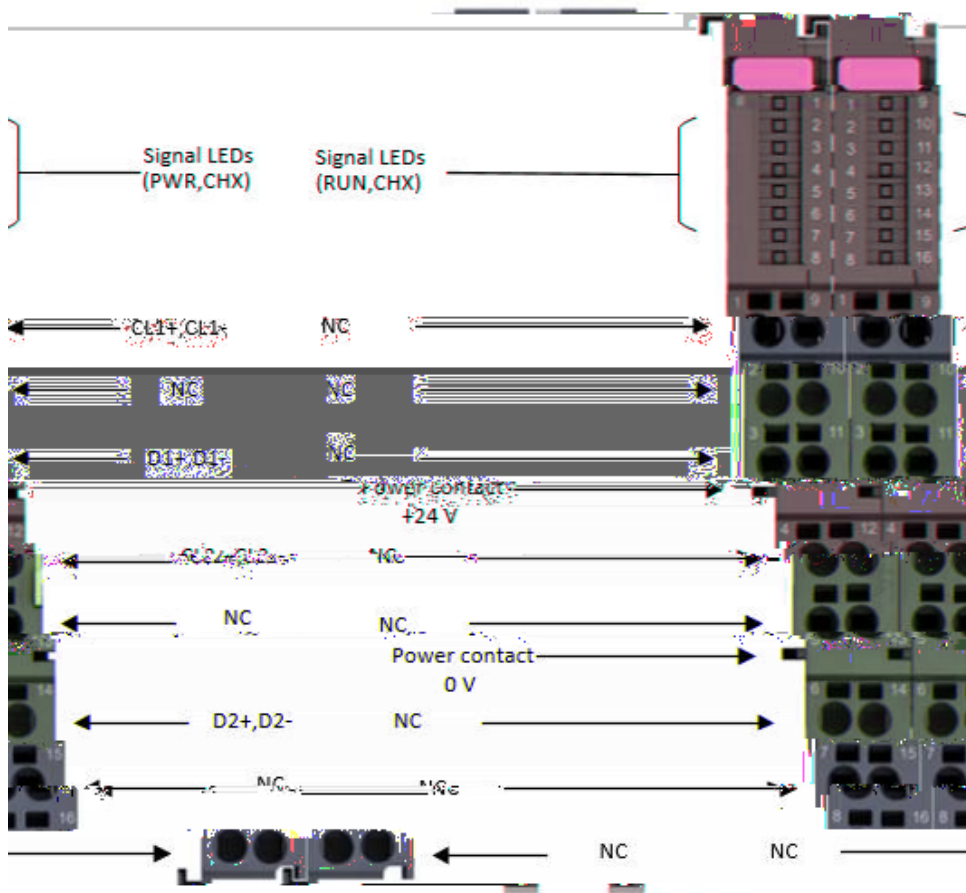

The definition of terminals

Pin No.	Symbol	Meaning	Pin No.	Symbol	Meaning
Pin No.	Symbol	Meaning	Pin No.	Symbol	Meaning

--	--

11.4.1.6 Diagnostic Alarm

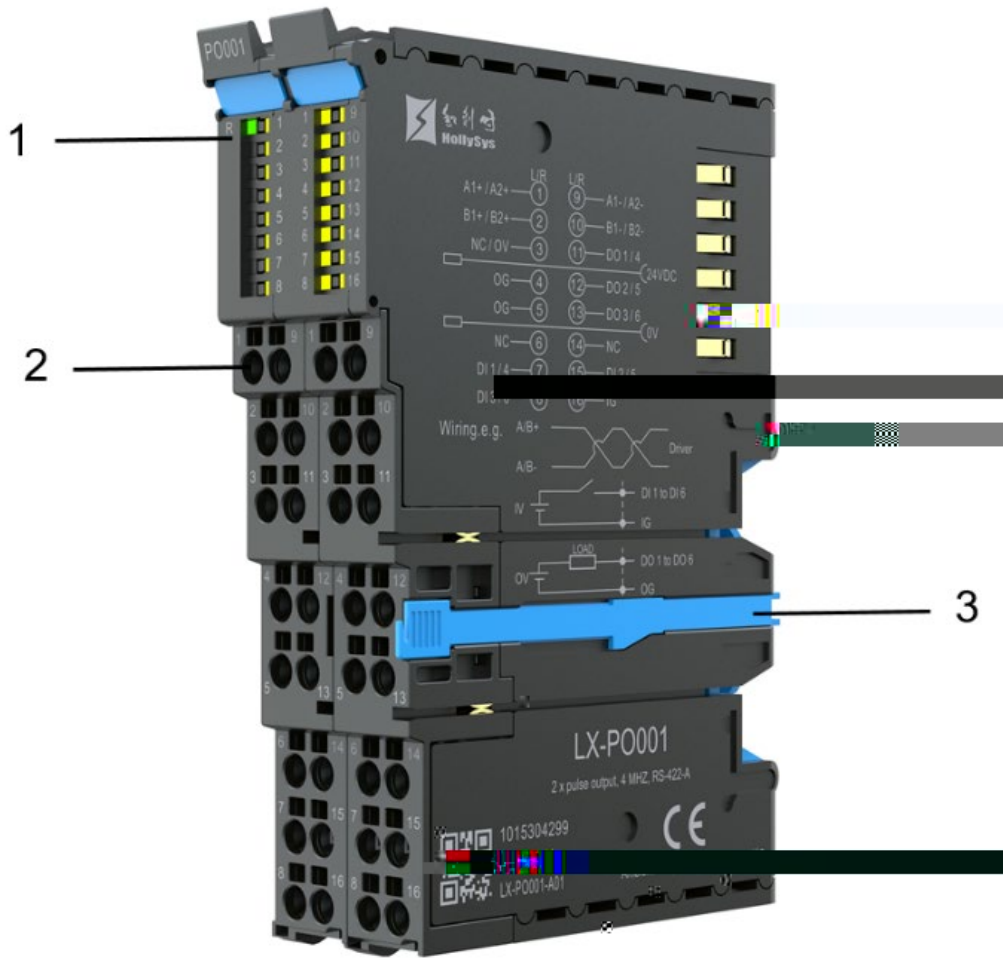

Schematic diagram of the LX-PO001 module

Module component description table

S/N	Component Name	Instructions

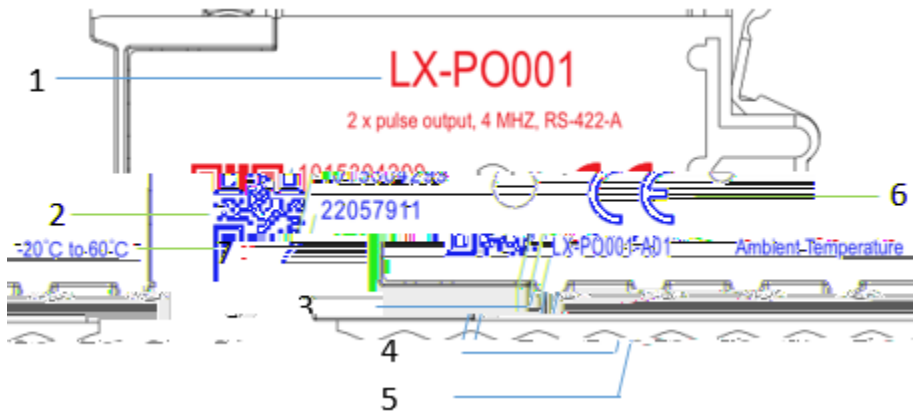

Nameplate schematic diagram

Nameplate information description table

S/N	Name	Meaning

11.5.1.2 Technical Indicators

Item	Specifications

Item	Specifications
Power supply	
Field power	

Item	Specifications

	EIA standard RS-422-A
	PLS+DIR (default), CW/CCW,A/B phase pulse output 1x frequency

Color	Name	Meaning

11.5.1.4 Description of Terminal Components

The definition of terminals

Pin No.	Symbol	Meaning	Pin No.	Symbol	Meaning
Pin No.	Symbol	Meaning	Pin No.	Symbol	Meaning

11.5.1.5 Parameter specification

Parameter description for DeviceNet slave

Configuration Parameters	Function Description	Parameter Range	Description
--------------------------	----------------------	-----------------	-------------

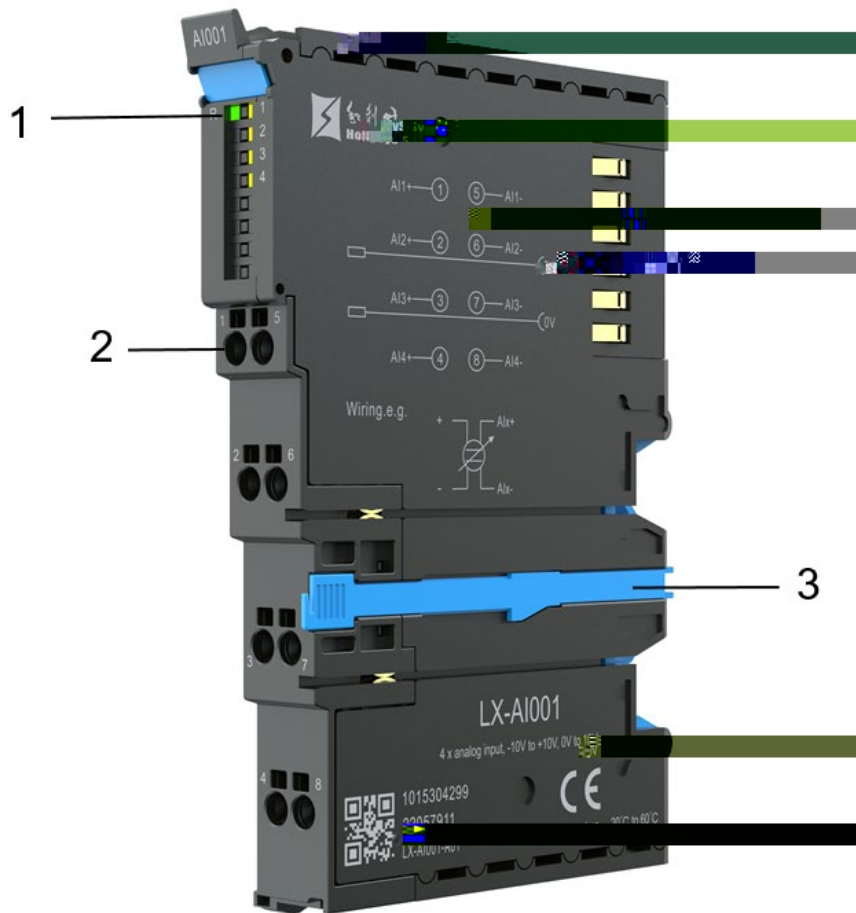

Schematic diagram of the LX-AI001 module

Module component description table

S/N	Component Name	Instructions

--	--	--

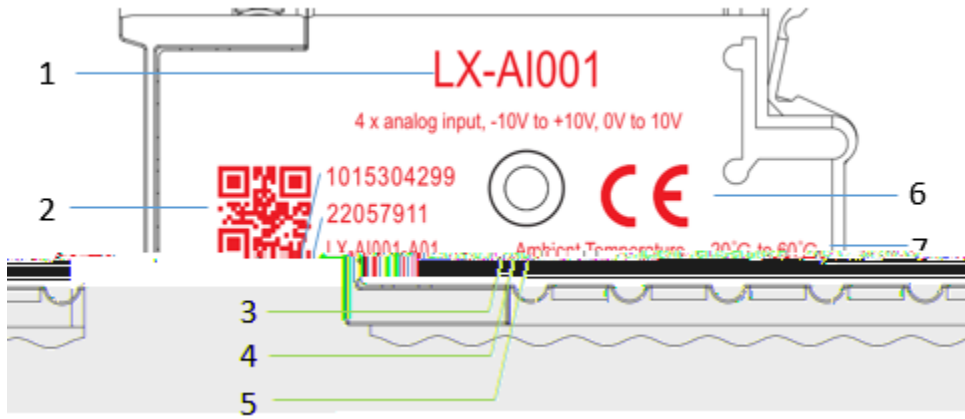

Nameplate schematic diagram

Nameplate information description table

S/N	Name	Meaning

11.6.1.2 Technical Indicators

Item	Specifications

Item	Specifications
------	----------------

Item	Specifications

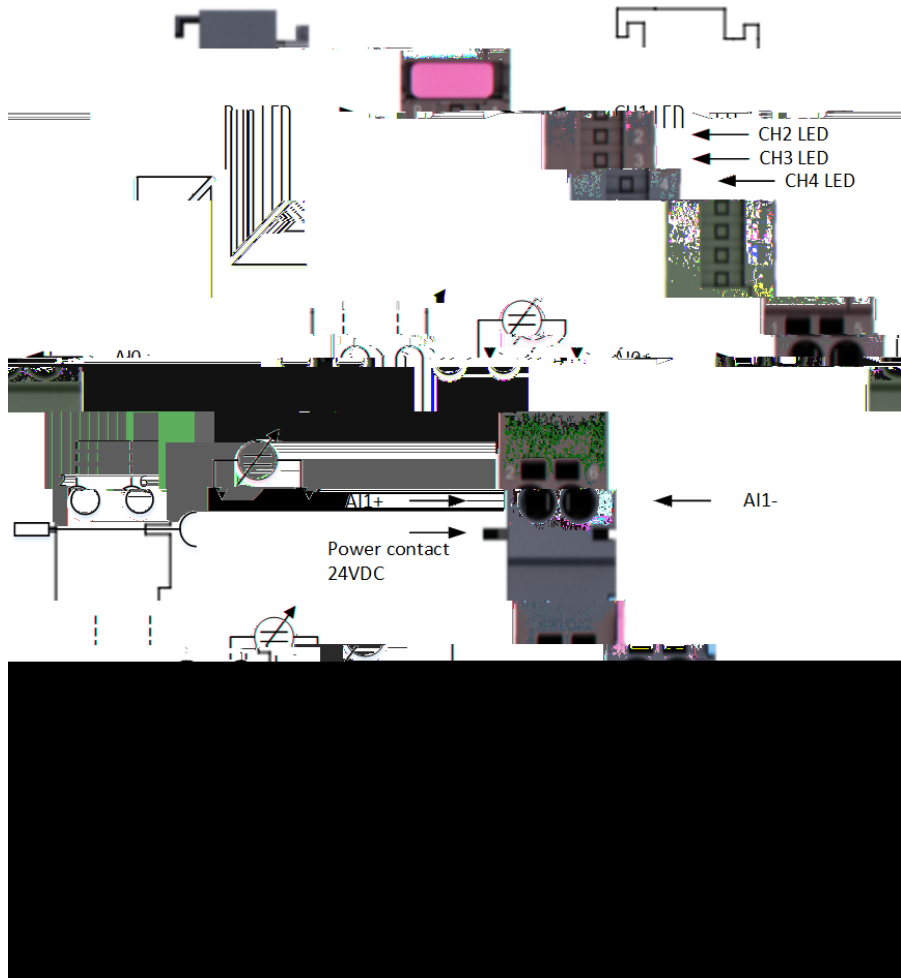

The definition of terminals

S/N	Description of Signals	Description	S/N	Description of Signals	Description

EtherCAT IO mapping channel data

Channel Parameter Name	Parameter Meaning	Parameter Value



11.6.1.6 Diagnostic Alarm

Description of diagnostic information

Type	Parameters	Fault Name	Diagnostic Information

11.6.2 LX-AI002 8-channel Voltage Type Analog Input Module

11.6.2.1 Product Overview

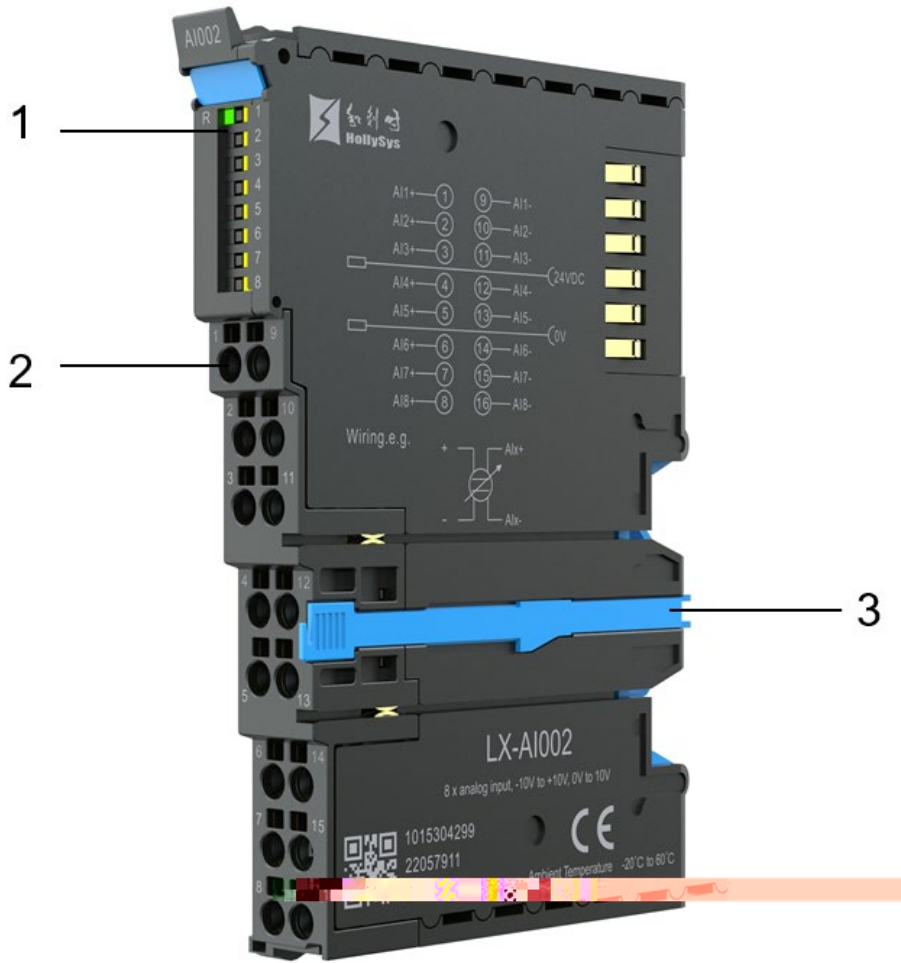

Schematic diagram of the LX-AI002 module

Module component description table

S/N	Component Name	Instructions

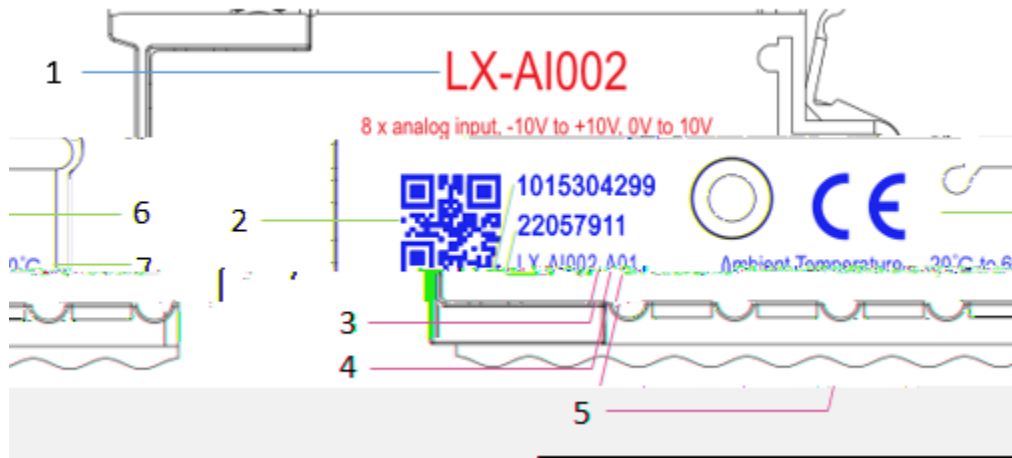

Nameplate schematic diagram

Nameplate information description table

S/N	Name	Meaning

--	--	--

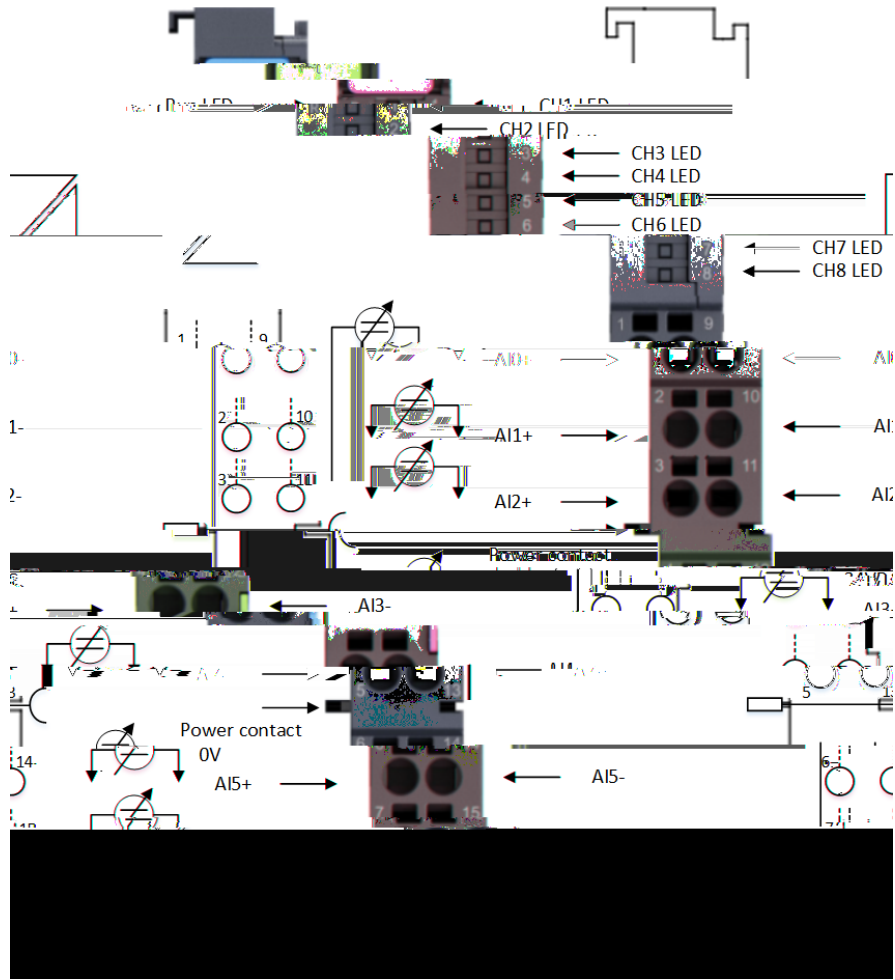

The definition of terminals

S/N	Description of Signals	Description	S/N	Description of Signals	Description

EtherCAT IO mapping channel data

Channel Parameter Name	Parameter Meaning	Parameter Value

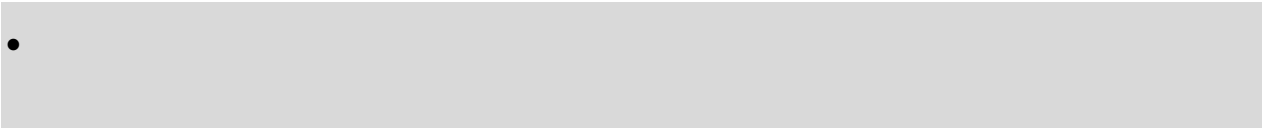

11.6.2.6 Diagnostic Alarm

The description of diagnostic information

Type	Parameters	Fault Name	Diagnostic Information

11.6.3

Module component description table

S/N	Component Name	Instructions

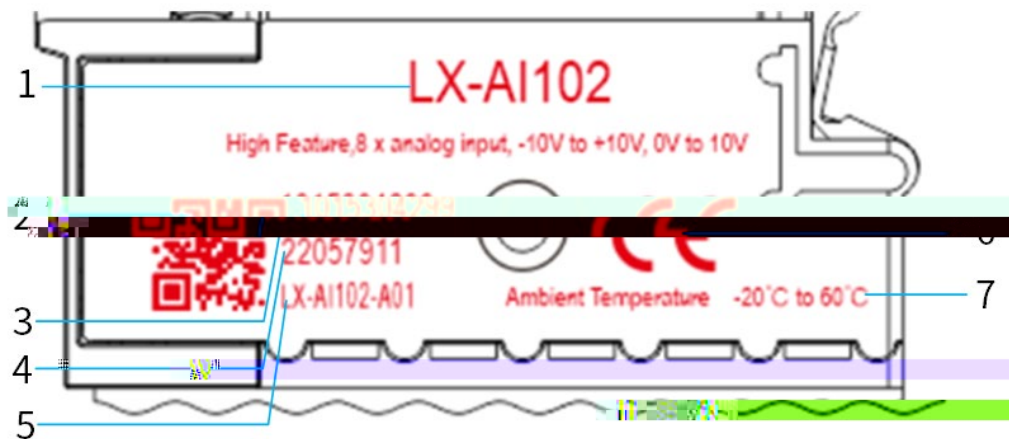

Nameplate schematic diagram

Nameplate information description table

S/N	Name	Meaning

11.6.3.2 Technical Indicators

Item	Specifications

Item	Specifications

Item	Specifications

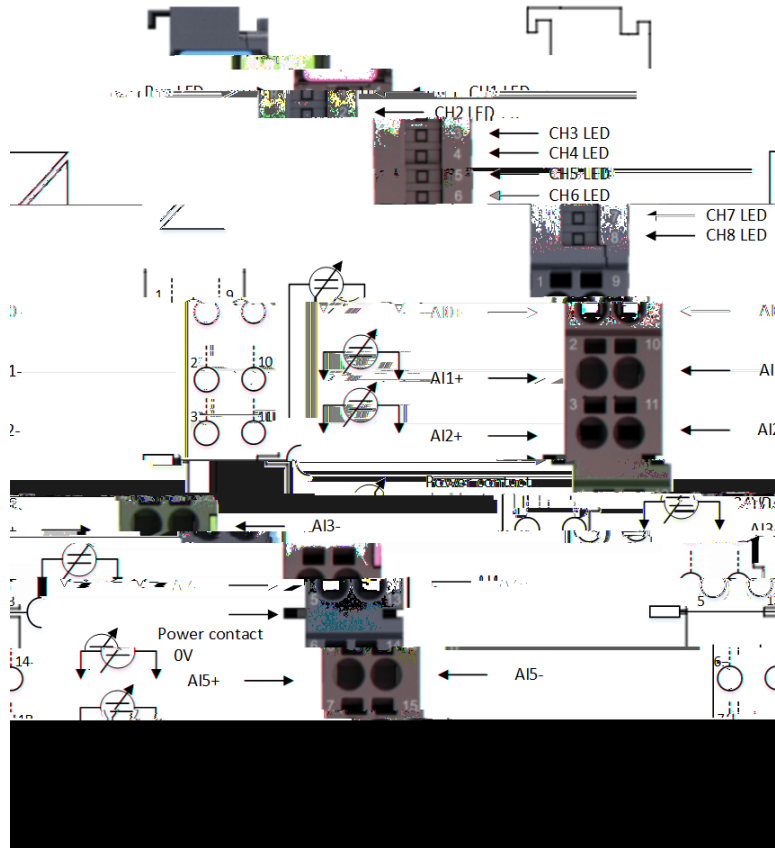

The definition of terminals

S/N	Description of Signals	Description	S/N	Description of Signals	Description

11.6.3.5 Parameter specification

Parameter description for DeviceNet slave

Configuration Parameters	Function Description	Parameter Range	Configuration Description (Default)

EtherCAT IO mapping channel data

Channel Parameter Name	Parameter Meaning	Parameter Value

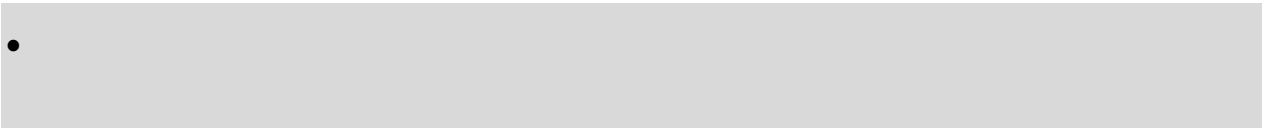

11.6.3.6 Diagnostic Alarm

The description of diagnostic information

Type	Parameters	Fault Name	Diagnostic Information

11.6.4 LX-AI003 4-channel Current Type Analog Input Module

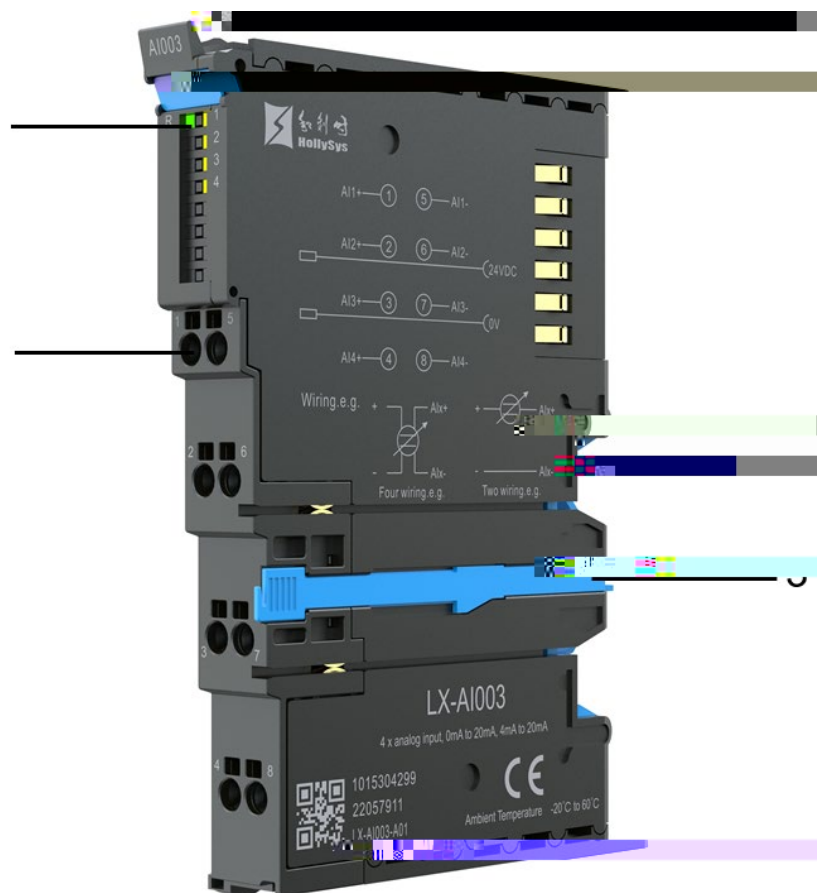

Schematic diagram of the LX-AI003 module
Module component description table

Instructions

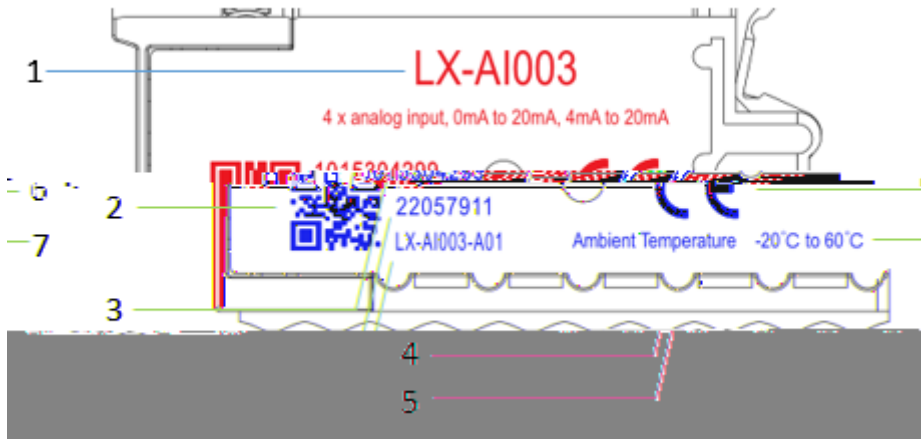

Nameplate schematic diagram

Nameplate information description table

S/N	Name	Meaning

11.6.4.1 Technical Indicators

Item	Specifications

Item	Specifications

Item	Specifications

		330μs/channel
		250±1

11.6.4.2 Status Indicators

Name	Color	Status Description

11.6.4.3 Description of Terminal Components

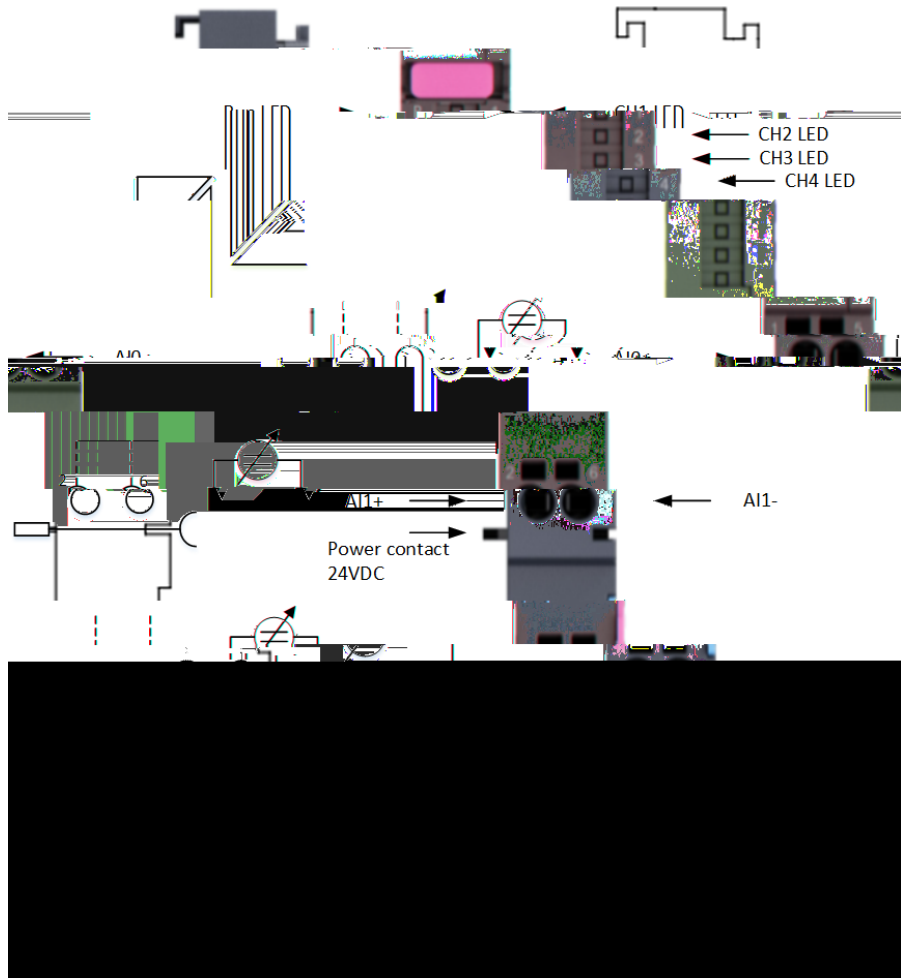

the definition of terminals

S/N	Description of Signals	Description	S/N	Description of Signals	Description

11.6.4.4 Parameter specification

Parameter description for DeviceNet slave

Configuration Parameters	Function Description	Parameter Range	Configuration Description (Default)

EtherCAT IO mapping channel data

Channel Parameter Name	Parameter Meaning	Parameter Value

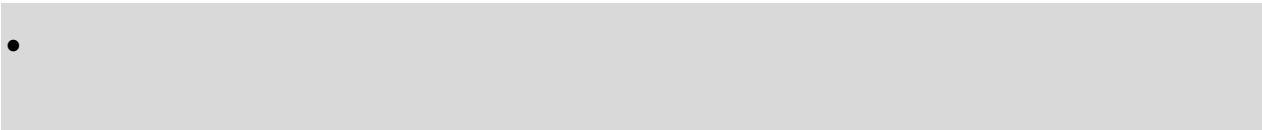

11.6.4.5 Diagnostic Alarm

Description of diagnostic information

Type	Parameters	Fault Name	Diagnostic Information

11.7 RTD Module

11.7.1 LX-RTD001 4-channel RTD Analog Input Module

11.7.1.1 Product Overview

Supports resistance range of 10 Ω to 4k Ω ;

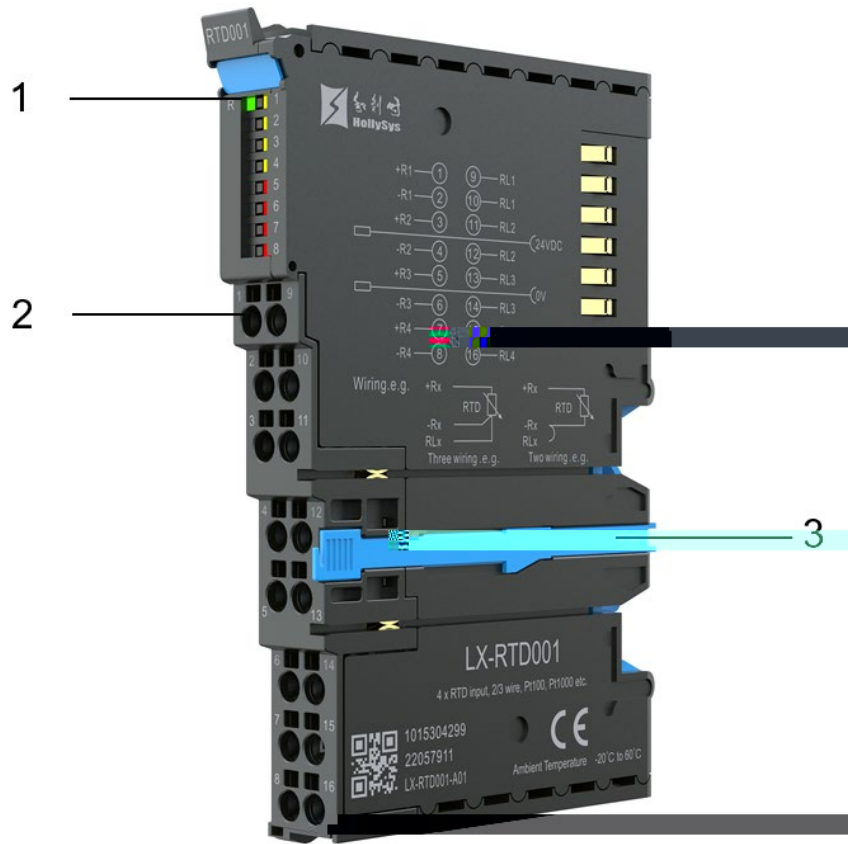

Schematic diagram of the LX-RTD001 module

Module component description table

S/N	Component Name	Instructions

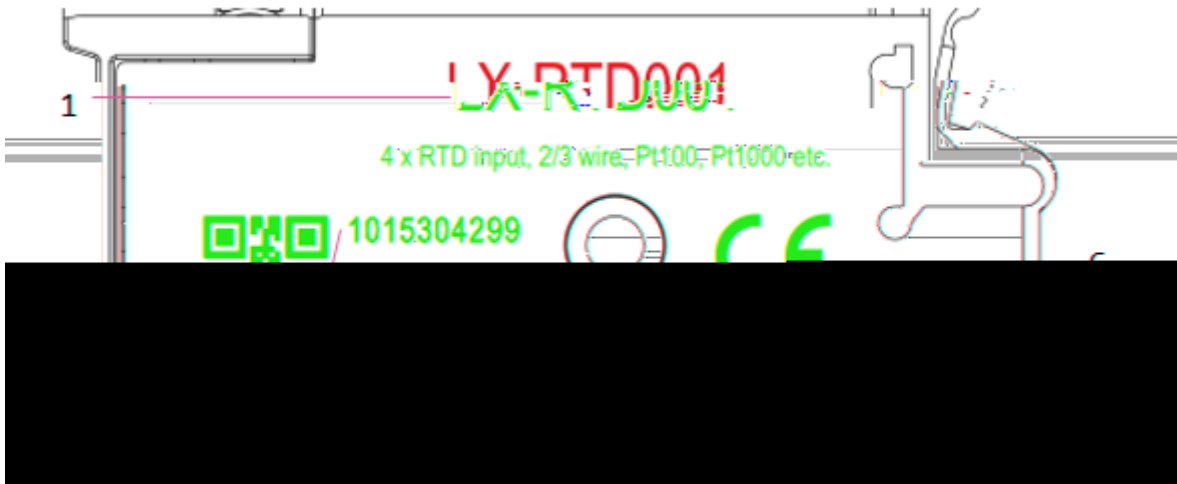

Nameplate schematic diagram

Nameplate information description table

S/N	Name	Meaning

11.7.1.2 Technical Indicators

Item	Specifications

Item	Specifications

Item	Specifications



The definition of terminals

S/N	Description of Signals	Description	S/N	Description of Signals	Description
1	+R0	Channel 1 positive	9		Channel 1 common terminal
2	-R0	Channel 1 negative	10		Channel 1 common terminal
3		Channel 2 positive	11		Channel 2 common terminal
4		Channel 2 negative	12		Channel 2 common terminal
5	+R2	Channel 3 positive	13		Channel 3 common terminal
6		Channel 3 negative	14		Channel 3 common terminal
7		Channel 4 positive	15		Channel 4 common terminal
8	-R3	Channel 4 negative	16	RL3	Channel 4 common terminal

11.7.1.5 Parameter specification

Parameter description for DeviceNet slave

Configuration Parameters	Function Description	Parameter Range	Configuration Description (Default)

11.7.1.6 Diagnostic Alarm

Description of diagnostic information

Type	Parameters	Fault Name	Diagnostic Information
			FALSE TRUE
			FALSE TRUE
			TRUE FALSE
			FALSE TRUE
			FALSE TRUE

11.8 TC Module

11.8.1 LX-TC001 4-channel Thermocouple Analog Input Module

11.8.1.1 Product Overview

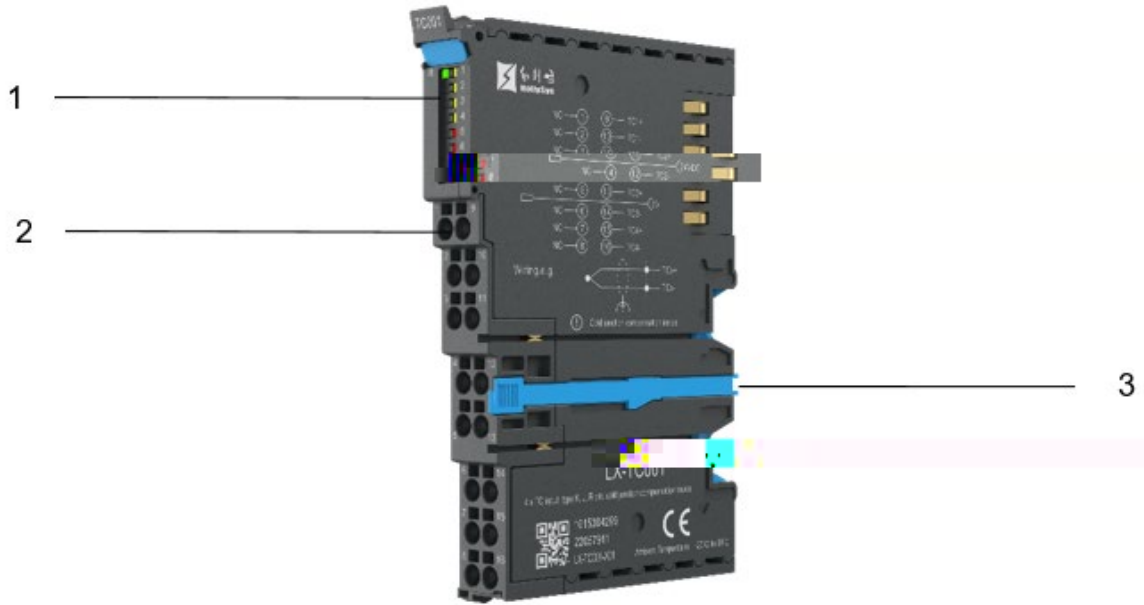

Schematic diagram of the LX-TC001 module

Module component description table

S/N	Component Name	Instructions

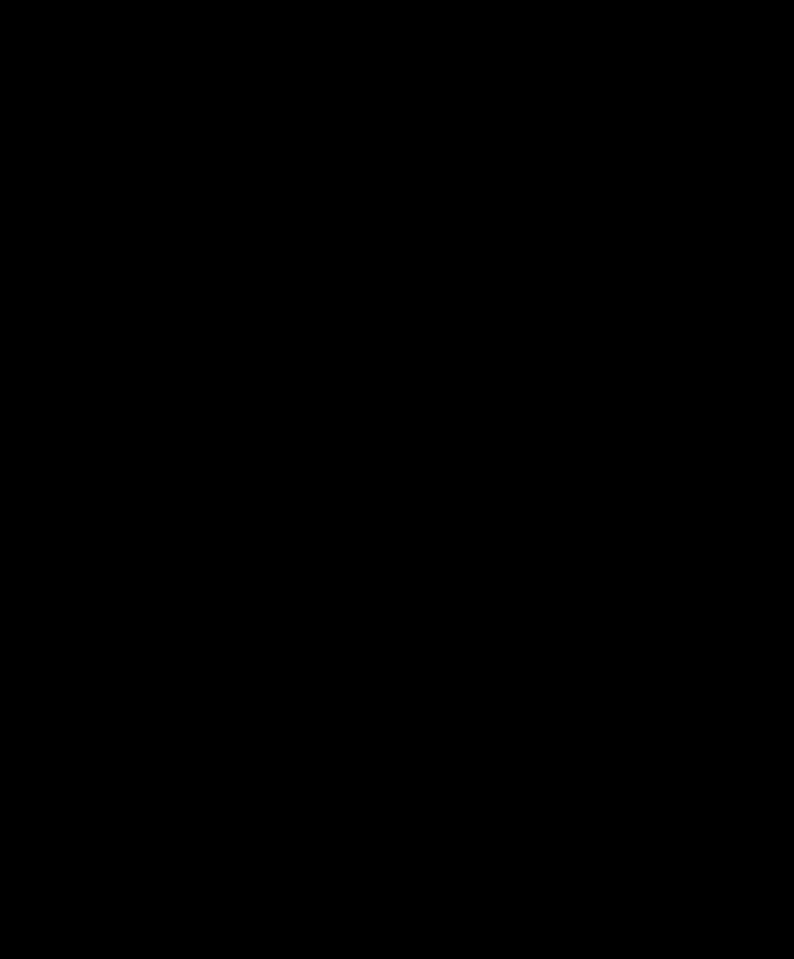

Schematic diagram

Function description table

Meaning	

11.8.1.2 Technical Indicators

Item	Specifications

11.8.1.4 Description of Terminal Components



The definition of terminals

Terminal Identification	Description of Signals	Description	Terminal Identification	Description of Signals	Description

11.8.1.5 Parameter specification

Parameter description for DeviceNet slave

Configuration Parameters	Function Description	Parameter Range	Configuration Description (Default)

EtherCAT IO mapping channel data

Channel Parameter Name	Parameter Meaning	Parameter Value

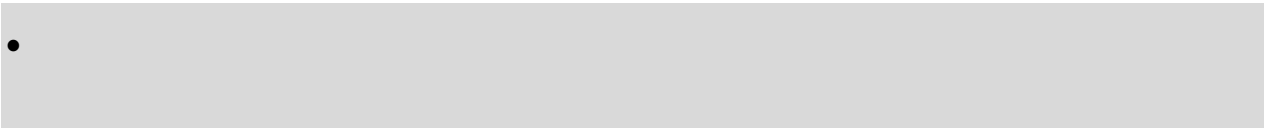

11.8.1.6 Diagnostic Alarm

Description of diagnostic information

Type	Parameters	Fault Name	Diagnostic Information
			<p style="text-align: center;">Break Wire TRUE</p> <p style="text-align: right;">EtherCATIO</p>
			<p style="text-align: center;">TRUE</p> <p style="text-align: right;">FALSE</p>
			<p style="text-align: center;">FALSE</p> <p style="text-align: right;">TRUE</p>

			OverLimit TRUE	EtherCATIO
			TRUE	FALSE
			EtherCATIO	UnderLimit TRUE

11.8.2 LX-TC601 4-channel High-precision Thermocouple Type Analog Input Module

11.8.2.1 Product Overview

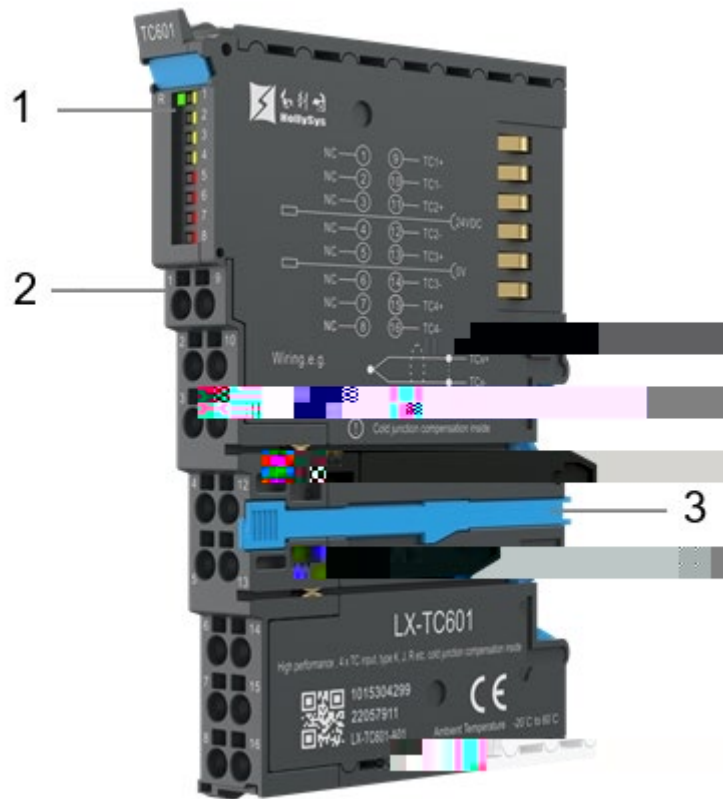

Schematic diagram of the LX-TC601 module

Module component description table

S/N	Component Name	Instructions

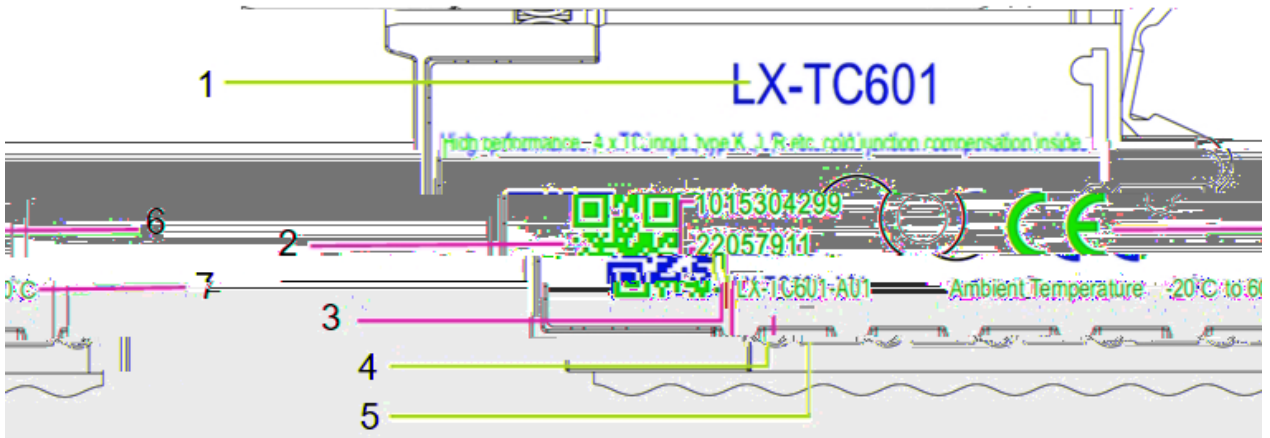

Nameplate schematic diagram

Nameplate information description table

S/N	Name	Meaning
-----	------	---------

11.8.2.4 Description of Terminal Components

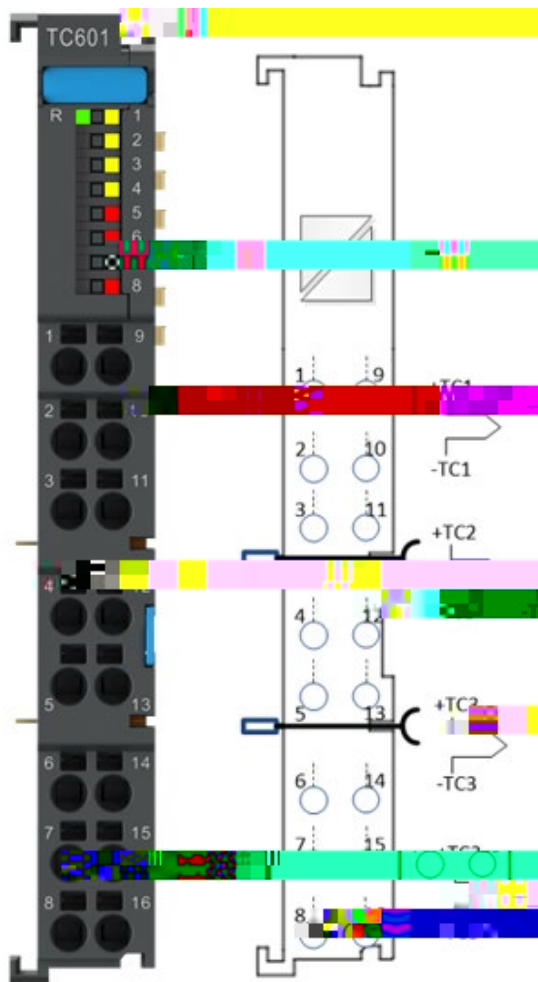

The definition of terminals

Terminal Identification	Description of Signals	Description	Terminal Identification	Description of Signals	Description

11.8.2.5 Parameter specification

Parameter description for DeviceNet slave

Configuration Parameters	Function Description	Parameter Range	Configuration Description (Default)

EtherCAT IO mapping channel data

Channel Parameter Name	Parameter Meaning	Parameter Value
------------------------	-------------------	-----------------

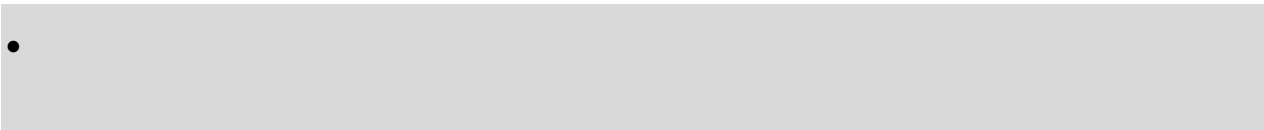

11.8.2.6 Diagnostic Alarm

Description of diagnostic information

Type	Parameters	Fault Name	Diagnostic Information
			EtherCATIO Break Wire TRUE
			TRUE FALSE
			TRUE FALSE
			TRUE

			FALSE
		OverLimit	EtherCATIO
		TRUE	
		FALSE	TRUE
		TRUE	EtherCATIO
			UnderLimit

11.9 AO Module

11.9.1 LX-AO002 8-channel Voltage Type Analog Output Module

11.9.1.1 Product Overview

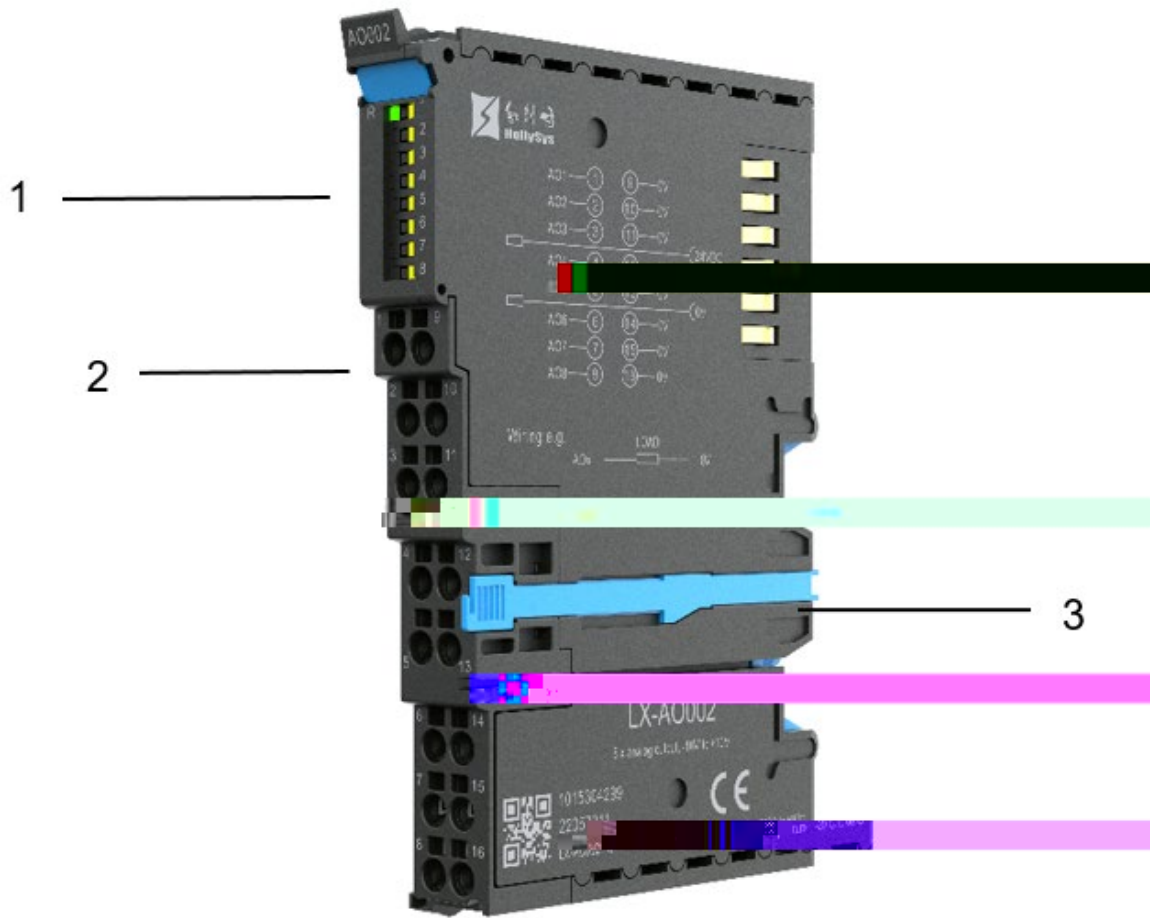

Schematic diagram of the LX-AO002 module

Module component description table

S/N	Component Name	Instructions

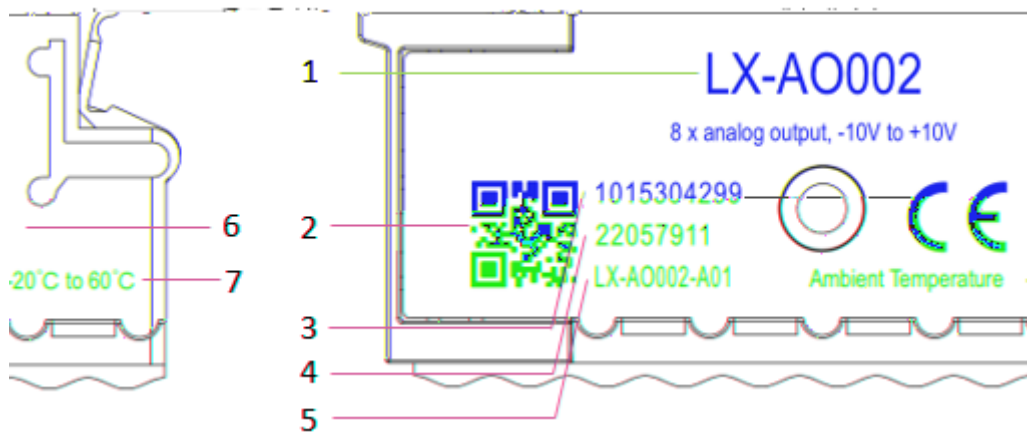

Nameplate schematic diagram

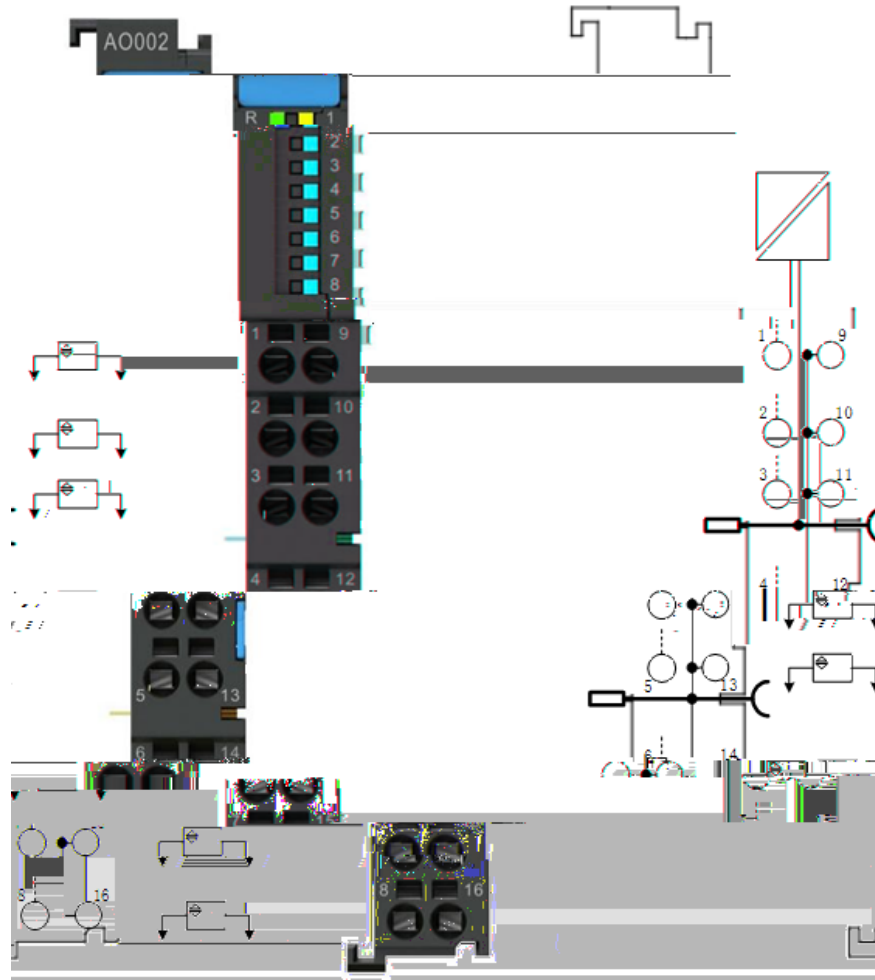

The definition of terminals

S/N	Description of Signals	Description	S/N	Description of Signals	Description

11.9.1.5 Parameter specification

Parameter description for DeviceNet slave

Configuration Parameters	Function Description	Parameter Range	Configuration Description (Default)

11.9.2 LX-AO102 8-channel high-accuracy voltage-type analog output module

11.9.2.1 Product Overview

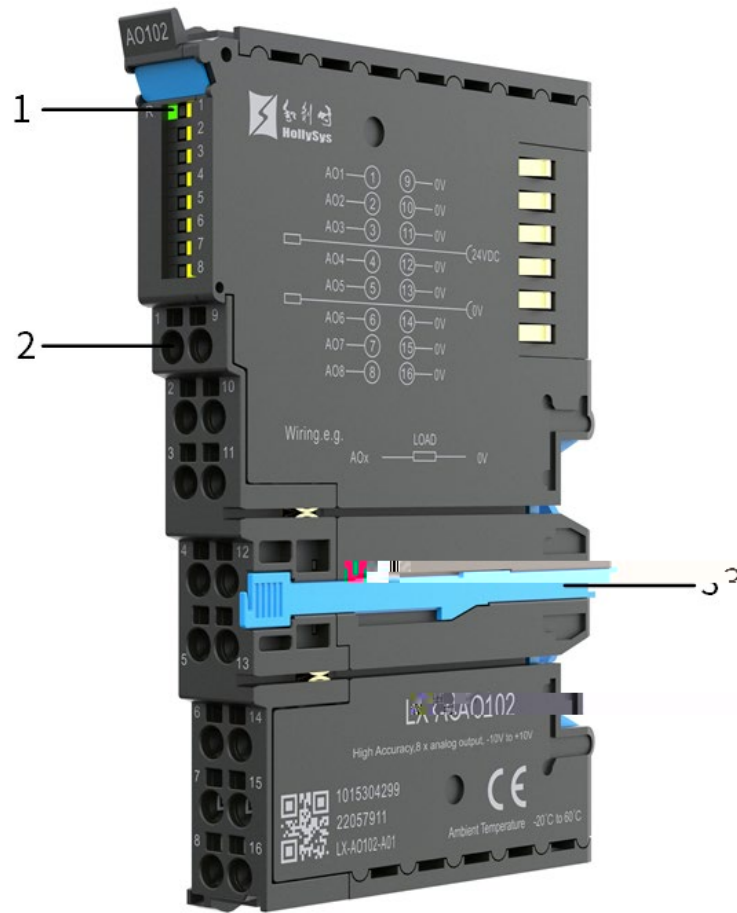

Schematic diagram of the LX-AO102 module

Module component description table

S/N	Component Name	Instructions

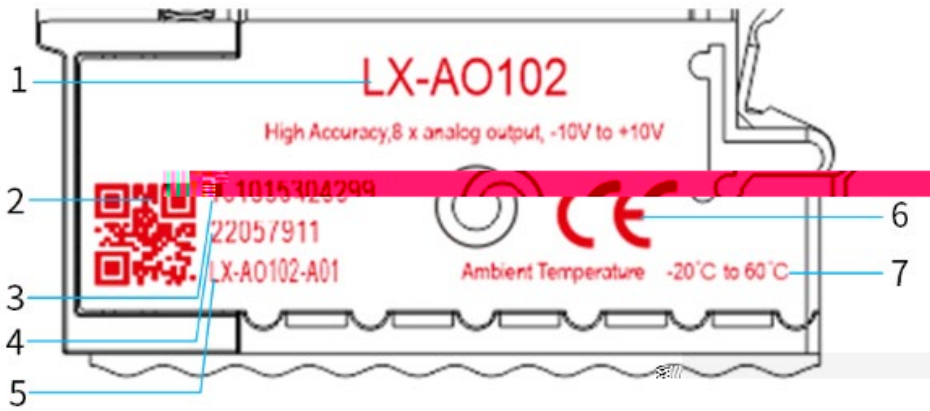

Nameplate schematic diagram

Nameplate information description table

S/N	Name	Meaning
-----	------	---------

	60us (single channel)
	>1k
	100μs

11.9.2.3 Status Indicators

Name		Color	Status Description

11.9.2.4 Description of Terminal Components

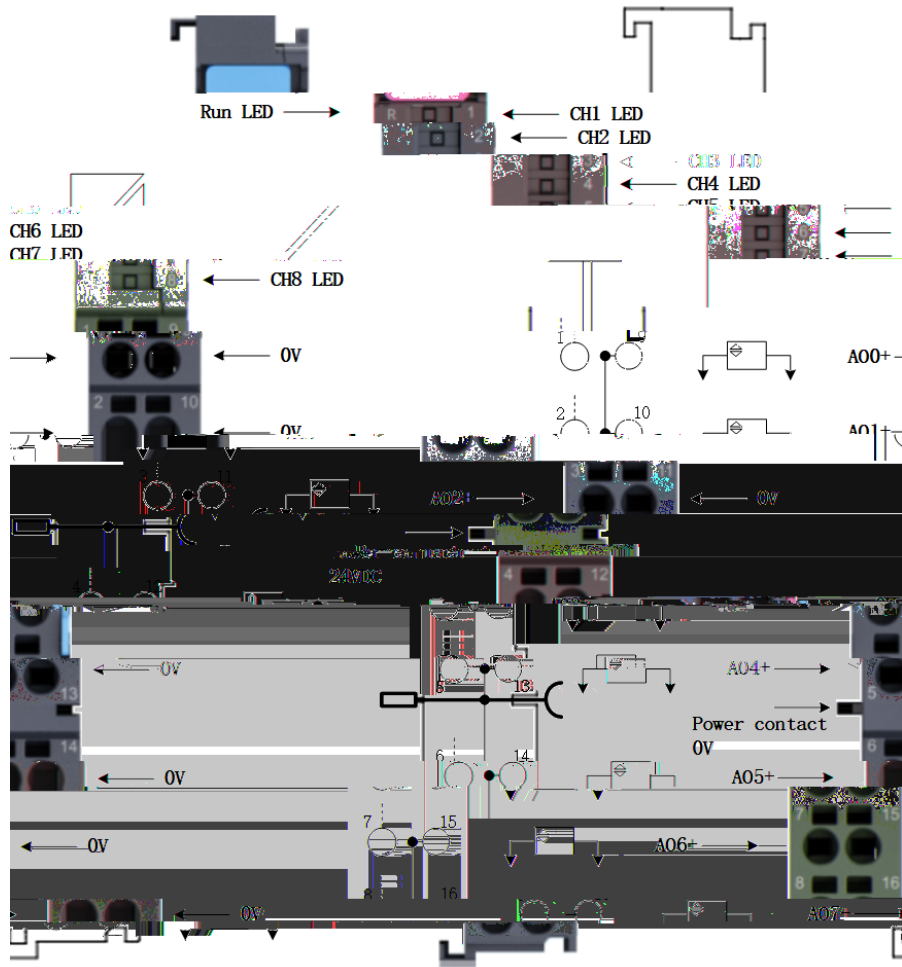

The definition of terminals

S/N	Description of Signals	Description	S/N	Description of Signals	Description



11.9.3 LX-AO003 4-channel Voltage/Current Type Analog Output Module

11.9.3.1 Product Overview

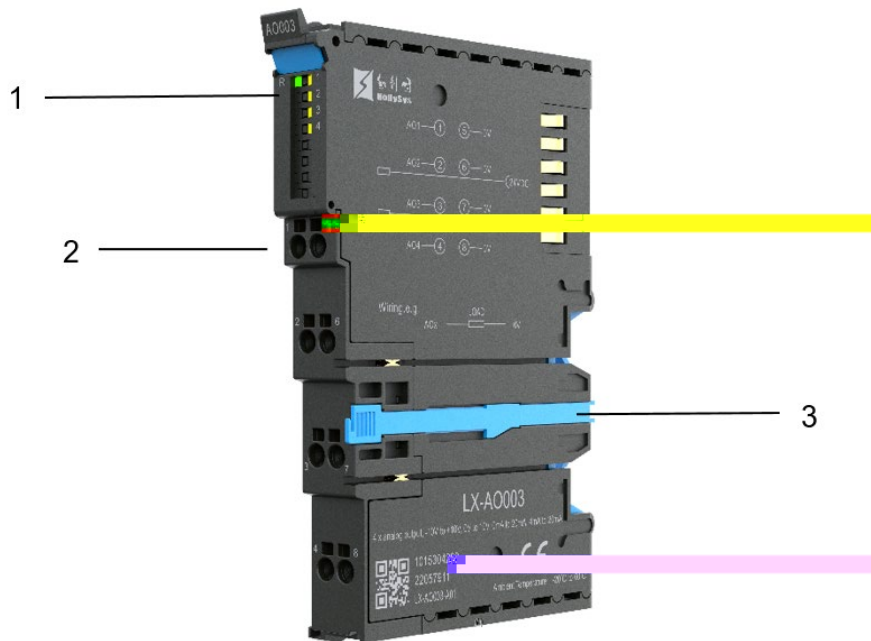

Schematic diagram of the LX-AO003 module

Module component description table

S/N	Component Name	Instructions

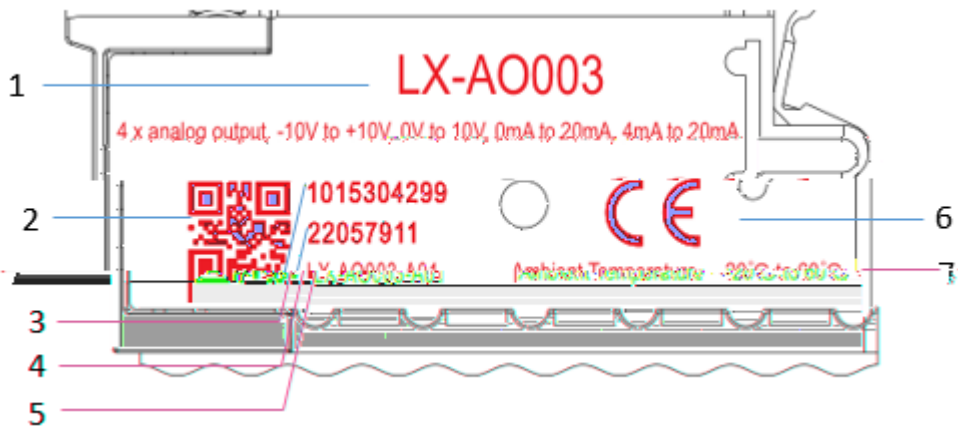

Nameplate schematic diagram

Nameplate information description table

S/N	Name	Meaning

11.9.3.2 Technical Indicators

Item	Specifications

Item	Specifications
------	----------------

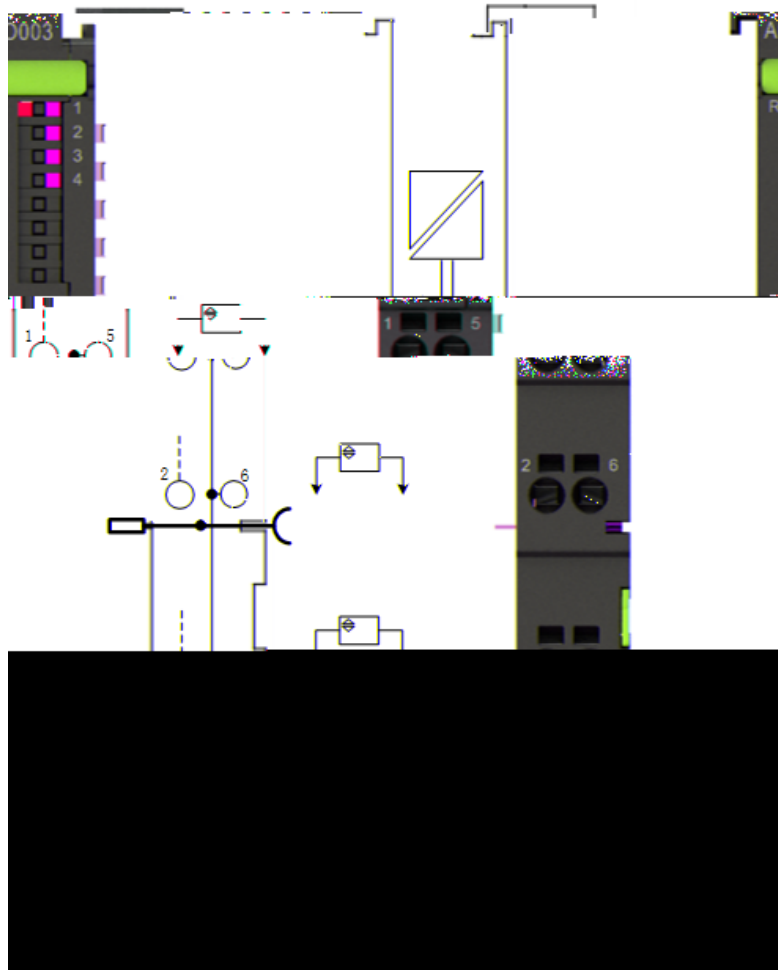

The definition of terminals

S/N	Description of Signals	Description	S/N	Description of Signals	Description

11.9.3.5 Parameter specification

Parameter description for DeviceNet slave

Configuration Parameters	Function Description	Parameter Range	Configuration Description (Default)

Chapter 12 Accessory

12.1 LX-AUX004 Module

12.1.1 Product Overview



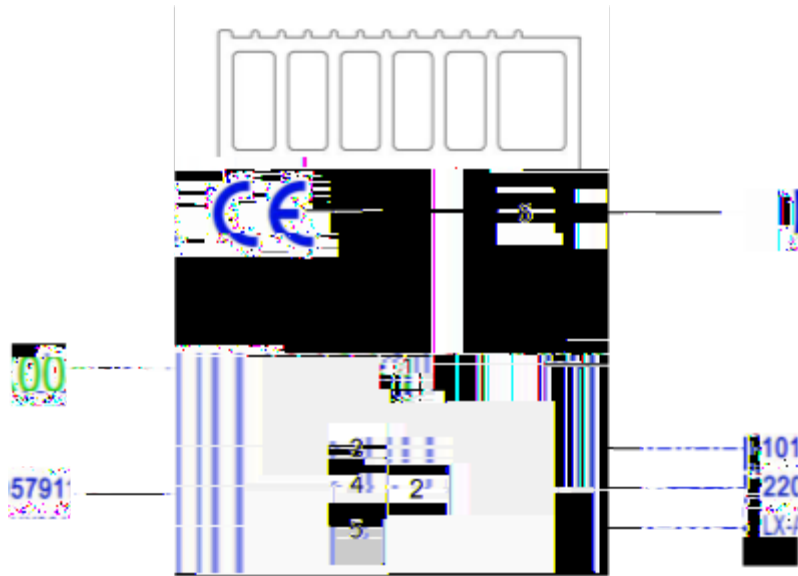

S/N	Name	Meaning

Chapter 13 Installation Guide

13.1 Installation Principles

13.1.1 Power Supply

13.1.2 Network cable routing

13.1.3 Module Installation

13.1.4 Guide rail selection and matching

13.1.5 Module Configuration

13.1.6 Selection of the number of system modules

13.2 Installation Environment

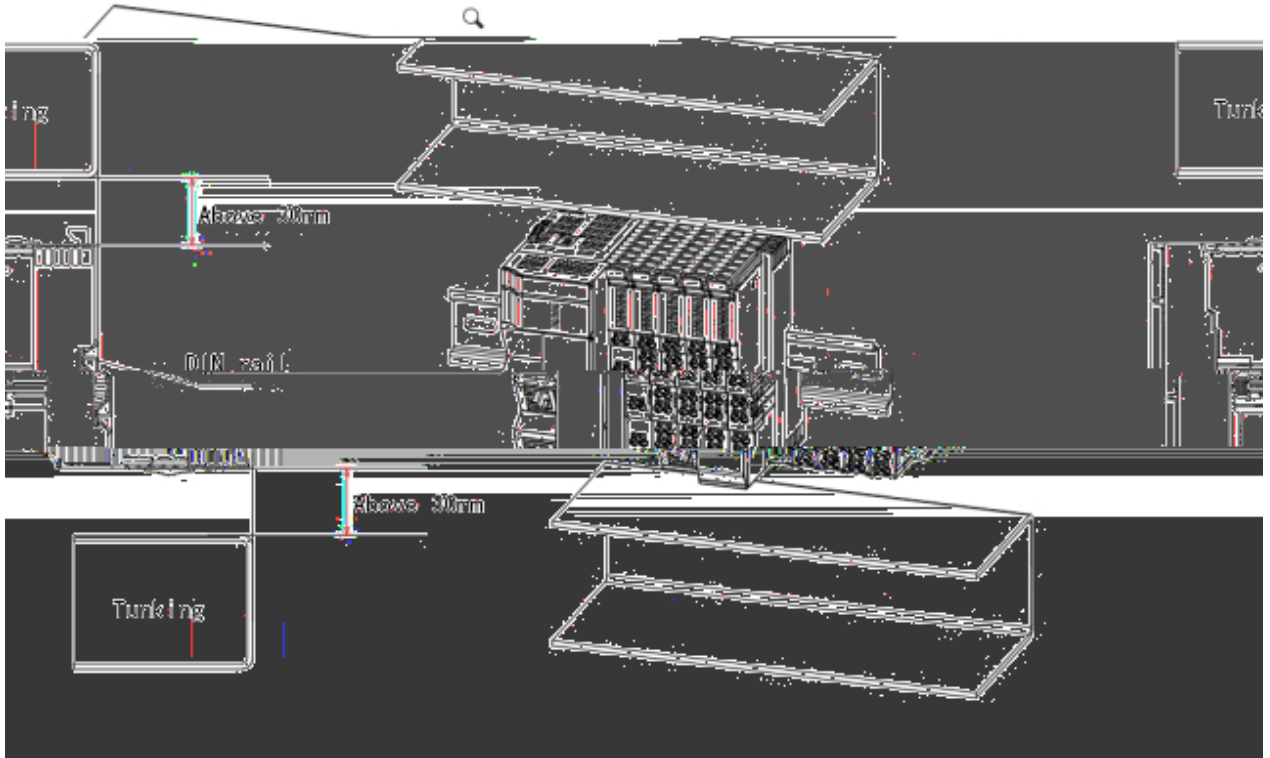

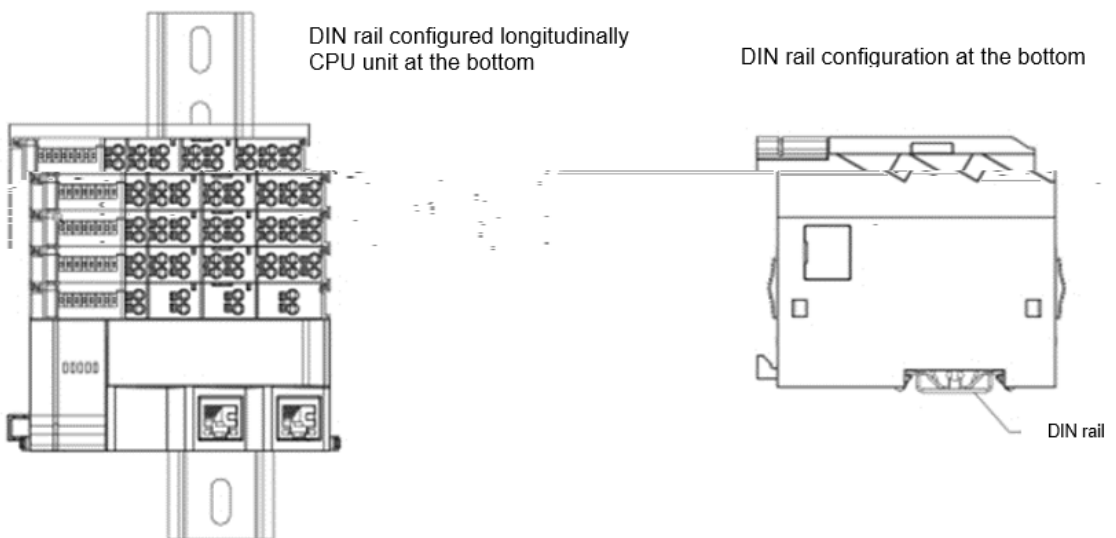
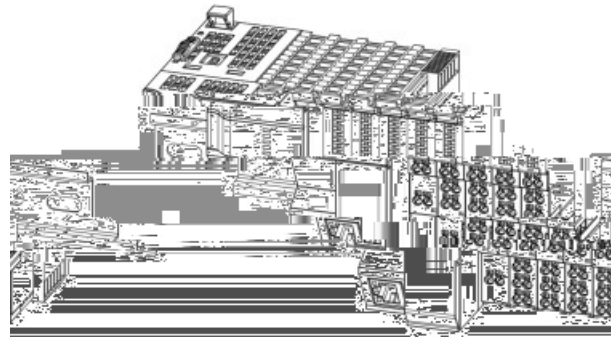
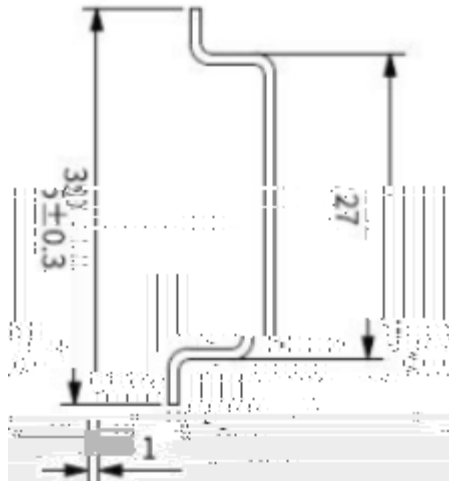

13.3 Installation Dimensions

13.3.1 Controller



13.3.2 Serial Port Module

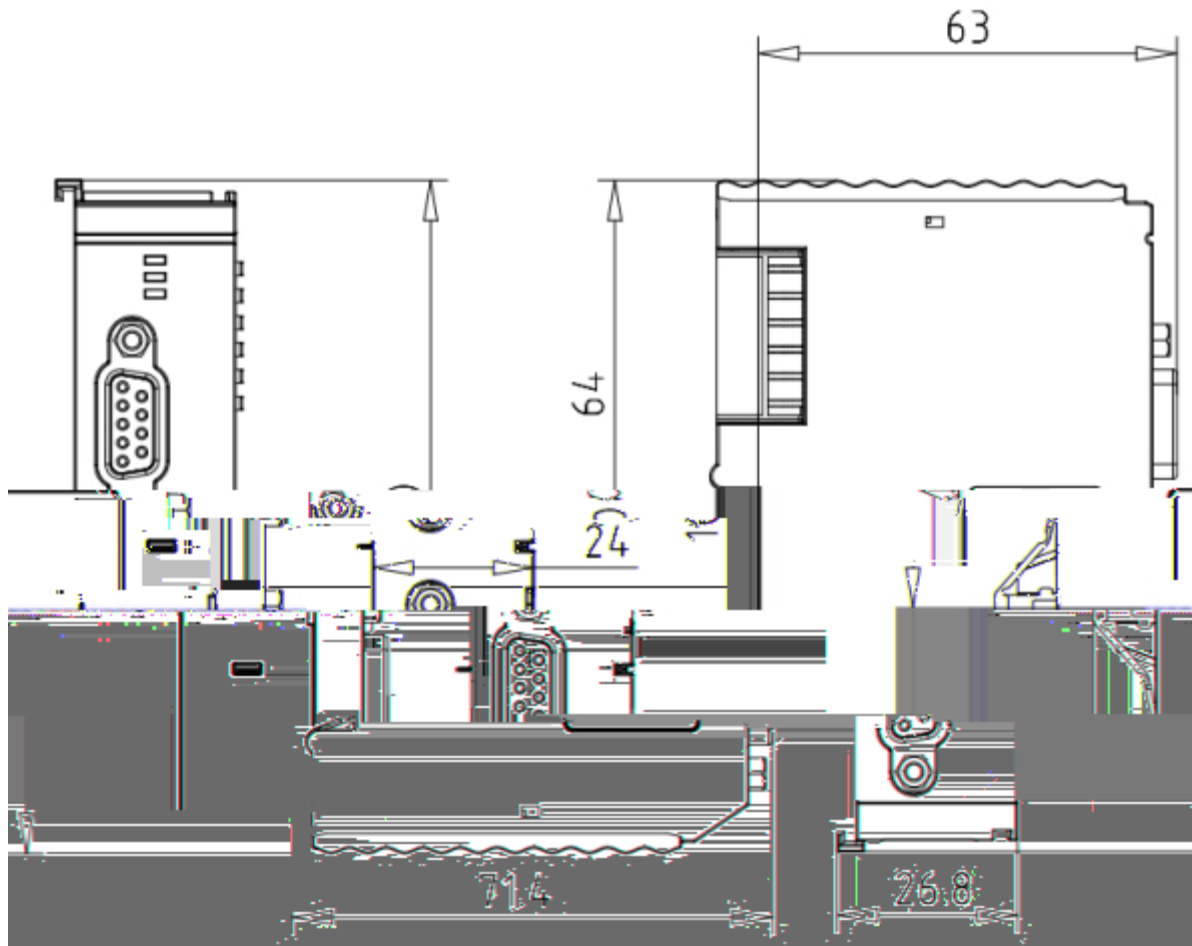

13.3.3 Power Module

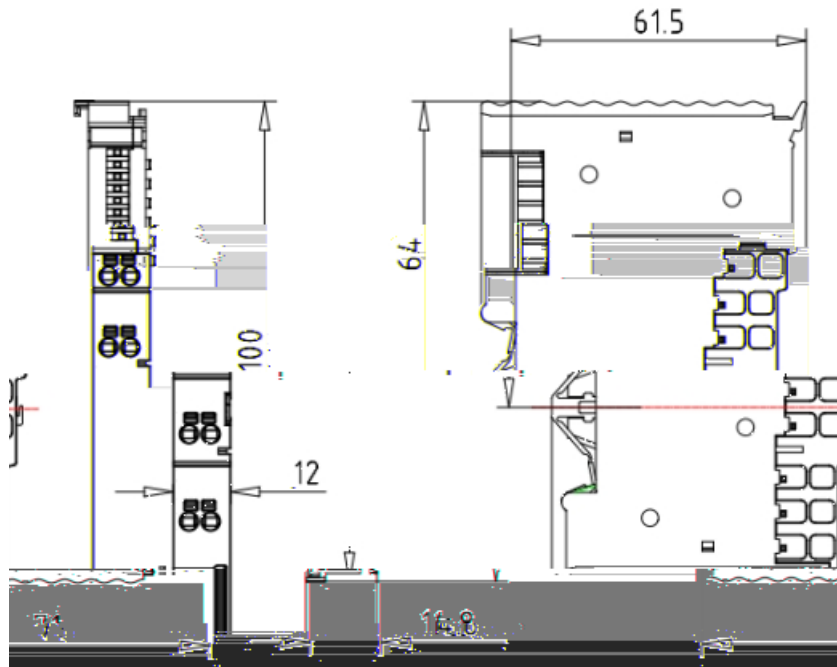

13.3.4 Communication Module

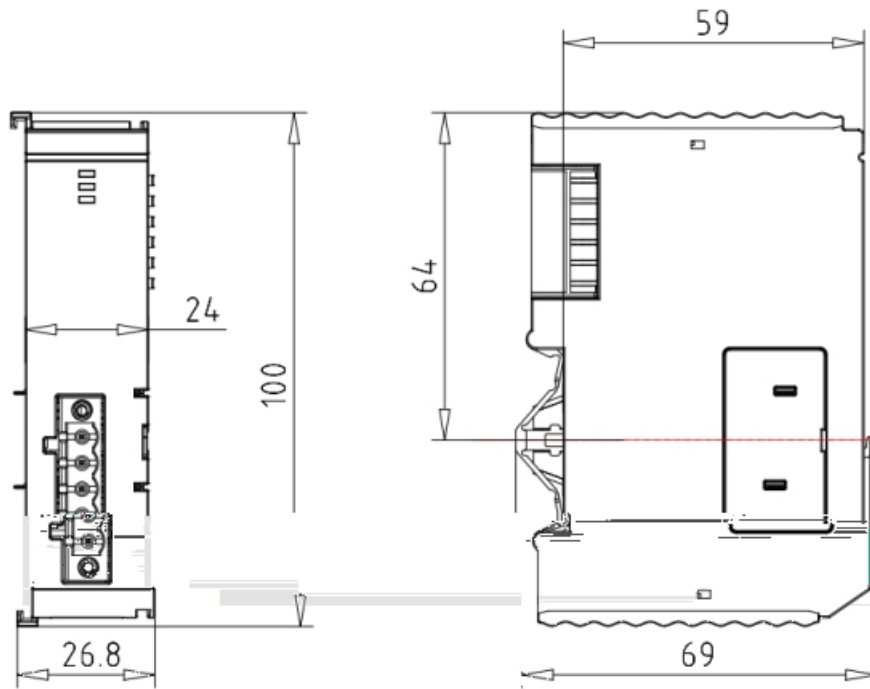

13.3.5 Coupler Module

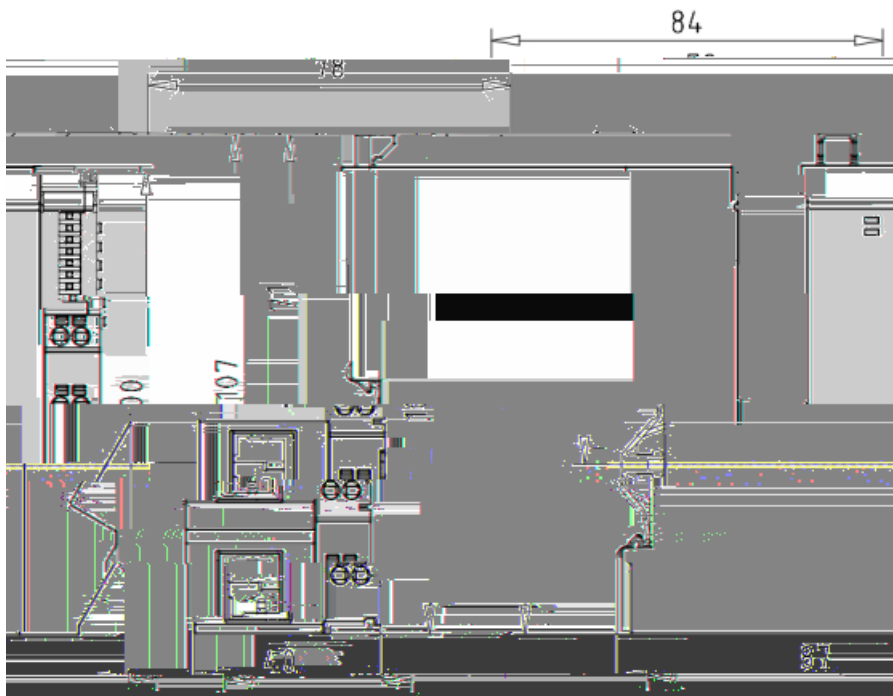



13.3.6 IO Module

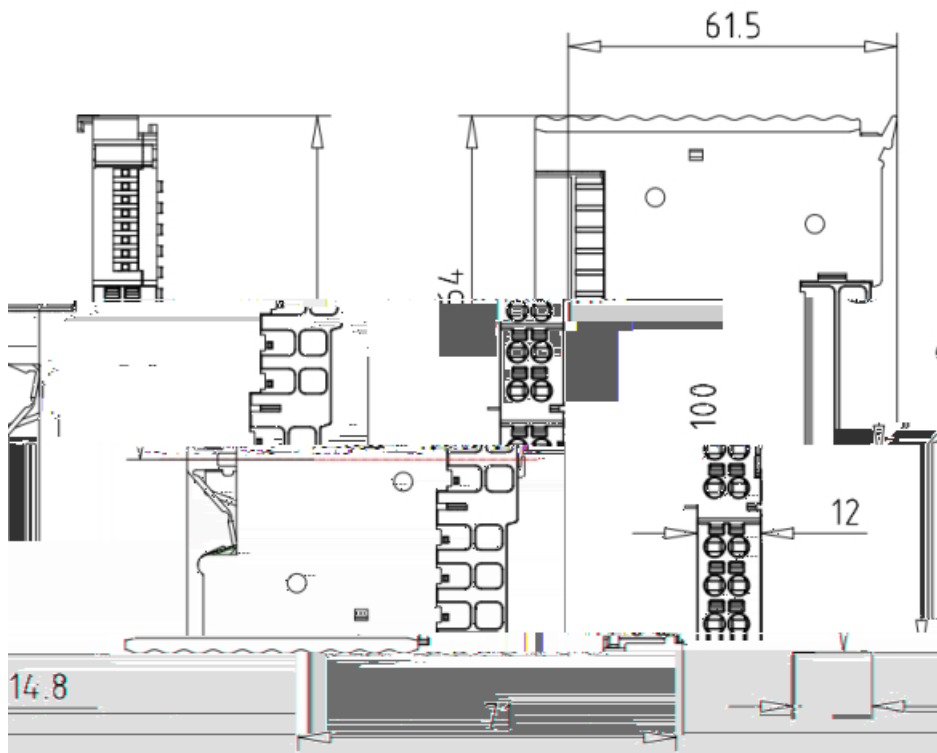
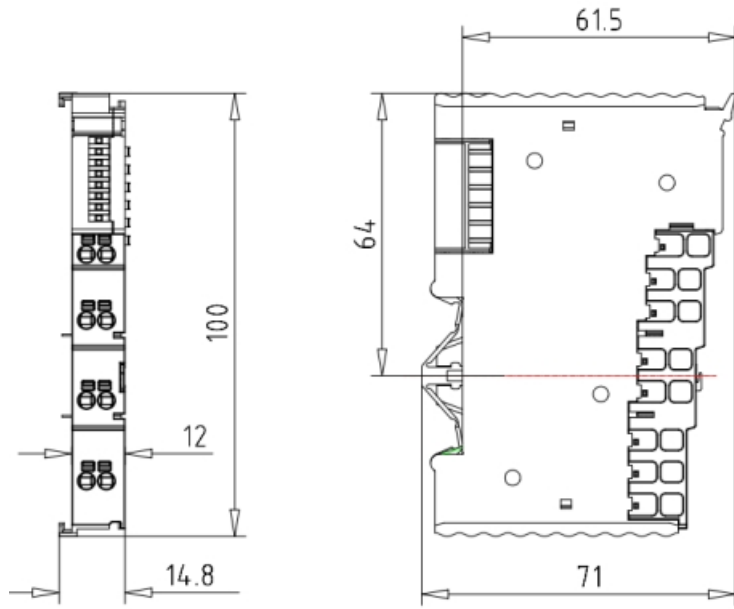

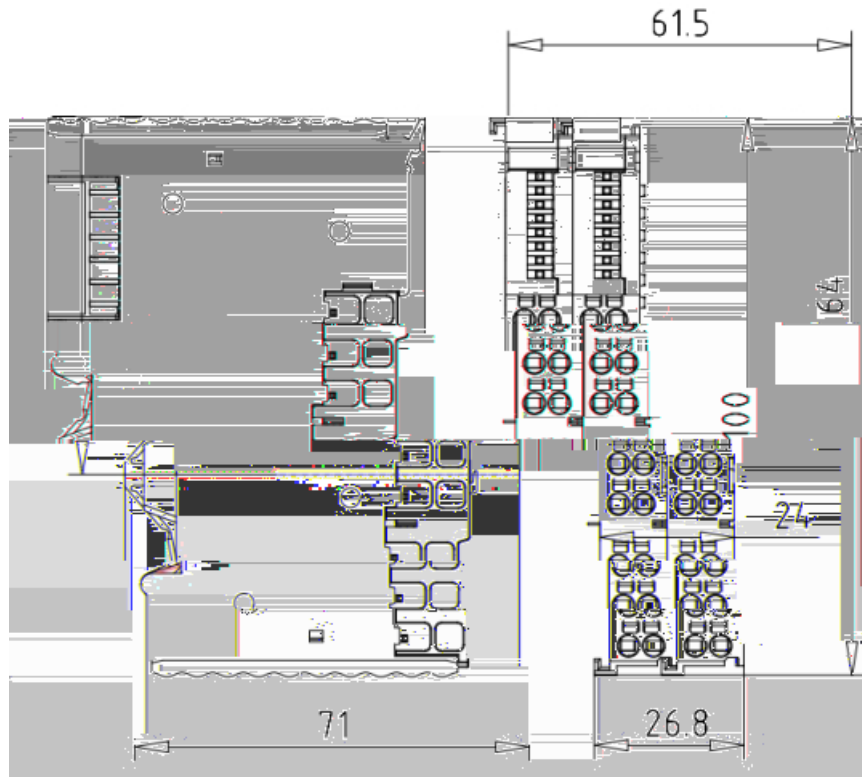

13.3.7 HUB Module

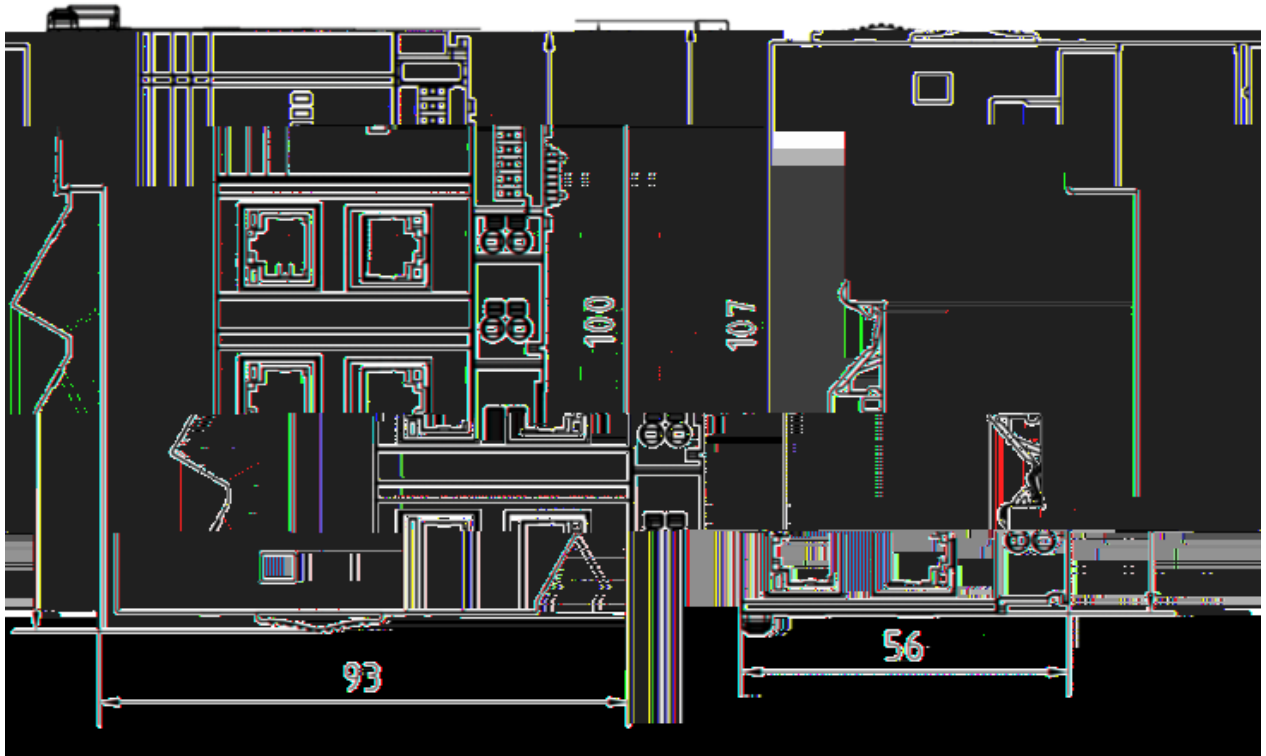

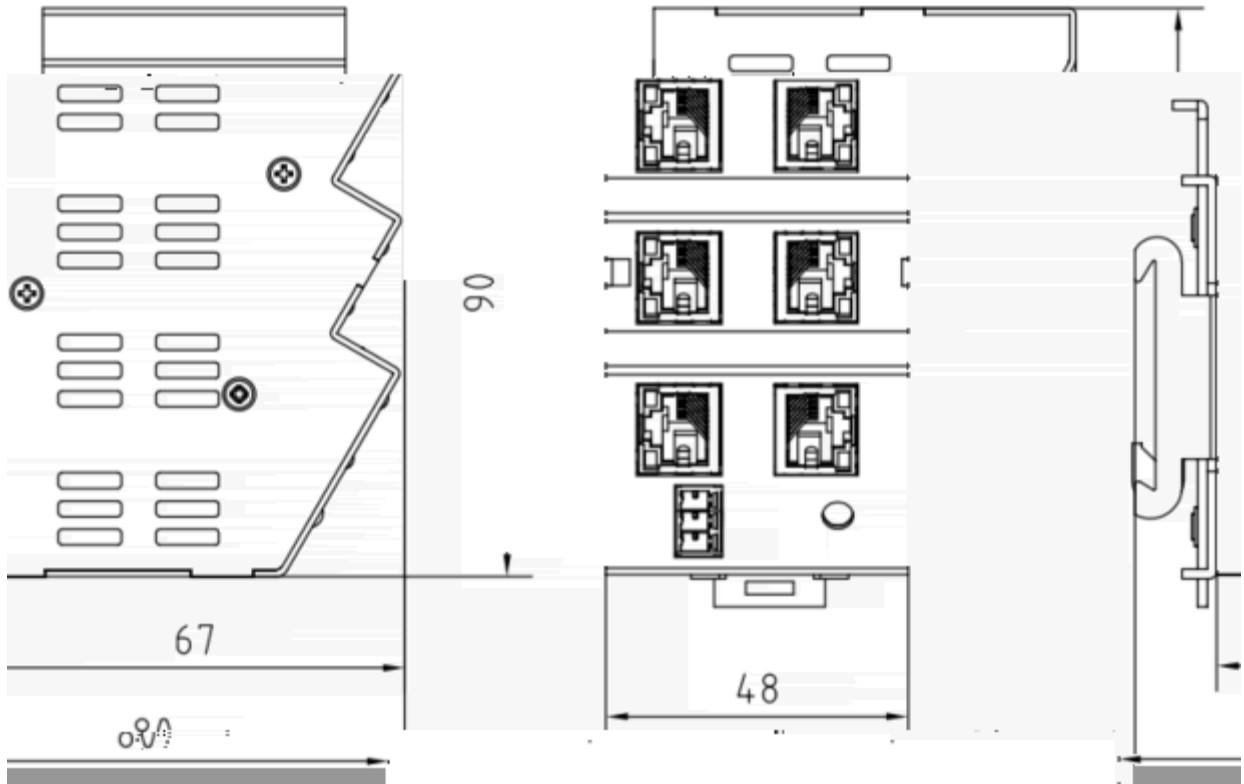

13.3.8 End cover module

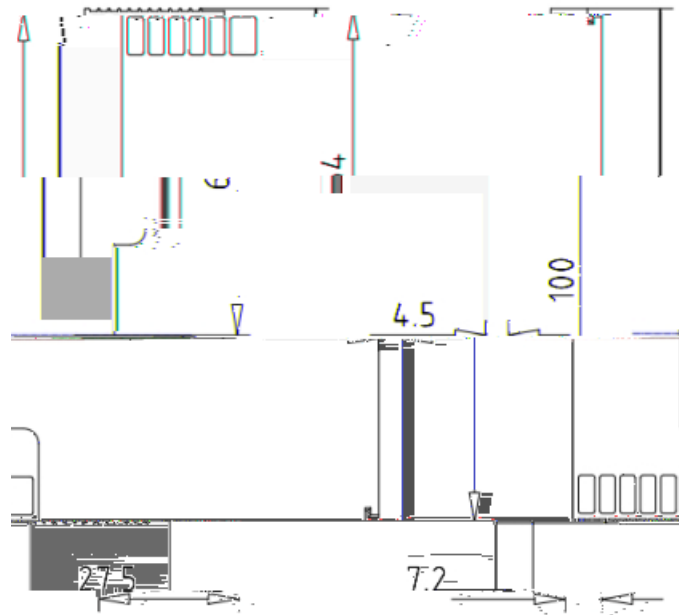

13.4 Installation and Removal

13.4.1 CPU Module Installation

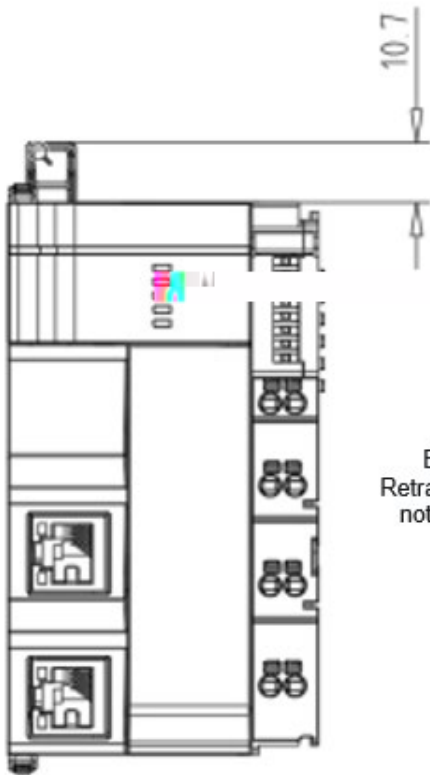
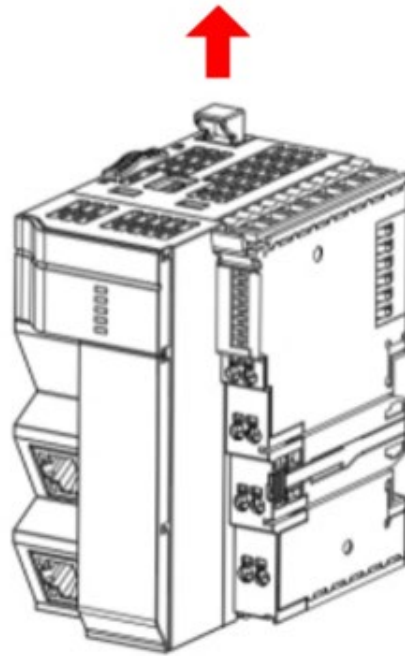

Blue hook
Retracted and
not exposed

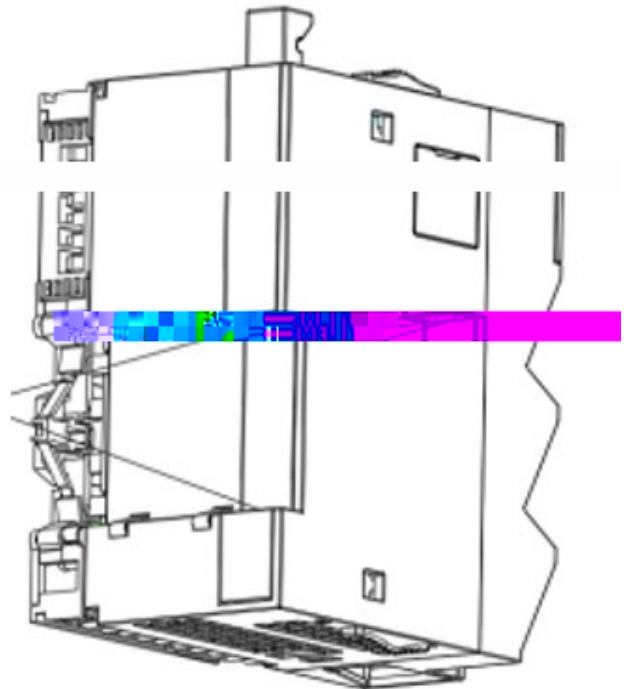

Set the unlock status

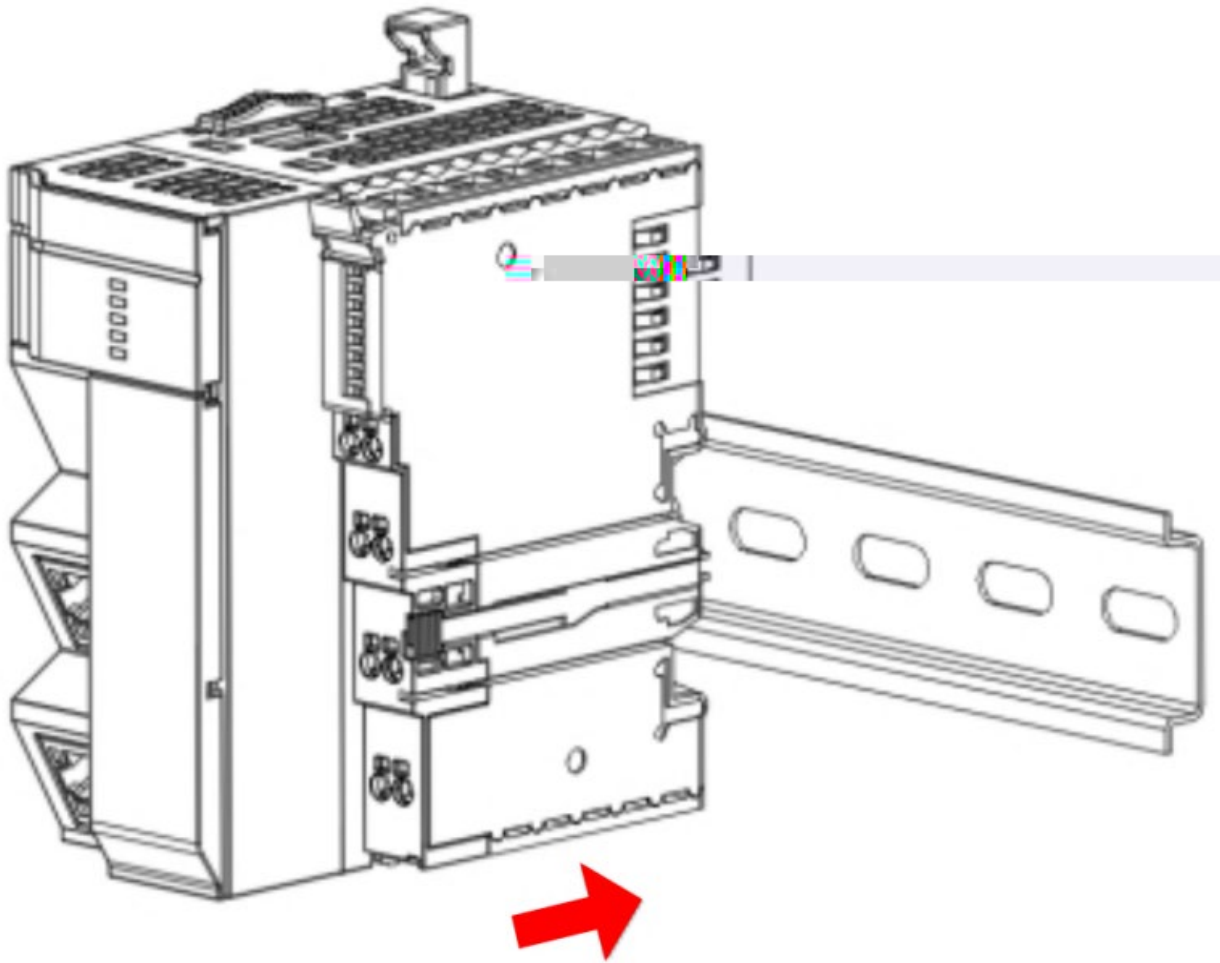

Lock the right mounting hook

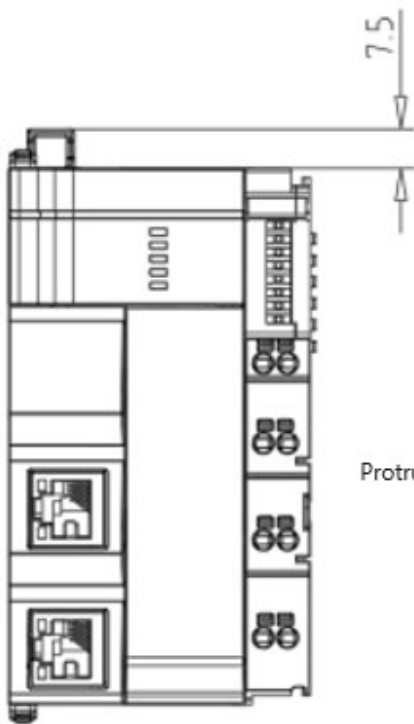
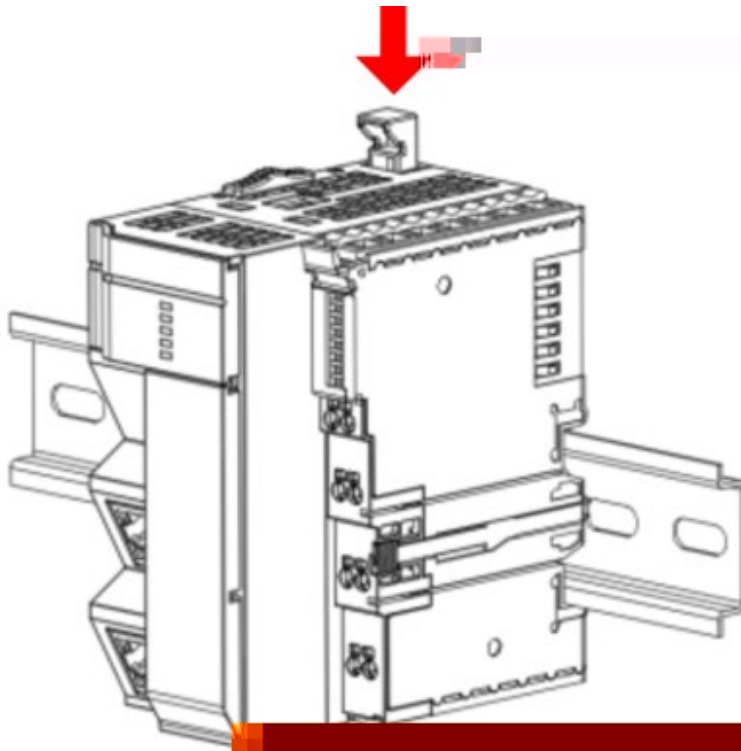

Blue hook
Protruding outward

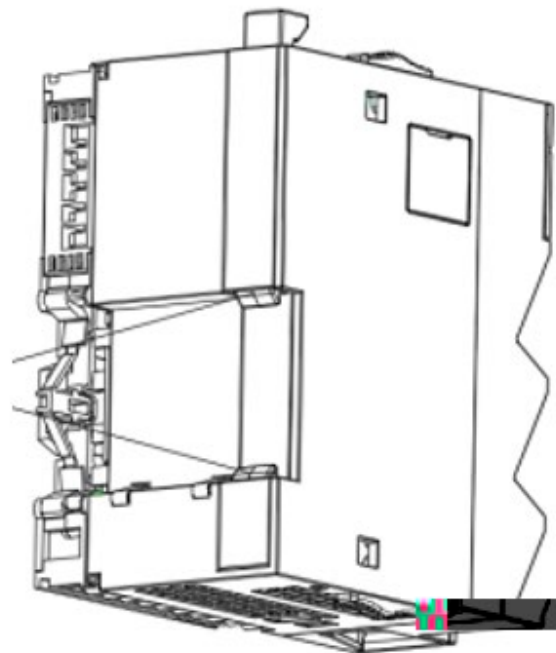

Lock the left mounting hook

13.4.2 Installation between modules

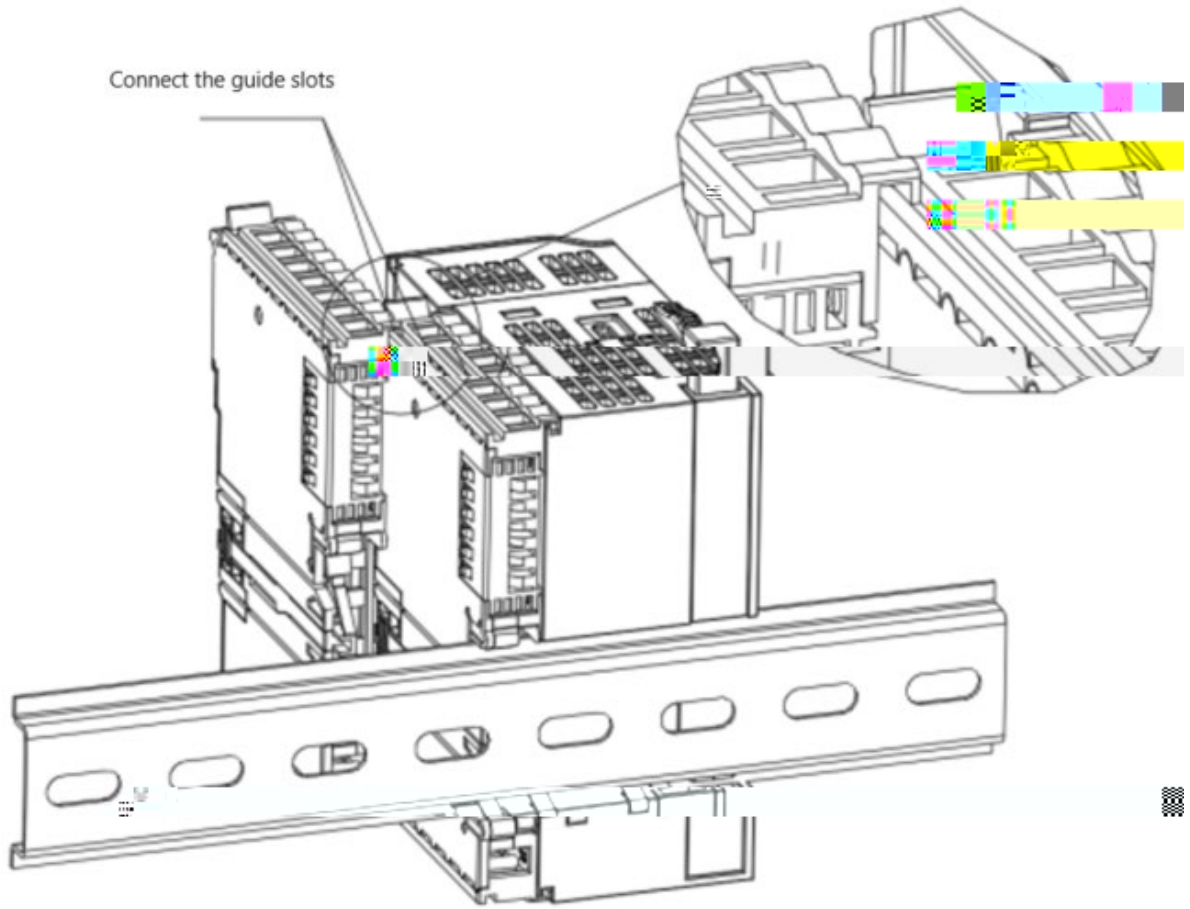

Connect the guide slots to fit together

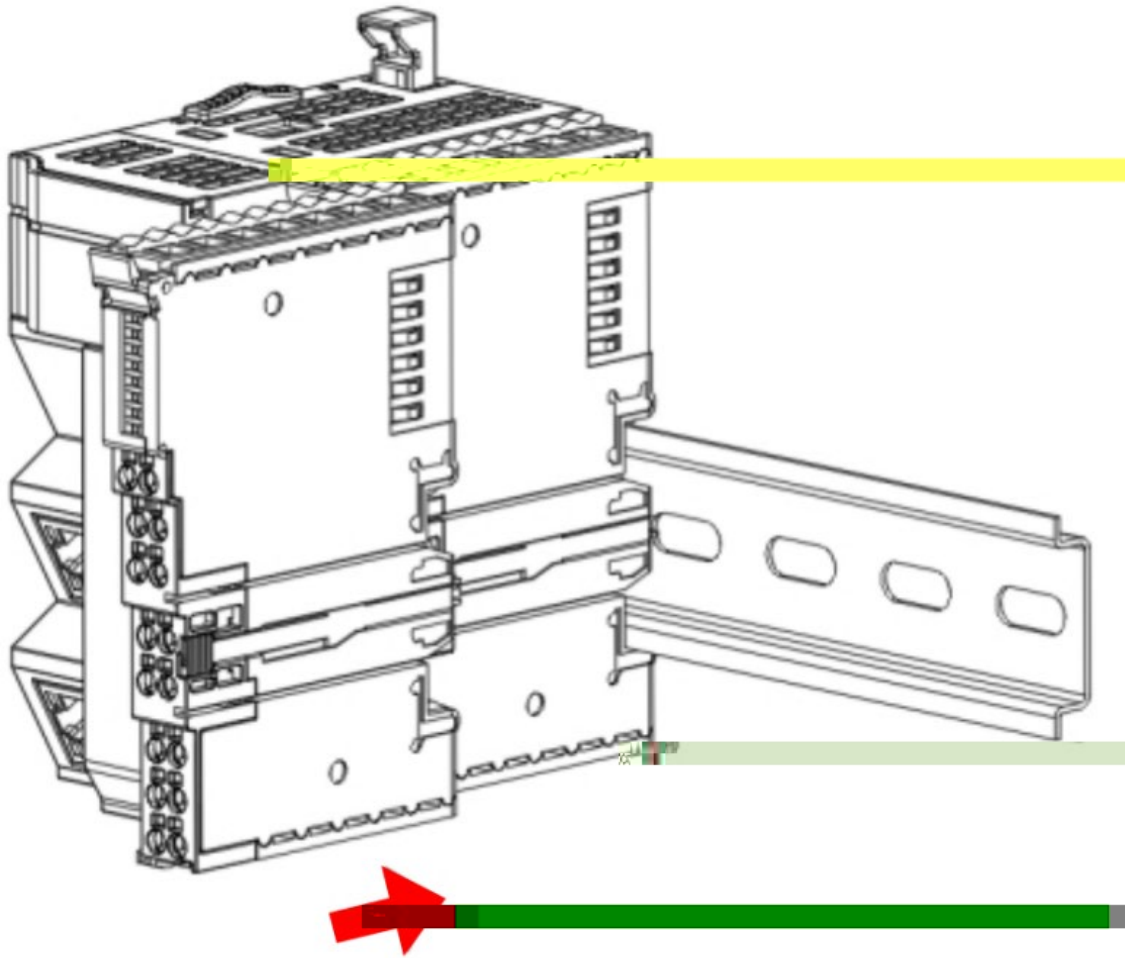

Install the module onto the rail

13.4.3 Installation of the LX-HUB107 Module

Method 1:

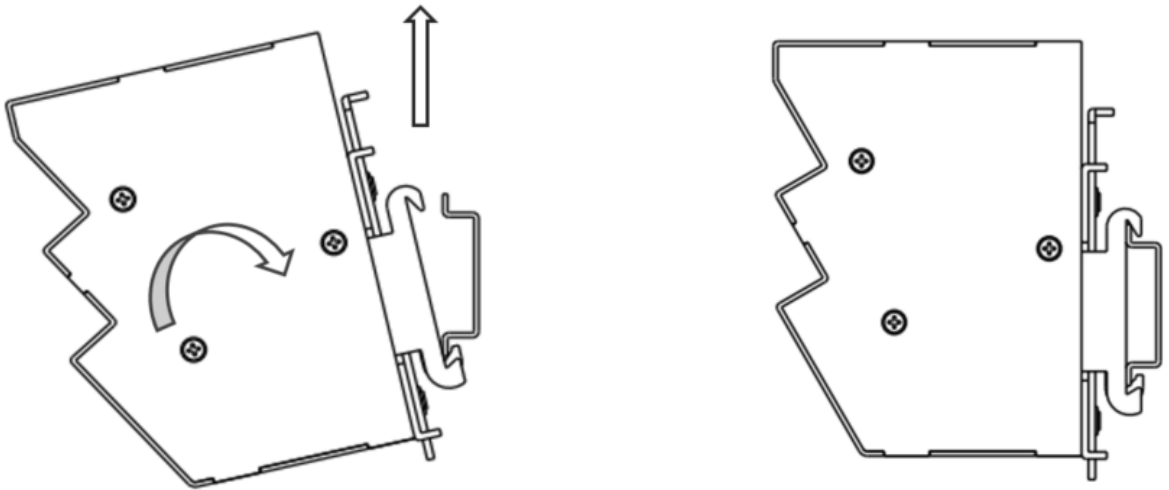

Schematic diagram of LX-HUB107 installation method 1

Method 2:



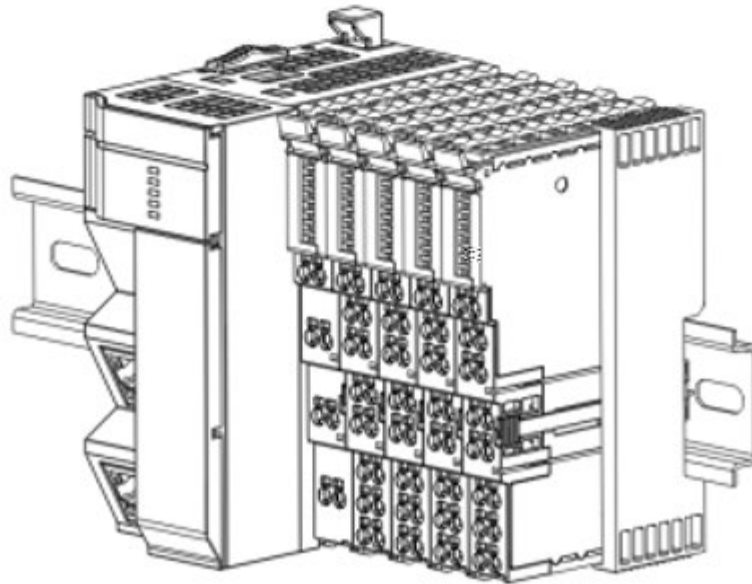
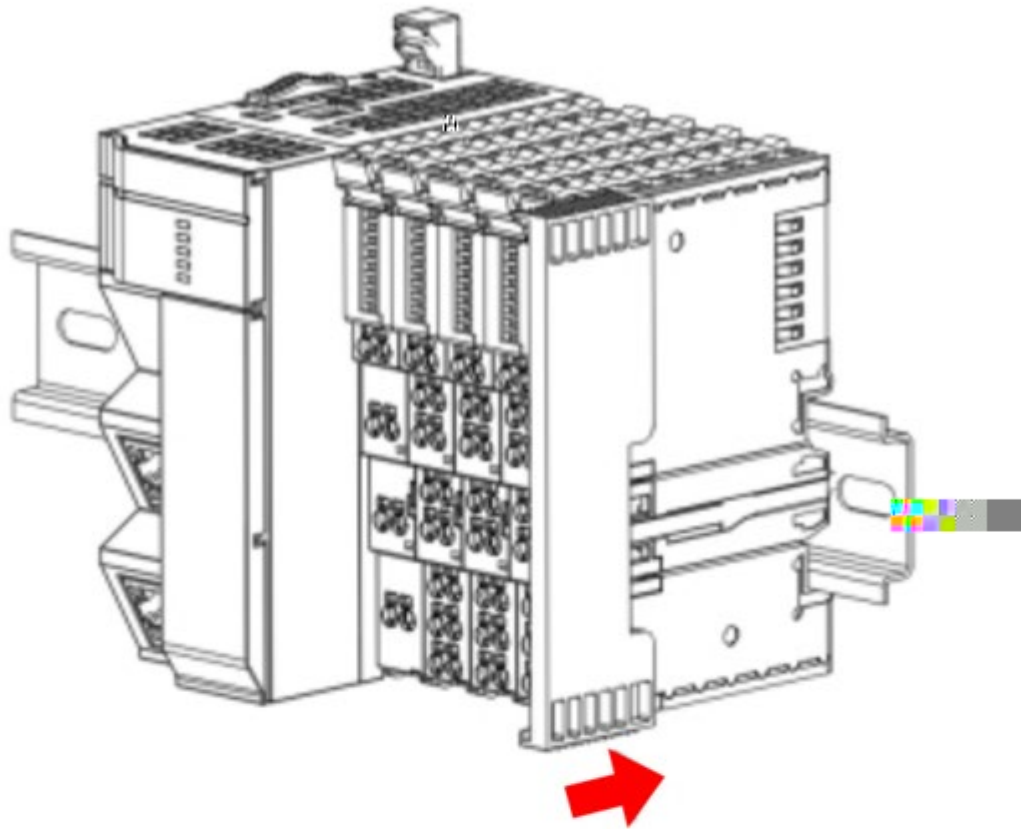

Install the end cover on the guide rail

13.4.5 Installation of End Fixtures

Installation diagram



Beijing HollySys Intelligent Technologies Co., Ltd.