

LX系列 紧凑型小型PLC

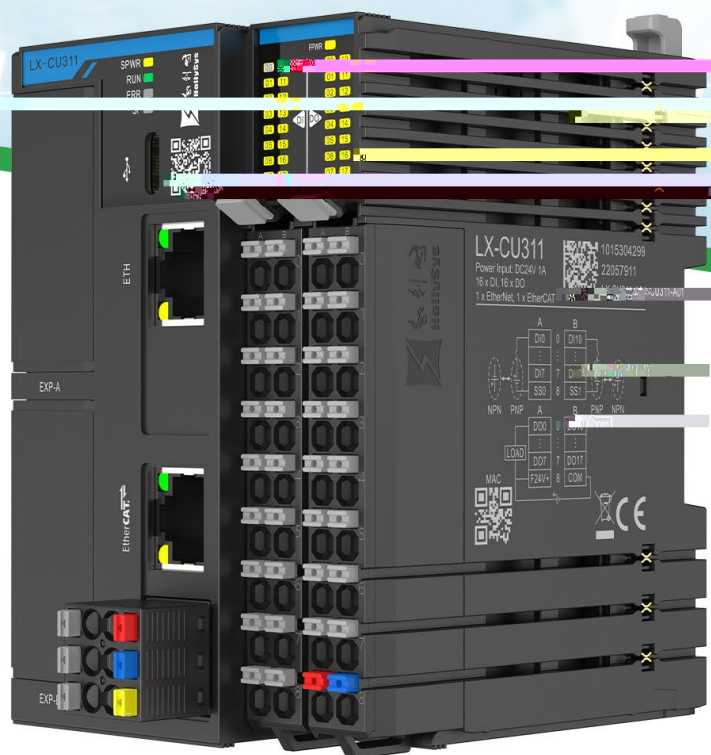



模块手册





1	1
2	3
3	/	4
4	5
5	PLC	6
6	10
7	71
8	82
9	85

10	87
11	98
12	100
13	102

2

_____ □ _____

3 /

	V5.0.0

4

W×H×D mm

5.1

5.2

5.3

--	--	--

6

6.1

6.2

6.2.1 LX-CU311 CPU

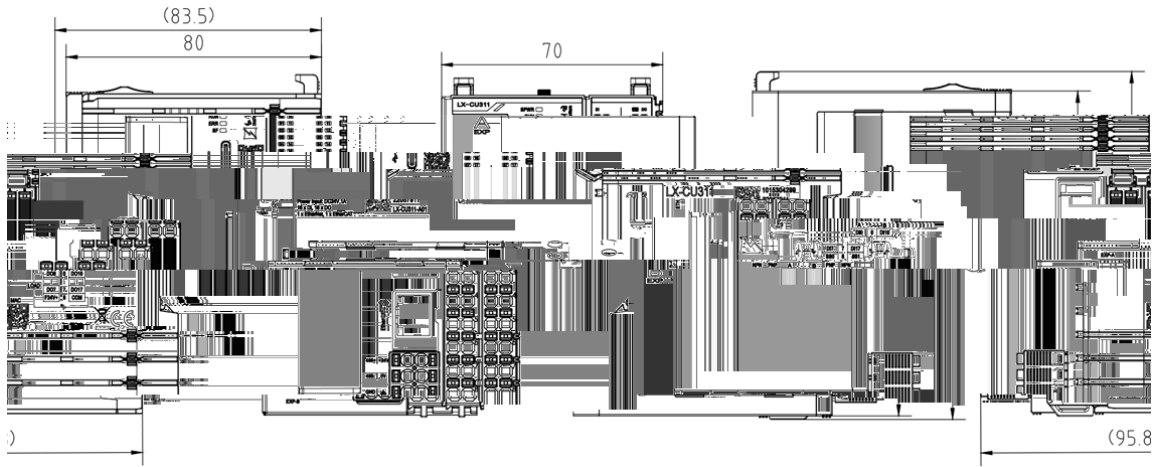

LED			
-----	--	--	--

6.2.1.2

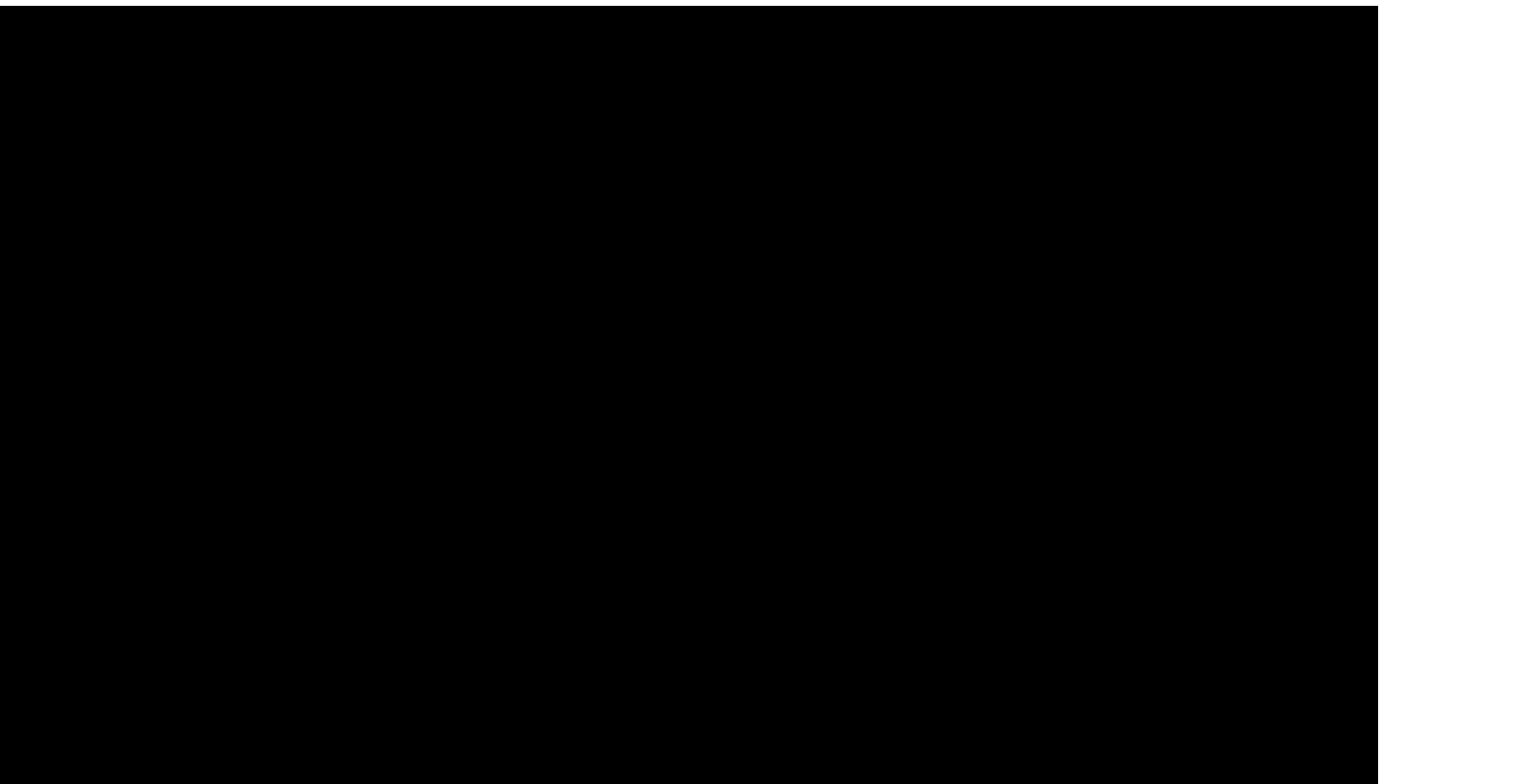

	<table border="1"> <tr> <td>通道使能</td> <td>使能</td> <td>▼</td> </tr> <tr> <td>停止后输出状态</td> <td>输出预设值</td> <td>▼</td> </tr> <tr> <td>预设值</td> <td>TRUE</td> <td>▼</td> </tr> </table> 	通道使能	使能	▼	停止后输出状态	输出预设值	▼	预设值	TRUE	▼
通道使能	使能	▼								
停止后输出状态	输出预设值	▼								
预设值	TRUE	▼								

6.2.1.4

EtherCAT

USB

E0 □

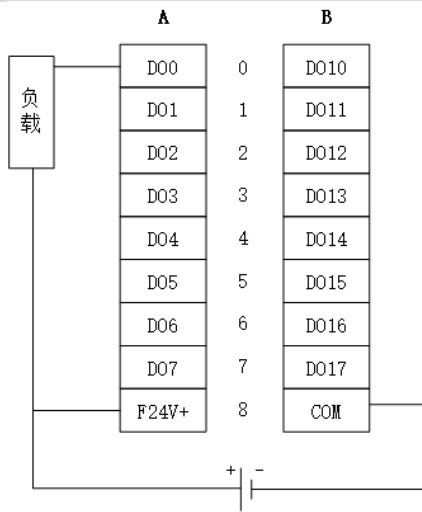
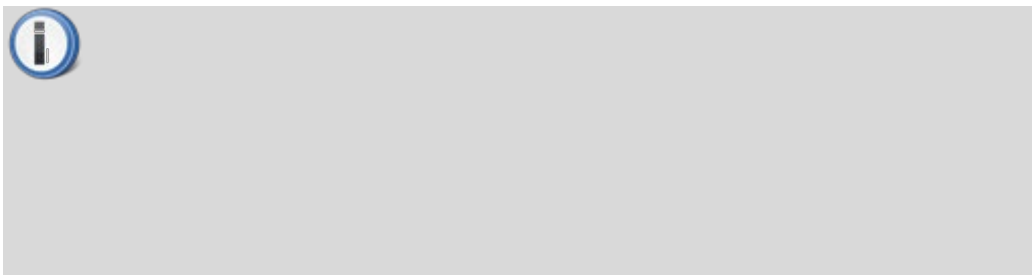

常规输出接线

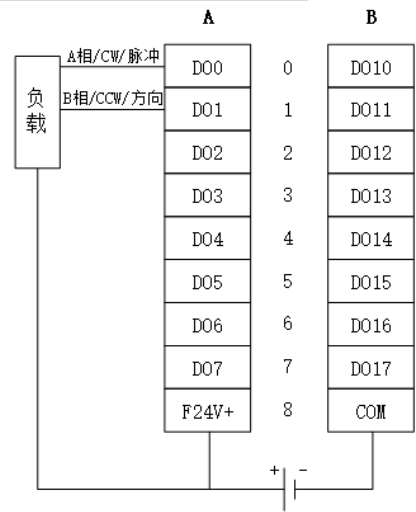

高速输出接线

6.2.1.5

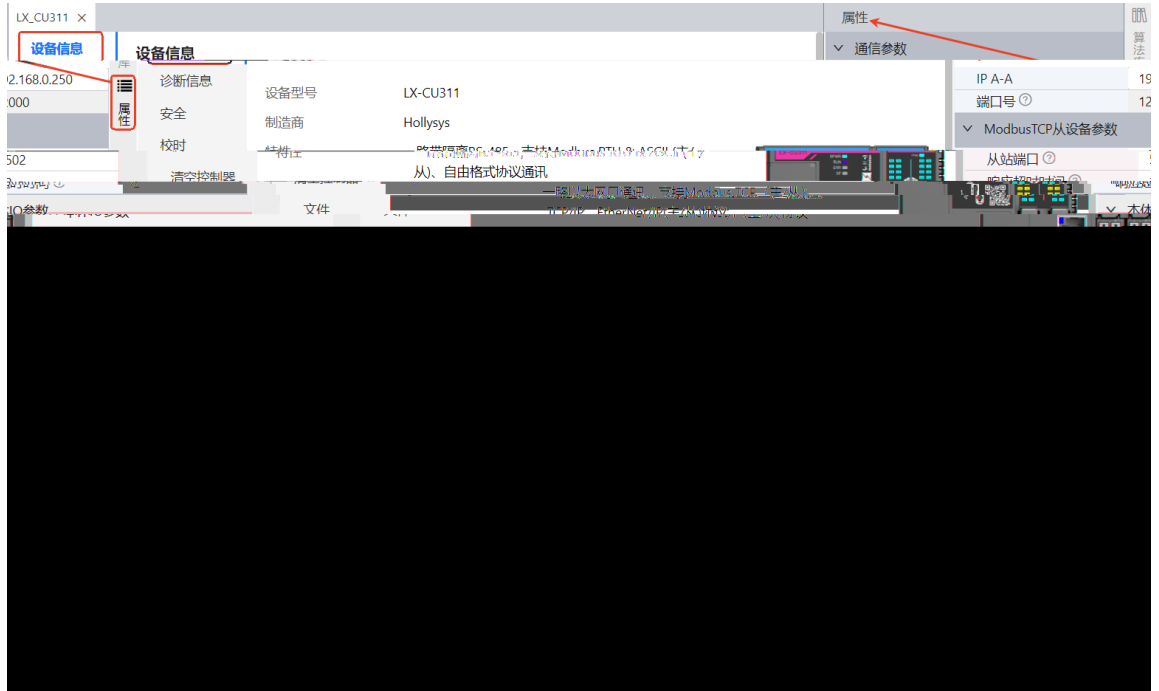

ModbusTCP		
IO		

LX_CU311 X

- 设备信息
- 诊断信息
- 安全**
- 校时
- 清空控制器
- 文件
- 固件升级
- IO映射

控制器加密

* 密码 * 确认密码

输入密码 ×

密码

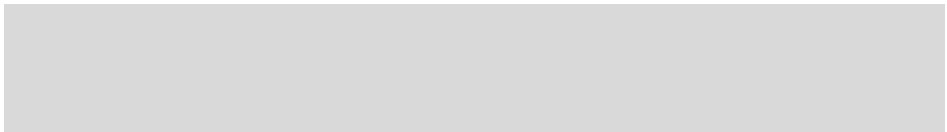

控制器校时

启用

校时周期

校时服务IP A.A

校时服务IP A.B

校时服务IP B.A

校时服务IP B.B

设置

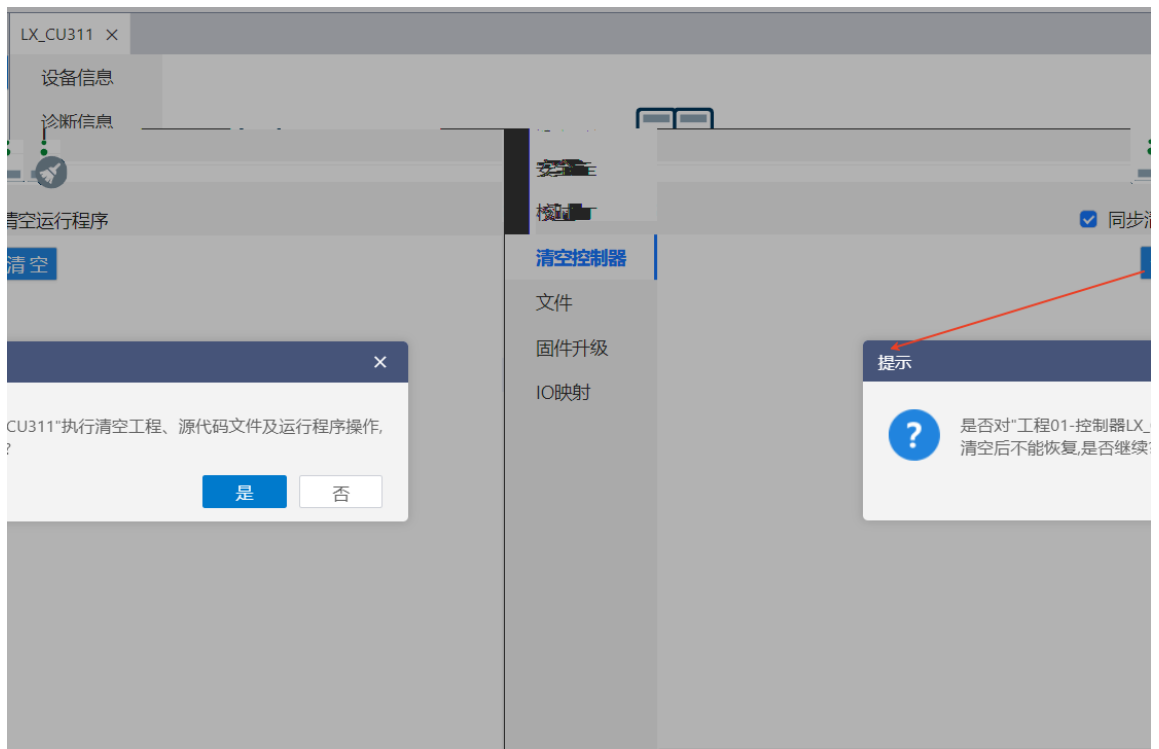

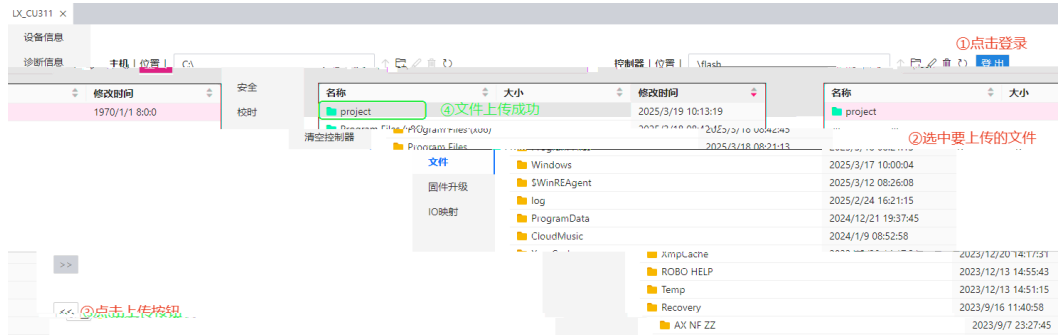

信息输出 x 问题

- 【2025-03-19 10:13:19】 工程01-控制器LX_CU311 用户文件操作：上传文件"/flash/project/"成功
- 【2025-03-19 10:19:41】 工程01-控制器LX_CU311 用户文件操作：登出成功
- 【2025-03-19 10:19:43】 工程01-控制器LX_CU311 用户文件操作：登录成功
- 【2025-03-19 10:19:51】 工程01-控制器LX_CU311 用户文件操作：上传文件"/flash/project/"成功

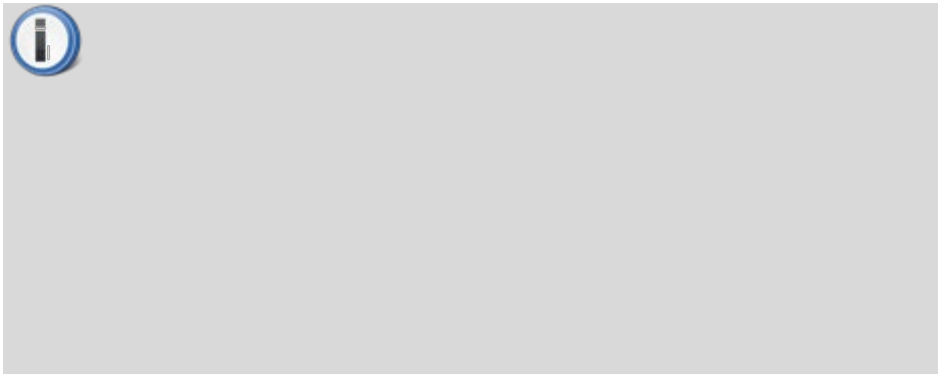

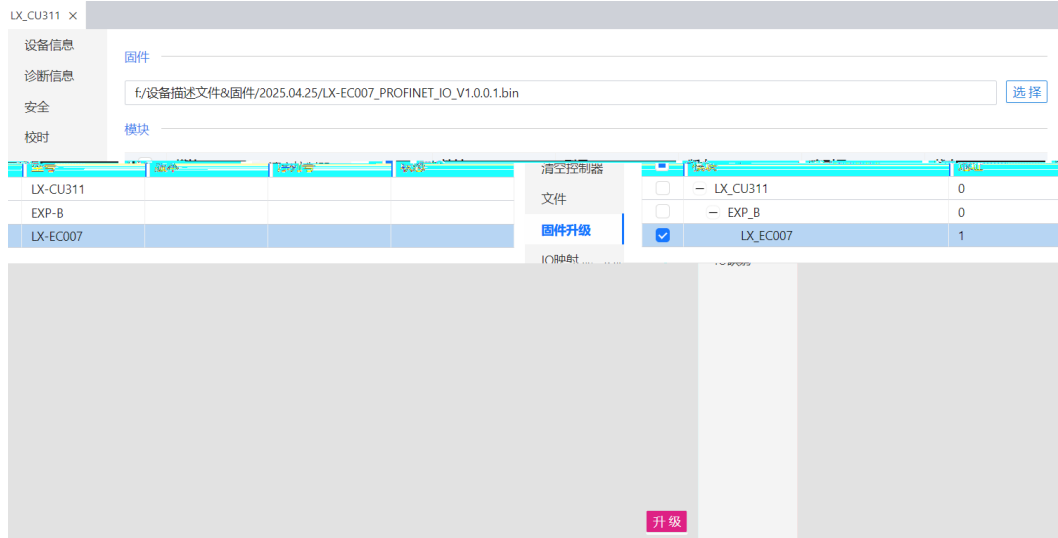

IO

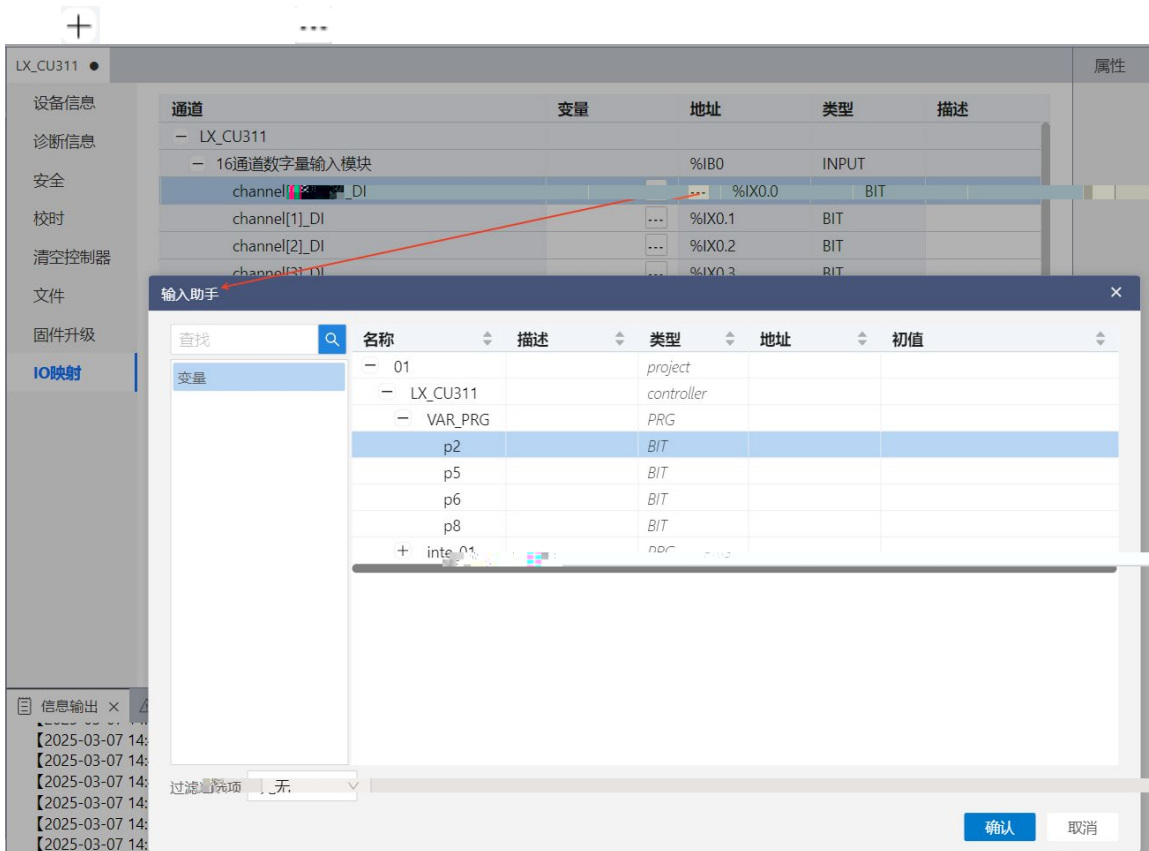

6.3

6.3.1

		LX-CU311		

6.3.2 LX-EC001 1 RS-232

6.3.2.1

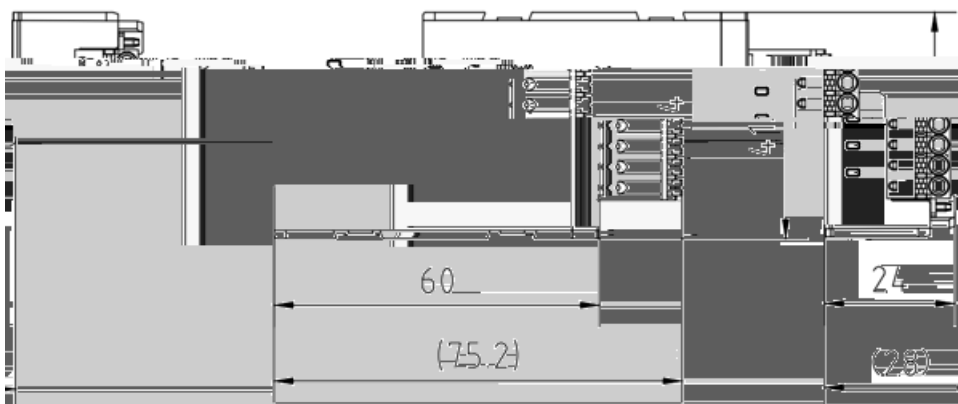

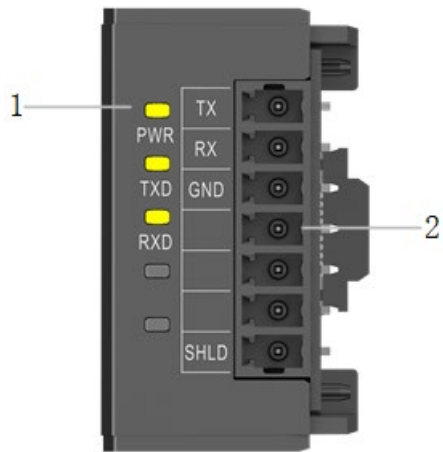



LED			



6.3.2.4

6.3.2.4.1

6.3.2.4.2 COM

COM

6.3.2.4.3 Modbus

Modbus-Master

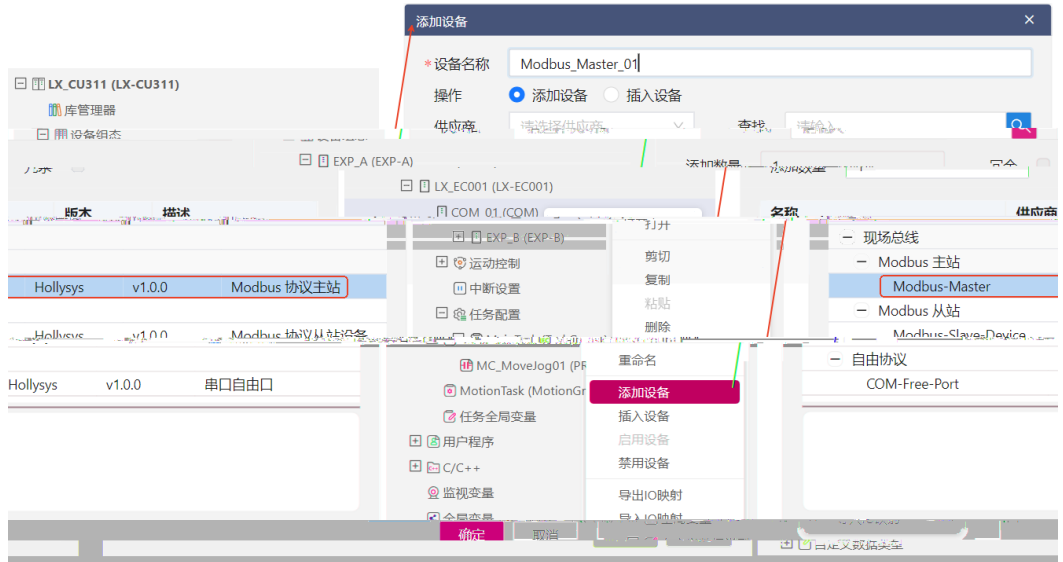

Modbus-Master

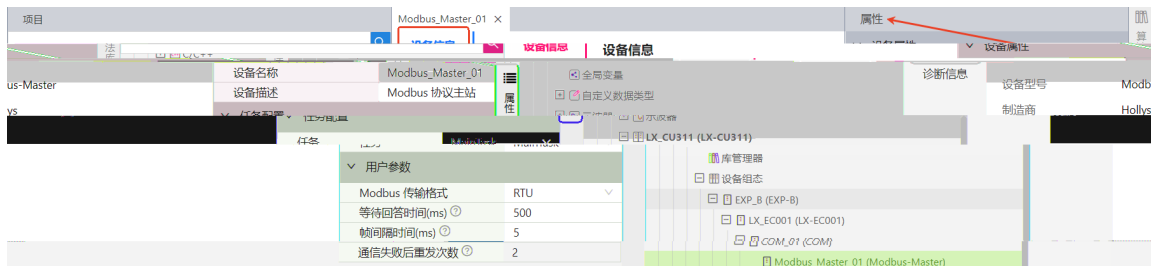





--	--



Modbus_Slave_01 ×

设备信息 + 回 ↑ ↓

诊断信息

模块信息

IO映射

序号	名称	访问类型	读偏移	读长度	写偏移	写长度
1	channel0	读离散量输入(1xxxx,02H)	0	1	0	0
2	channel1	写离散量输出(2xxxx,05H)	0	0	0	0
3	channel2	读保持寄存器(4xxxx,03H)	0	1	0	0
4	channel3	读保持寄存器(4xxxx,03H)	0	1	0	0
5	channel4	读离散量输入(1xxxx,02H)	0	1	0	0

属性

模块配置

用户参数

- Modbus 从站地址...
- Modbus 读写起始...
- Modbus 读写模拟...

Modbus_Slave_01 ×

设备信息

诊断信息

模块信息

IO映射

通道	变量	Modbus 地址	地址	类型	描述
+ channel0			%IB4	INPUT	
+ channel1			%QB4	OUTPUT	
+ channel2			%IW4	INPUT	
+ channel3			%IW6	INPUT	
+ channel4			%IB16	INPUT	
+ channel5			%QW4	OUTPUT	

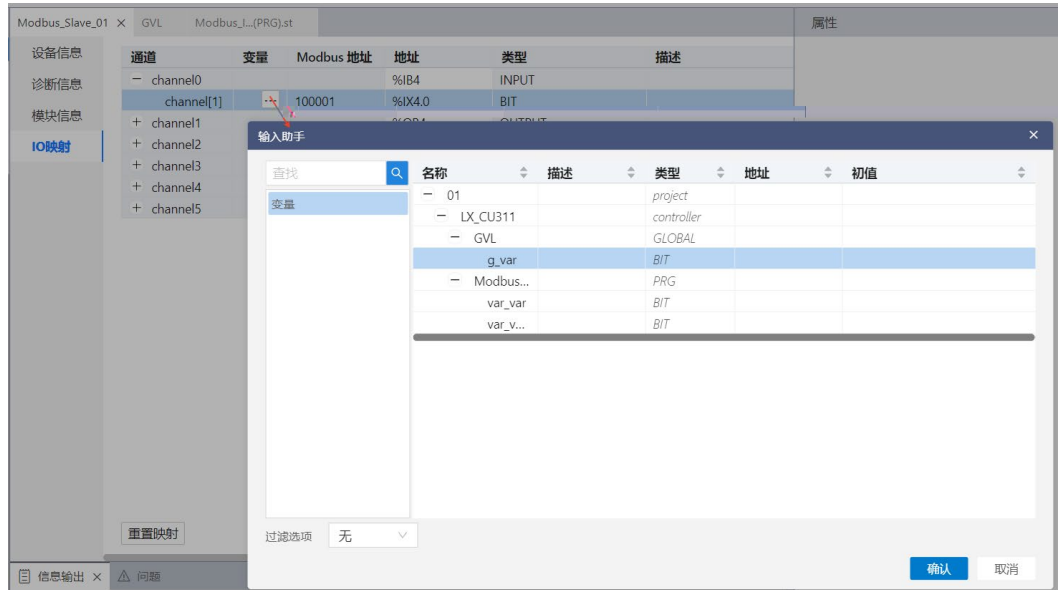

6.3.2.4.4 Modbus

Modbus_Slave_Device

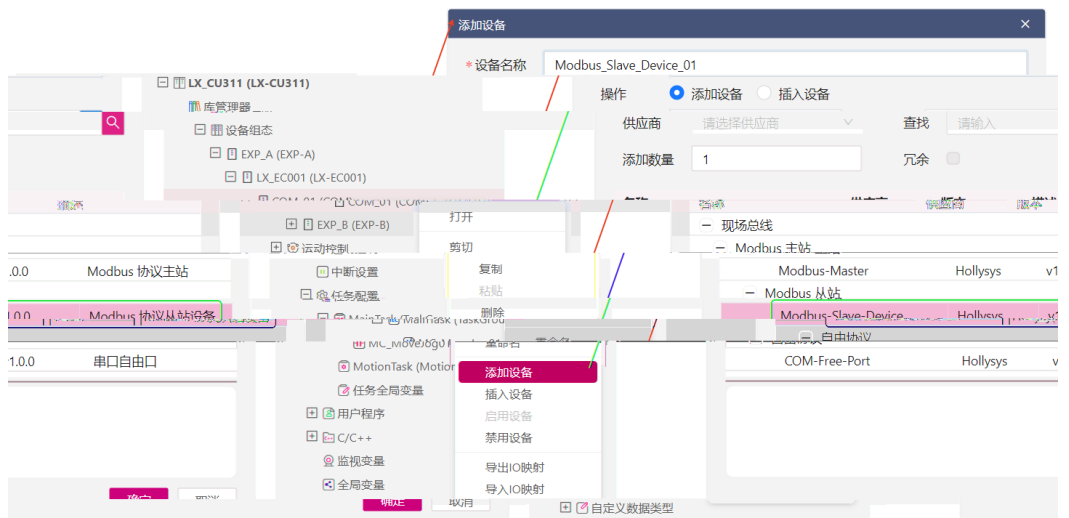

Modbus_Slave_Device

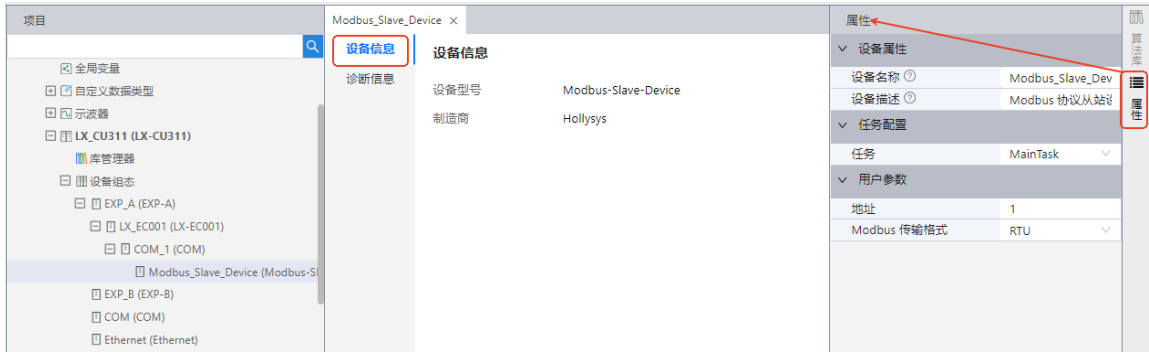

6.3.2.4.5

COM-Free-Port

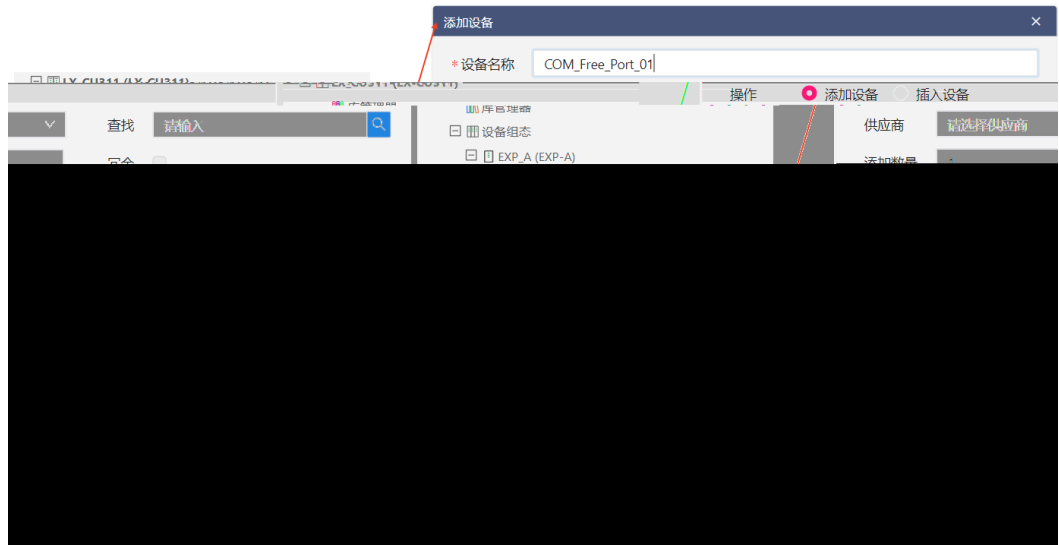

COM_Free_Port

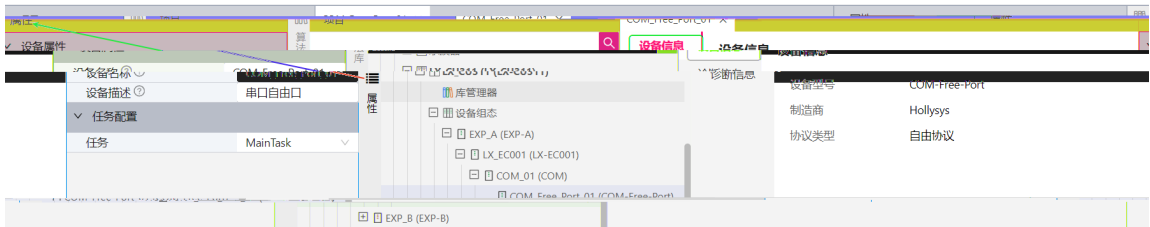

6.3.3 LX-EC002 1 RS-485

6.3.3.1

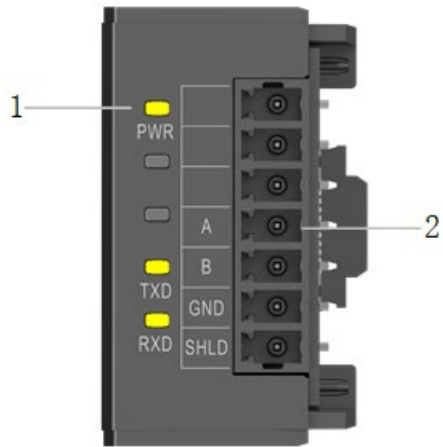
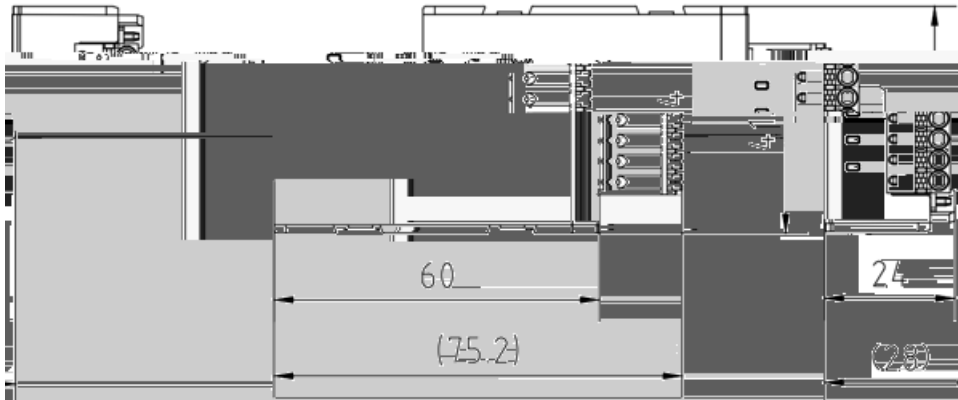

6.3.3.2

6.3.3.3

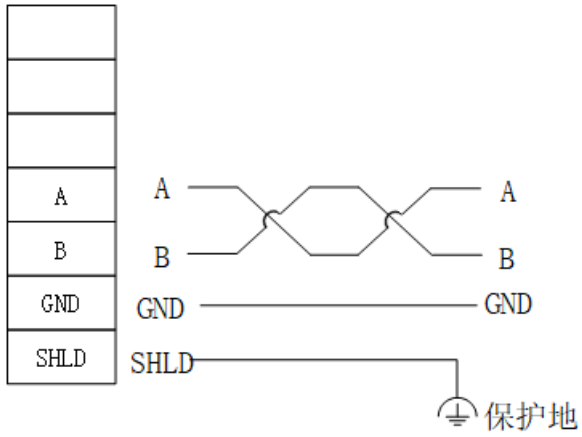



6.3.3.4

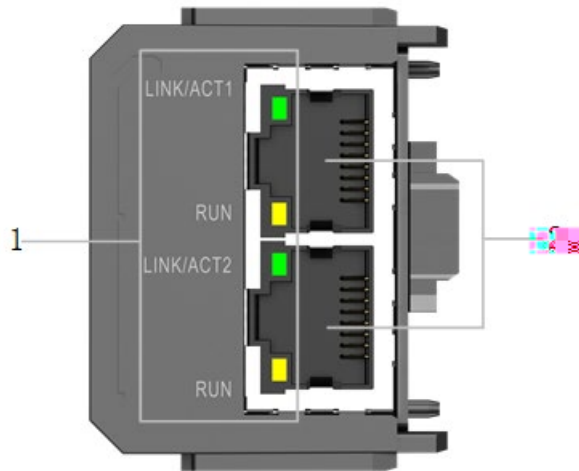
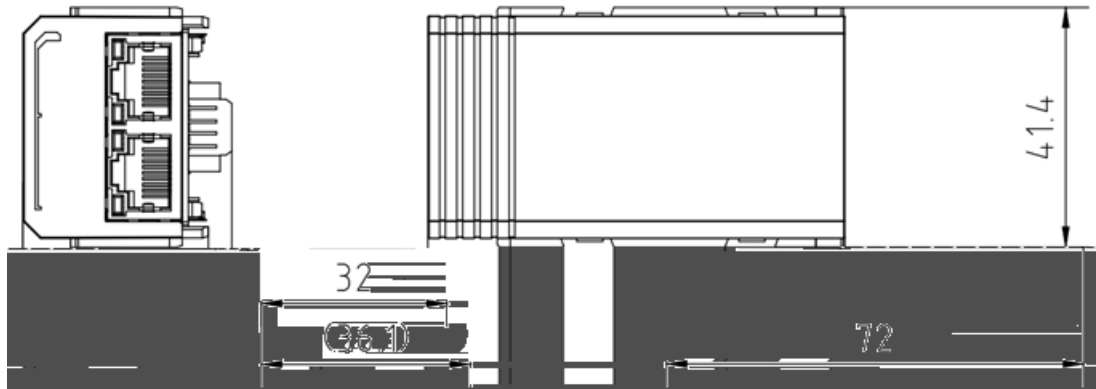

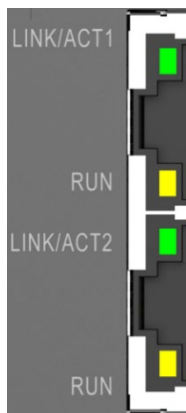

6.3.4.3

+
🗑️

LX_EC007 ×

设备信息

诊断信息

传输区设置

+
🗑️

序号	传输区	地址	数据区	长度	启用PROFenergy通信
📁					
无数据					

LX_EC007 ×

设备信息

诊断信息

传输区设置

+
🗑️

序号	传输区	地址	数据区	长度	启用PROFenergy通信
1	receive_01	%IB200	I区	16	否
2	send_01	%QB108	Q区	16	否

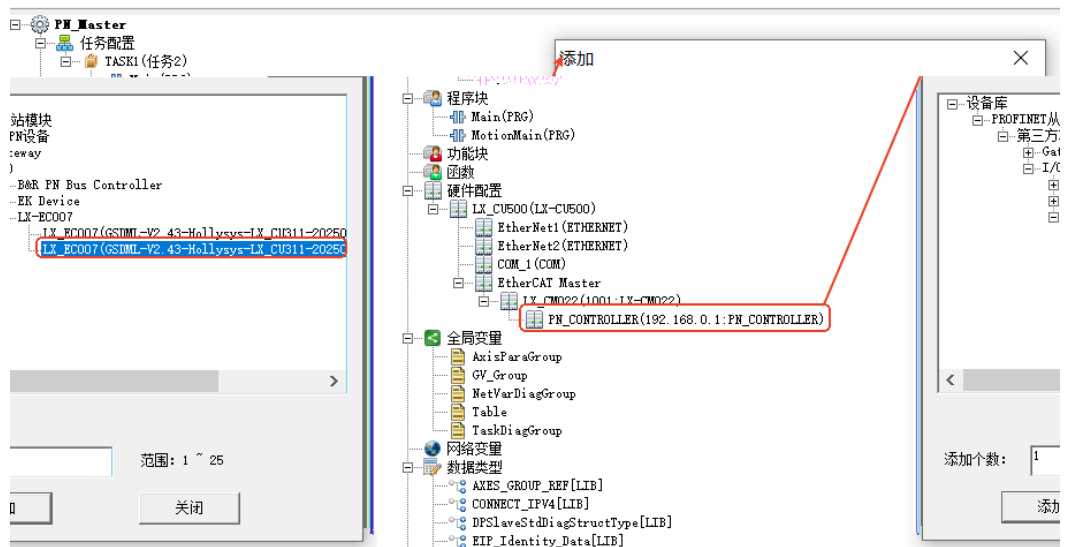

序号	传输区	地址	数据区	长度	启用PROFInergy通信
1	receive_01	%B200	I区	16	否
2	send_01	%QB108	Q区	16	否

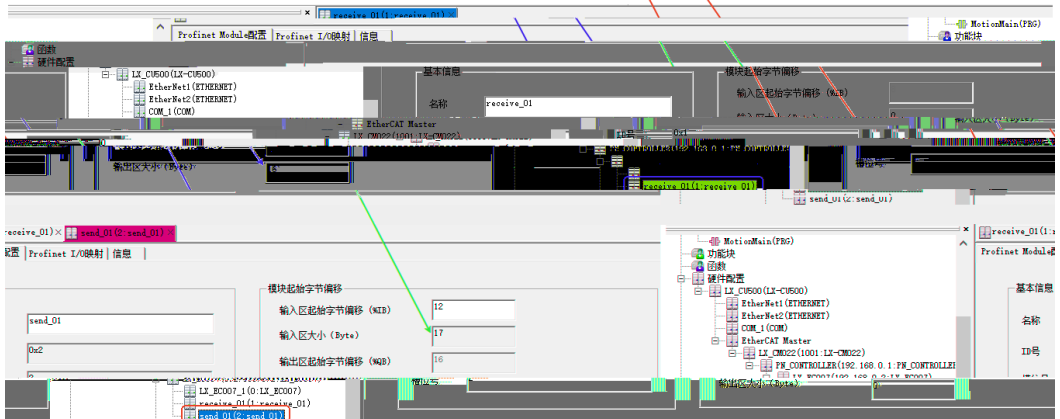

6.3.5 LX-EC021 2

1

6.3.5.1

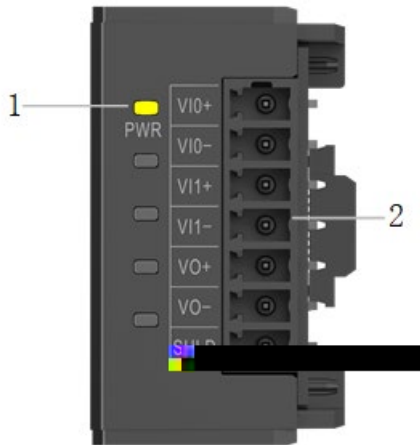
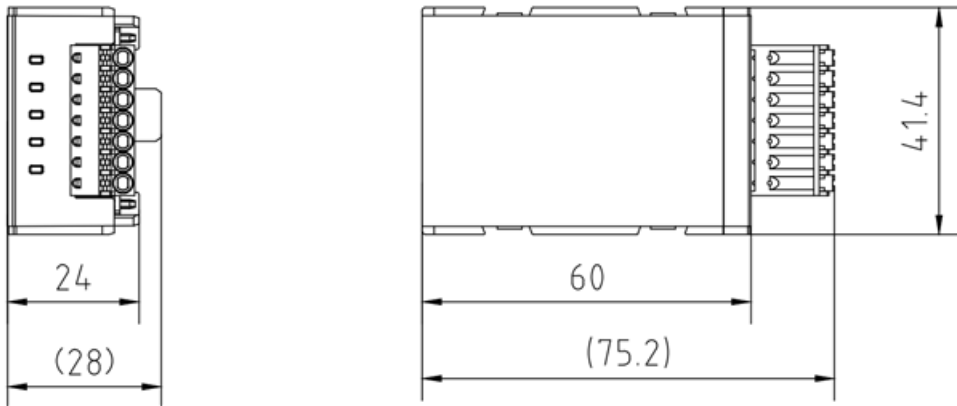



LX_EC021 X

设备信息 + - ↑ ↓

诊断信息

地址	名称	类型	描述
32	0		1 2AI模拟量输入模块
0	16	IO映射	2 1AO模拟量输出模块

IO

LX_EC021 X

设备信息	通道	变量	地址	类型	描述
%IW52	INPUT			诊断信息	- 2AI模拟量输入模块
...	%IW52	WORD		模块信息	+ channel[1]_AI
...	%IW53	WORD			+ channel[2]_AI
%QW18	OUTPUT			IO映射	- 1AO模拟量输出模块
...	%QW18	WORD			+ channel[1]_AO

+ ...

6.3.6 LX-EC032 RTC

6.3.6.1



6.4

6.4.1 LT-eEP02

6.4.1.1

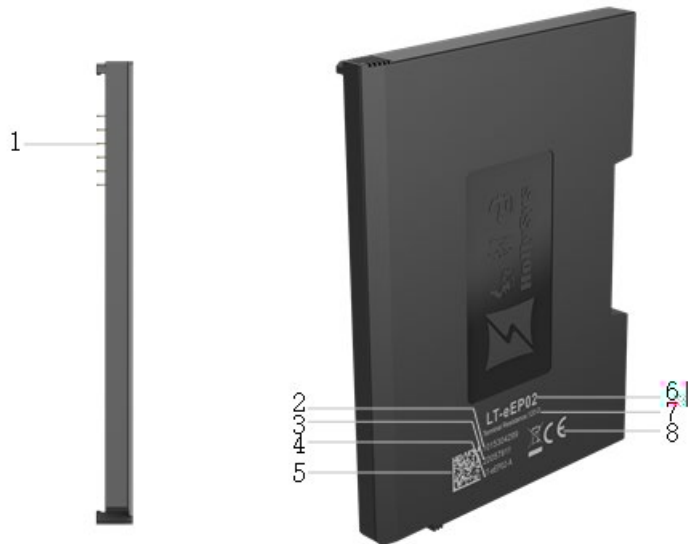

6.4.1.2

7

7.1

7.1.1

7.1.2



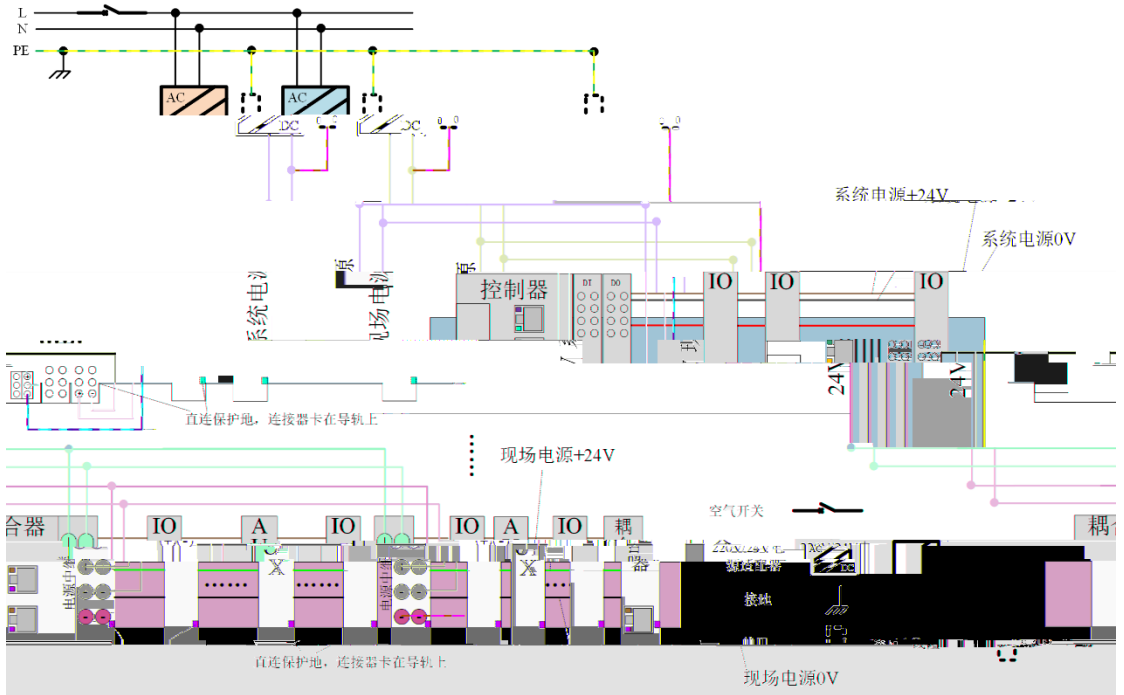

7.1.3

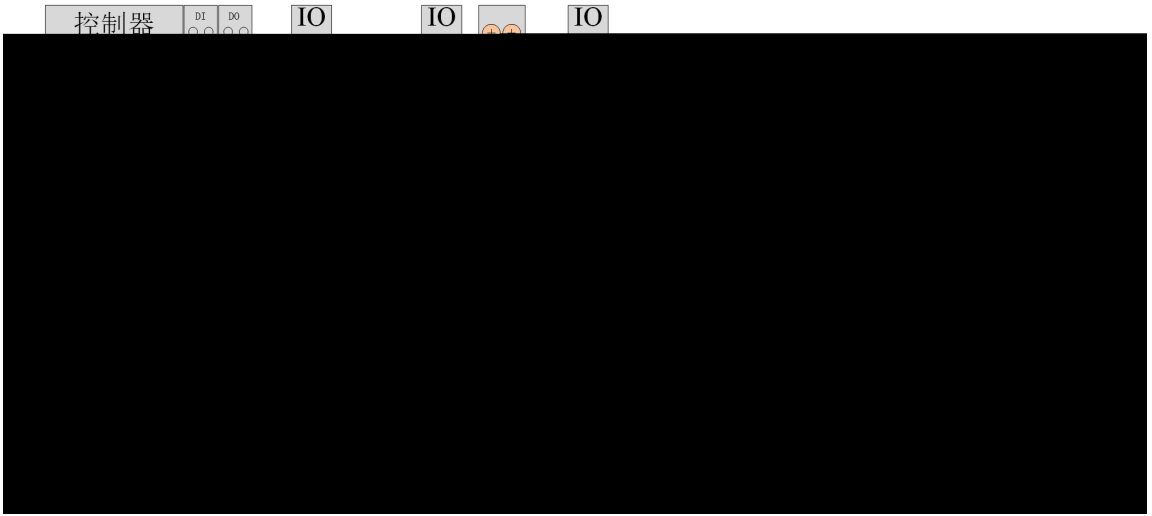

7.1.4

垂直方向安装1

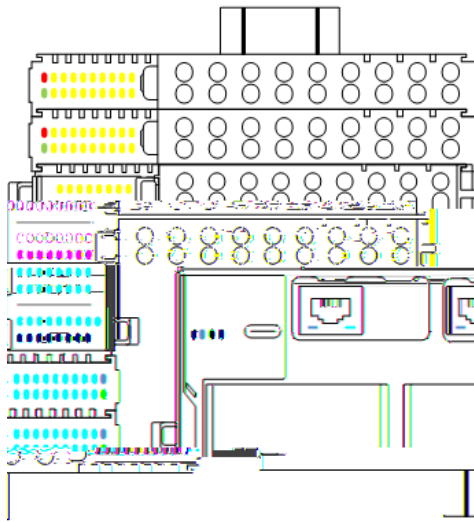

垂直方向安装2

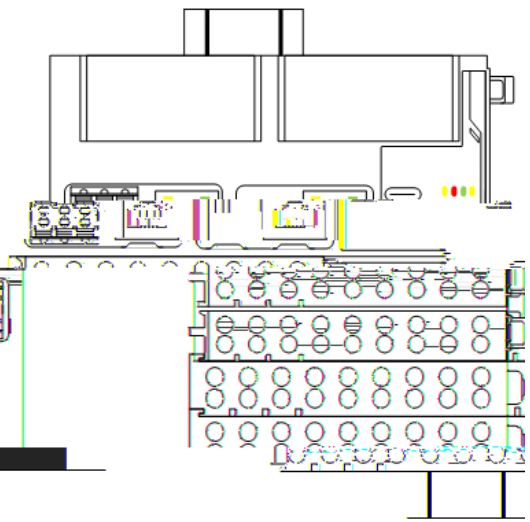

柜安装

电柜顶部安装

电柜底部

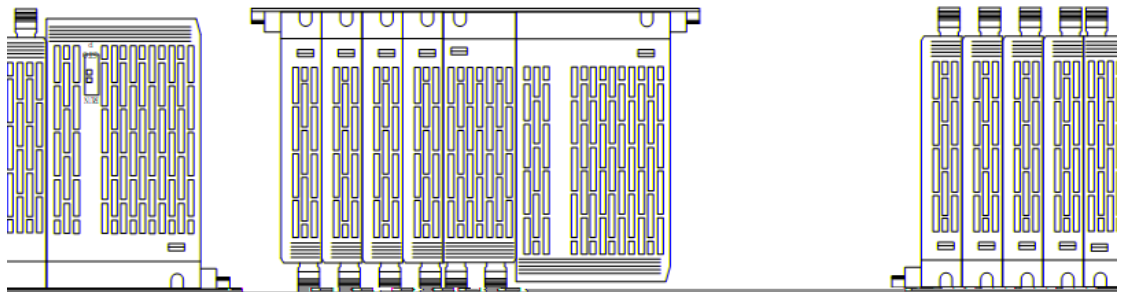

7.1.5

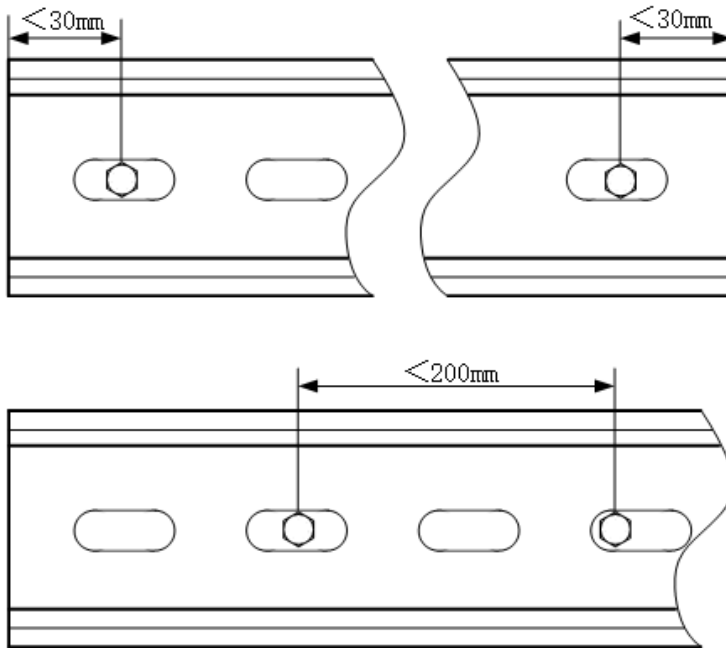
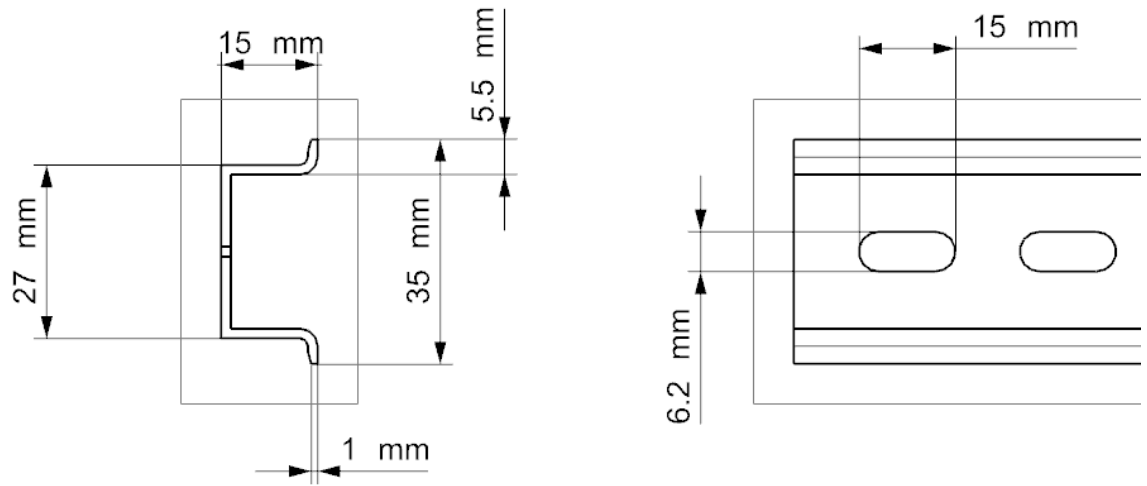

7.2

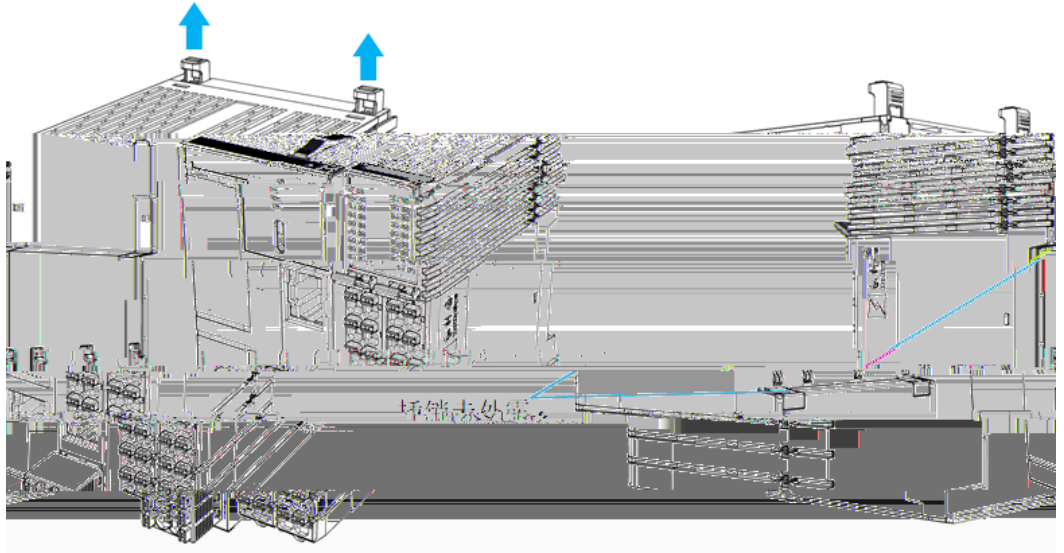

7.3

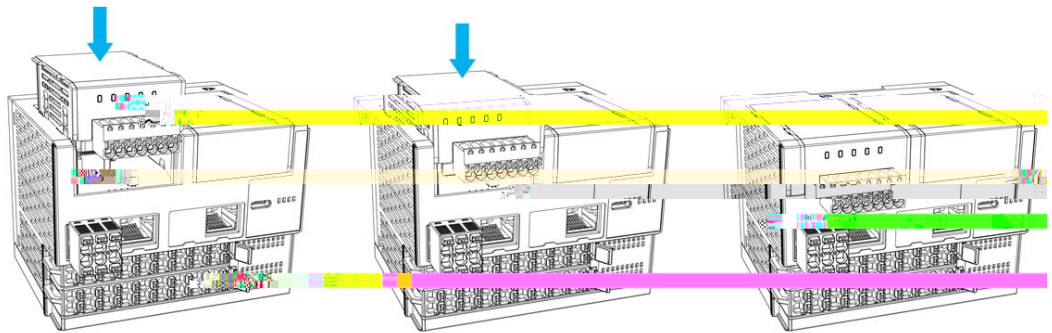

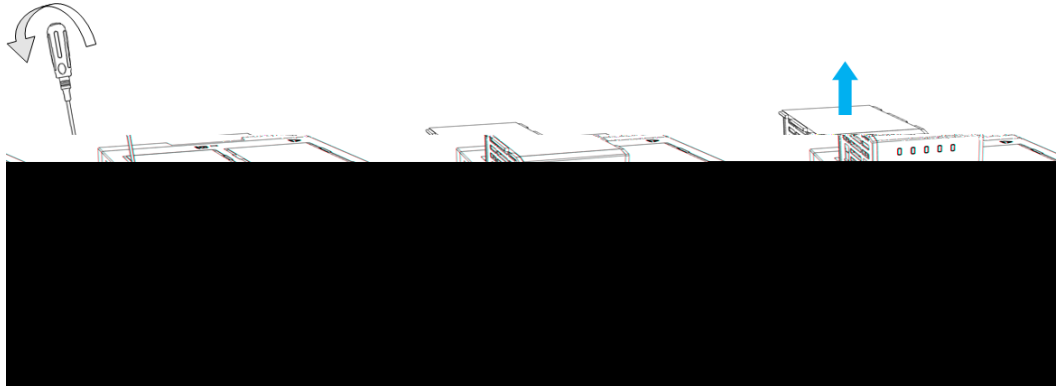

7.4 IO

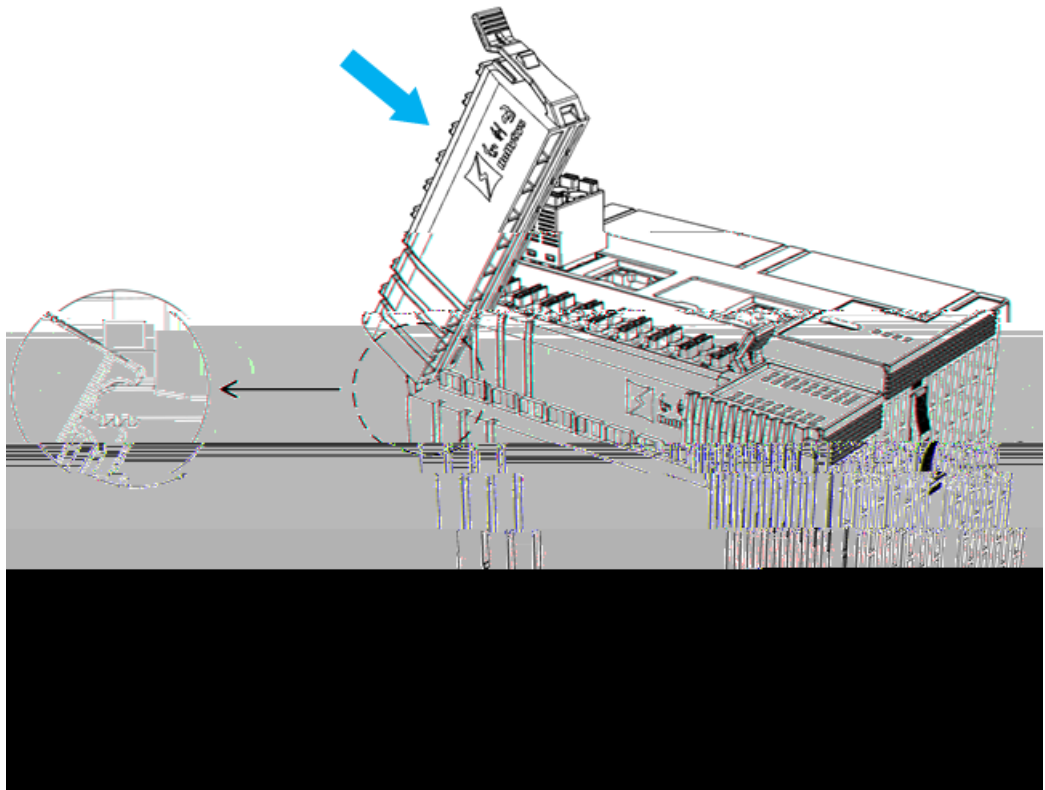

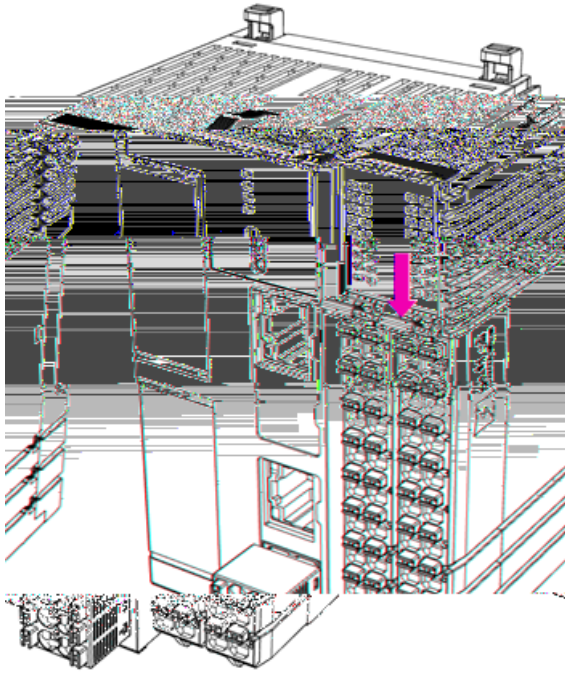

7.5

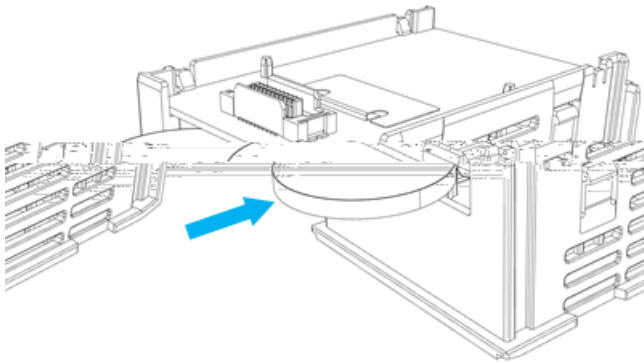

用手指捏住
拉舌

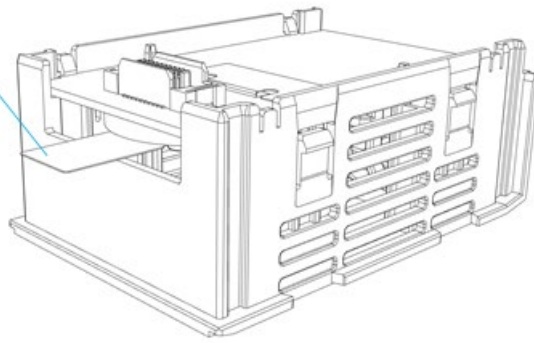

8

8.1

xx

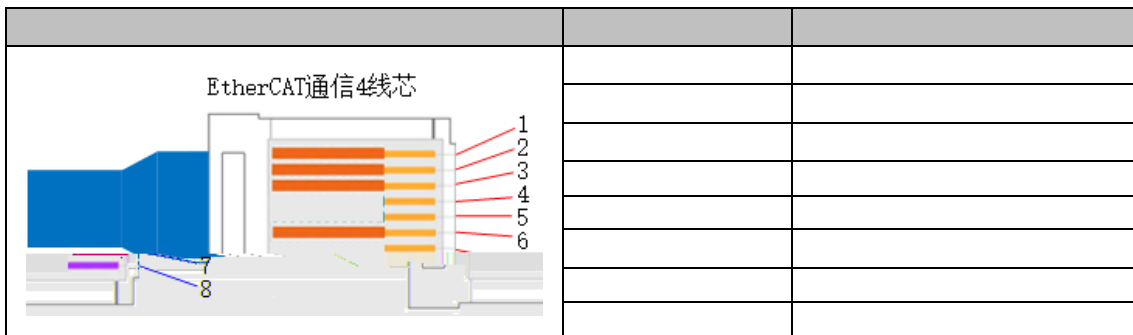
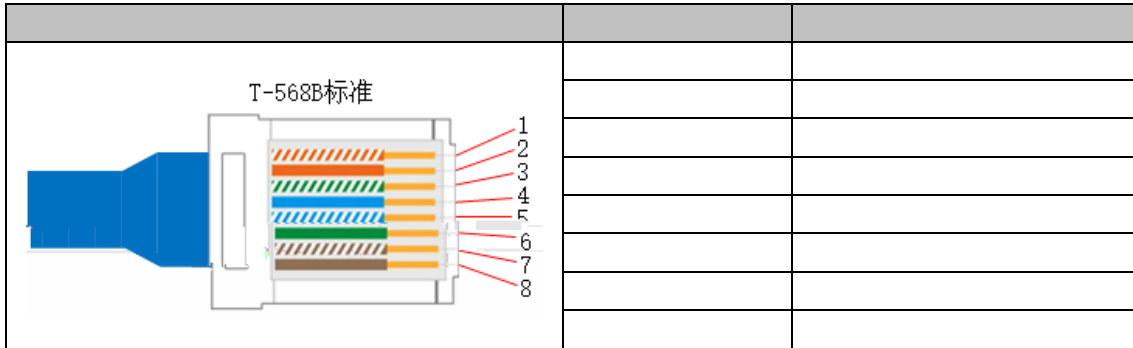

8.2

9

9.1

9.2

新建工程 - 基本信息 ×

PLC工程

算法库工程

项目 ▼

* 项目名称

项目描述

* 工程名称

工程描述

为工程设置密码

下一步 取消

新建工程 - 基本信息

⚠ 请为读权限和写权限设置不同的用户名，用户名或密码丢失后无法找回，请妥善保管!

读权限账户密码设置

* 用户名

* 密码

* 确认密码

读写权限账户密码设置

* 用户名

* 密码

* 确认密码

上一步 下一步 取消

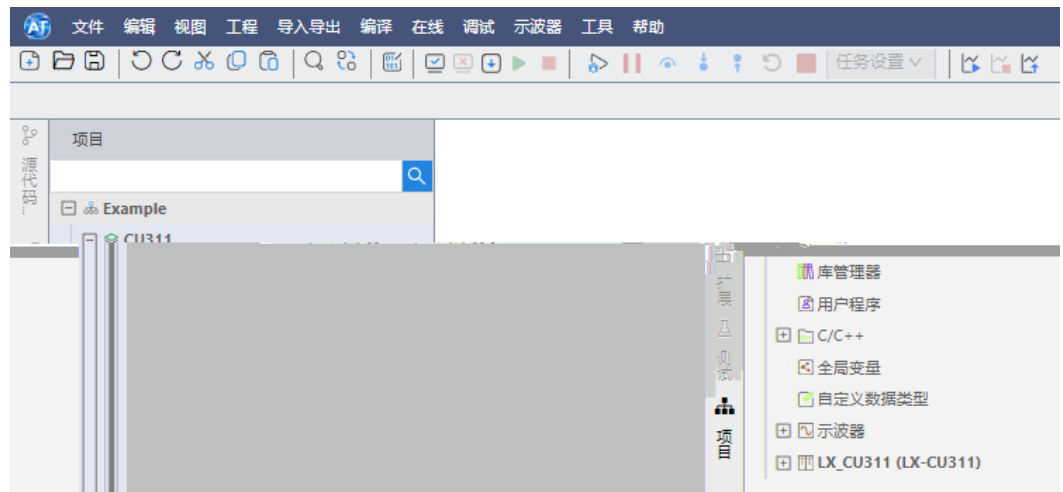

10.2 /

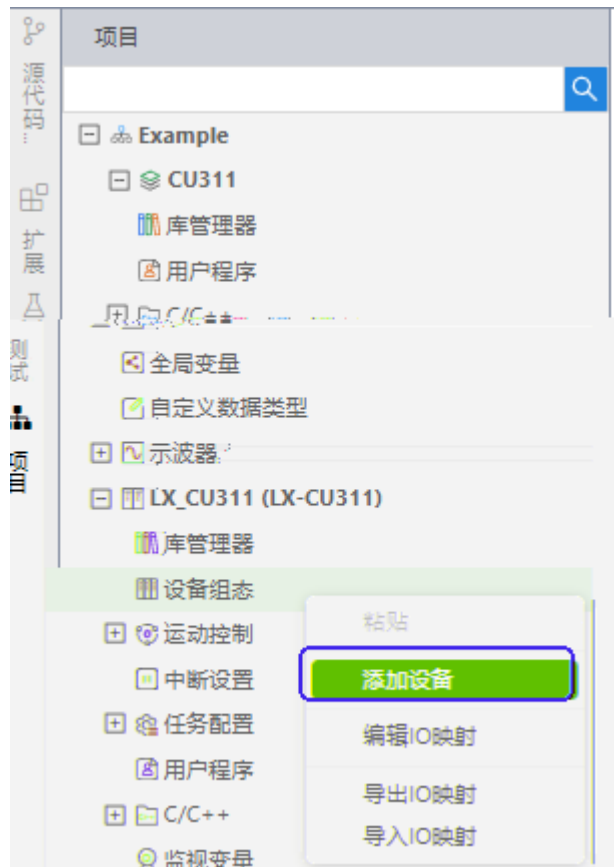

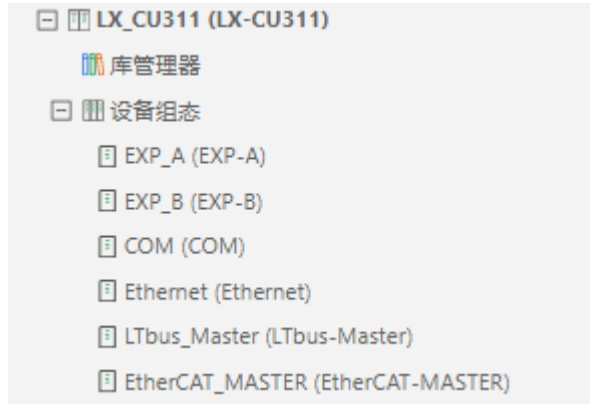
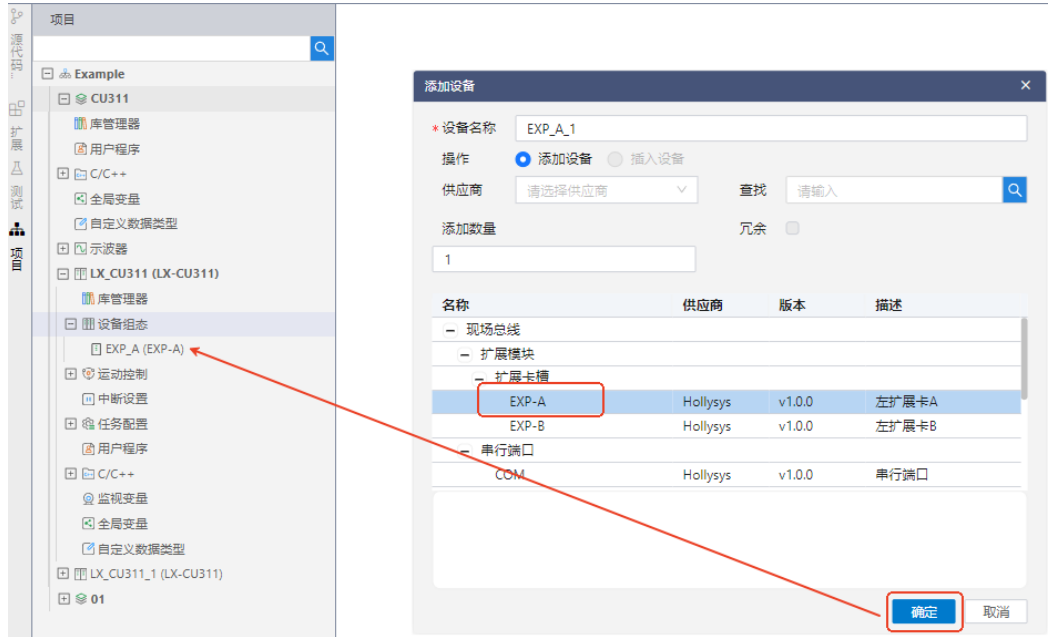

-
-
-
-
-

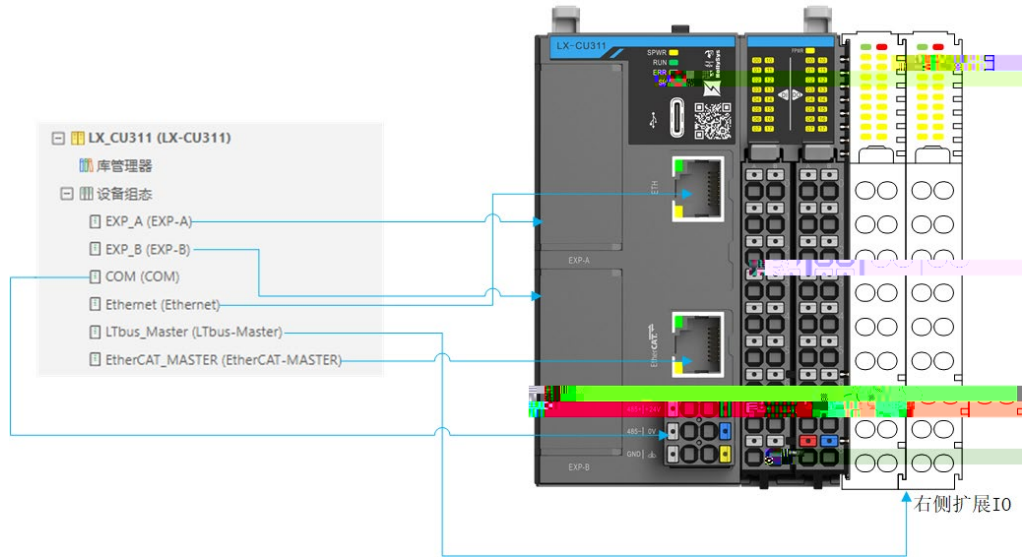

10.3

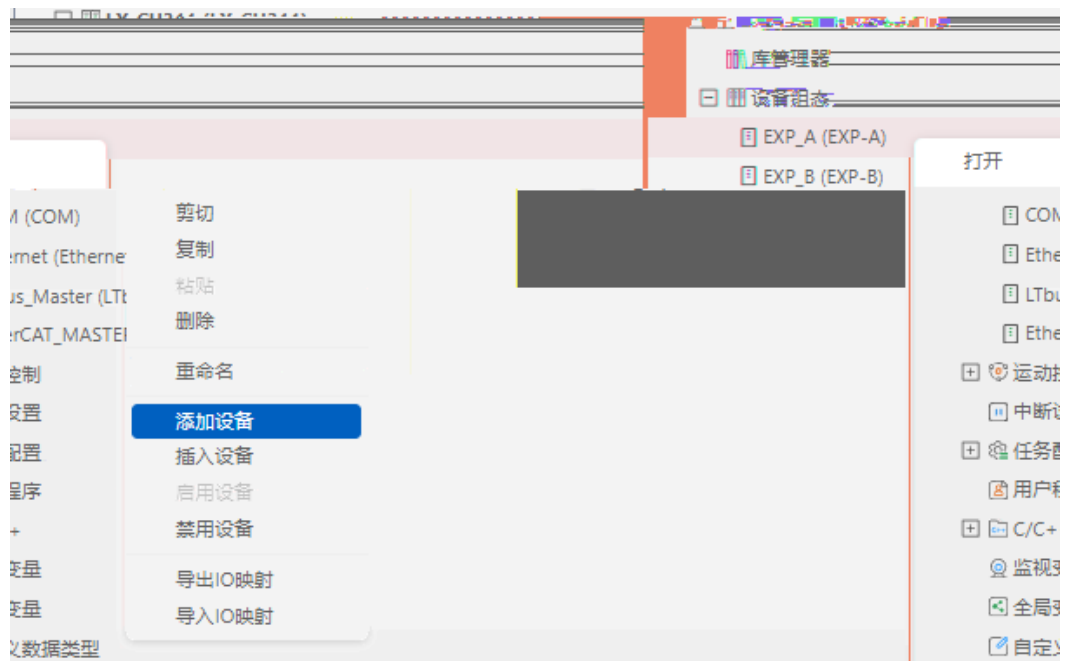

添加设备
✕

*设备名称

操作 添加设备 插入设备

冗余

添加数量

供应商	版本	描述	名称
EtherCAT			
EtherCAT 从站			
HollySys	LT-eIM01	#x00000001	EtherCAT耦合器模块
HollySys	LX-IM001	#x00000001	EtherCAT耦合器模块
HollySys	LX-IM002	#x00000001	EtherCAT末端耦合器...
HollySys	LX-AI001	#x00000001	4通道电压型模拟量...

设备全名 LT-eIM01(EtherCAT Coupler)

产品概述 LT系列的EtherCAT通信耦合器模块，IN口连接上一级EtherCAT网络，OUT口可连接下一级EtherCAT网络。接入系统和现场总线后，右侧可挂接10个模块。

+

LT_eIM01 X

② 单击

设备信息

诊断信息

EtherCAT

Modules

过程数据

启动参数

IO映射

序号	名称	标识	Module
1	terminals		
2	Terminals		
3	Terminals		
4	Terminals		
5	Terminals		
6	Terminals		
7	Terminals		
8	Terminals		
9	Terminals		
10	Terminals		
11	Terminals		
12	Terminals		
13	Terminals		
14	Terminals		
15	Terminals		
16	Terminals		
17	Terminals		
18	Terminals		
19	Terminals		

添加 Modules

名称	Module
- Analog Input Module	
- Analog Output Module	LT-eAI01(4 channels AI module...
- Digital Input Module	LT-eAO01(4 channels AO modu...
- Digital Output Module	LT-eDI01(16 channels NPN DI 2...
	LT-eDI02(16 channels PNP DI 2...
	LT-eDO01(16 channels NPN D...
	LT-eDO02(16 channels PNP DO...
	LT-eDO04(8 channels Relay DO...

③ 选择要添加的模块

④ 单击“确定”

11

11.1

DI

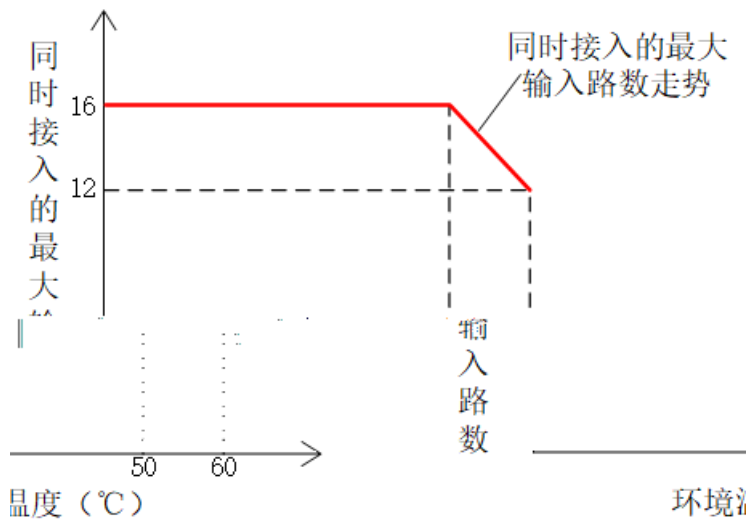

DO

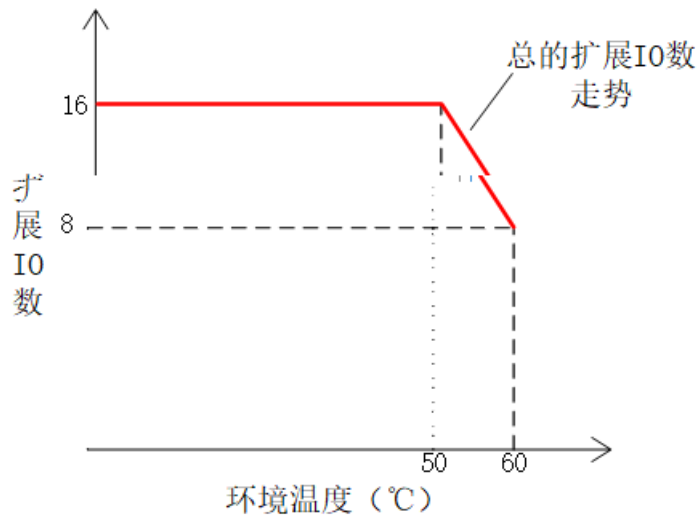
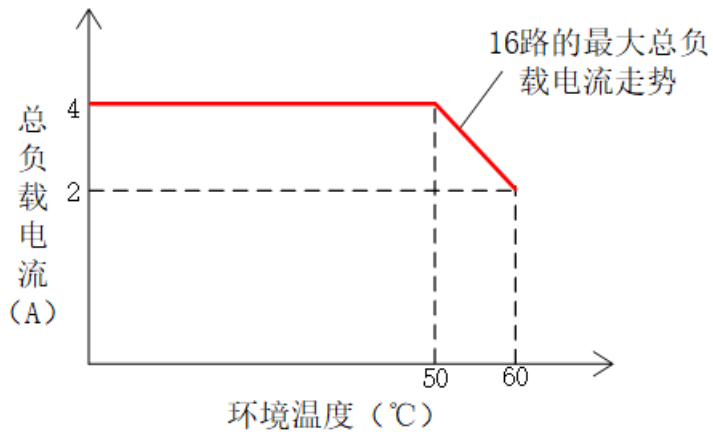

12

12.1

PLC

12.2

I/O

